

Eaton®
Quick Disconnect Couplings



Eaton Quick Disconnect Couplings – Customizing Solutions for the Future... Hydraulics and Beyond

For over 50 years, Eaton has continued to manufacture and supply the highest performing quick disconnect couplings globally for many different market segments including agriculture, construction, transportation, and fire and rescue just to name a few. Eaton's quality and performance have never been compromised when it comes to engineering and manufacturing its full line of quick disconnect couplings. From traditional industry standards to custom couplings for the next generation of emerging markets and new advanced technologies, Eaton continues to provide quick disconnect coupling solutions to meet your demands.

Custom Design Capability – One Application at a Time

Eaton continues the tradition of developing custom quick disconnect couplings for customers that need a product to perform above and beyond industry standards. Whether it is a custom coupling for the world's most powerful and sophisticated super computers that use electronic cooling or a self contained breathing apparatus coupling for first responders, Eaton has the ability to work directly with you on a solution. Contact Eaton to see how our dedicated and experienced design engineering team will work with you to develop a quick disconnect coupling solution.

Expanding the Product Line

The FD31, FD83, FD89-2000, FD96 and FD99 series quick disconnect coupling product lines provide Eaton customers with high performing fluid power solutions for traditional applications in the agriculture, construction, industrial and on-highway markets while expanding into new markets with customized solutions. The expanded line of quick disconnect couplings provide application solutions for electronic cooling and thermal management, off-shore and land based oil exploration, pharmaceutical, marine, chemical processing, hydraulic jack, portable ram, and mining applications. Most of the aforementioned couplings exhibit increased pressures and more extensive fluid compatibility options in order to operate in more complex applications. These couplings compliment our complete line of products that meet or exceed industry standards.



Table of Contents

| | |
|---|----|
| Custom Solutions | 2 |
| Overview | 4 |
| How to Order | 5 |
| Industry Applications | 6 |
| Safety Information | 7 |
| Fluid Compatibility | 8 |
| Fluid Transfer and Hydraulic | |
| FD35: 10,000 psi Arc Latch™ | 12 |
| FD45 (Steel): ISO 7241/1 Series B Interchange | 14 |
| FD45 (Brass): ISO 7241/1 Series B Interchange | 17 |
| FD45 (Stainless Steel): ISO 7241/1 Series B Interchange | 20 |
| FD48: Parker Bruning SM-250 Interchange | 23 |
| FD49: NFPA Standard T3.20.15 HTMA Interchange | 24 |
| 5100: Thread to Connect | 26 |
| 5600: ISO 7241/1 Series A Interchange | 30 |
| FD86: Thread to Connect 5,000 psi Dry Break – High Impulse | 35 |
| FD89: ISO 16028 Interchange | 37 |
| FD89 - 2000: 316 Stainless Steel ISO 16028 Interchange | 40 |
| FD96: High Pressure Thread to Connect Flush Face (Connect under Pressure) | 42 |
| FD99: High Pressure Flush Face ISO 16028 Interchange | 44 |
| Hydraulic Farm | |
| FD72: Connect Under Pressure – Farm ISO 5675 Interchange | 47 |
| FD70 & 76: Male Tip – Farm ISO 5675 Interchange | 48 |
| Diagnostics | |
| FD15: Oil Sampling Valve | 49 |
| FD90: Diagnostic Coupling SAEJ1502 | 51 |
| Pressure Gauge Kit: FF14802 | 53 |
| Special Applications | |
| FD14: Oil Drain Coupling | 55 |
| FD31: Enerpac Interchange | 58 |
| FD69: 10,000 psi Water Blast | 59 |
| FD83: Full Flow Dual Interlock | 61 |
| Refrigerant | |
| 5400: Low Air Inclusion Refrigerant | 62 |
| Air Couplings | |
| FD40: MIL-C-4109 Interchange | 67 |
| FD41: ARO 210 Interchange | 69 |
| FD43: MIL-C-4109 Interchange | 70 |
| Competitor Cross Reference | 72 |

Eaton® Quick Disconnect Couplings

Eaton Quick Disconnect Couplings are available in numerous configurations to meet all of your application needs. Eaton Quick Disconnects are available in traditional fluid power applications while expanding into new sustainable next generation markets. Increased pressures, fluid compatibility options and improved performance highlight the Eaton Quick Disconnect Coupling product line.

Markets

- Transportation
- Utility
- Food and Beverage
- Chemical Processing
- Marine
- Hydraulics
- Pharmaceuticals/Medical
- Electronics
- Oil and Gas
- Mining
- Industrial Plants
- Construction
- Agriculture
- Forestry
- Marine and Defense

Applications

- Hydraulic Jack
- Portable Hydraulic Rams
- Electronic Liquid Based Cooling
- Thermal Management Systems
- Industrial Fluid Transfer
- Hydraulic Fluid Transfer
- Chemical Processing
- Pharmaceutical Transfer
- Oil Field
- Agricultural Equipment
- High Impulse Hydraulics
- Chemical Transfer
- Construction Equipment



Off-Shore



Mining



Agriculture



Industry

How to Order

How to Order

Eaton Quick Disconnect Couplings can be ordered as separate halves. For special packaging, contact Eaton. Standard coupling part numbers are described below.

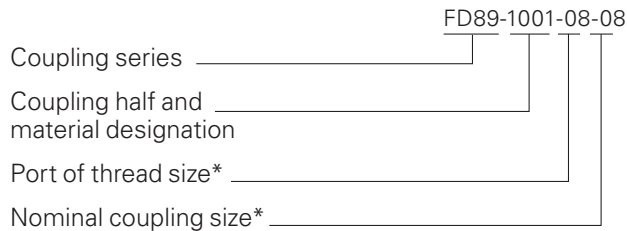

* Size designations are represented in 16ths of an inch, i.e., 06 = $\frac{6}{16}$ or $\frac{3}{8}$ inch

Dimensions

Dimensions in this catalog are for reference only. Actual dimensions may vary from those shown.

Coupling Identification

Generally, the coupling series or complete part number will be stenciled on the coupling body.

Caution:

The user should carefully observe the precautions listed in this catalog. These include selection of seals and body materials for fluid compatibility and recommendations on the selection of quick disconnect couplings. In addition, care should be taken not to exceed the maximum operating pressures listed for each coupling size and type shown in the physical characteristics table for each coupling. Because of possible variations in machining tolerances, quality control, inspection and quality assurance, Eaton coupling halves should not be used with coupling halves supplied by other manufacturers except where such use is approved for a particular coupling as noted in this catalog or specifically by Eaton.

For Technical Assistance Contact:

Eaton's Hydraulics Group
14615 Lone Oak Road
Eden Prairie, MN 55344

Phone: 952-937-9800

Fax: 952-974-7722

fpgproductsupport@eaton.com



Construction



Forestry

Industry Applications

Industry applications are provided for each coupling indicating where it is typically used.

Agriculture



FD14, FD42, FD48, 5400, 5600, FD70, FD72, FD76, FD89, FD90, FD96

Electronics Cooling



FD45 (stainless), FD45 (brass), 5100, 5400, FD83, FD89-2000 (stainless)

Marine and Military



FD14, FD15, FD35, FD45 (stainless), FD45 (brass), 5100, 5400, 5600, FD69, FD86, FD90, FD89, FD89-2000 (stainless), FD99, FD96

Pharmaceutical/Medical



FD15, FD45 (brass), FD45 (stainless), 5400, FD83, FD89-2000 (stainless)

Chemical Transfer



FD45, FD49, 5100, 5400, FD45 (stainless), FD83, FD89-2000 (stainless)

Food and Beverage



FD15, FD45 (stainless), FD89-2000 (stainless)

Industrial Plants/Processing



FD14, FD31, FD35, FD40, FD41, FD43, FD45 (steel), FD45 (brass), FD45 (stainless), FD48, FD49, 5100, 5600, FD69, FD86, FD89, FD89-2000 (stainless), FD96, FD99

Construction/Mining



FD14, FD15, FD35, FD40, FD41, FD42, FD43, FD45 (steel), FD48, FD49, 5100, 5400, 5600, FD69, FD86, FD89, FD90, FD96, FD99

Forestry



FD14, FD15, 5600, FD86, FD89, FD96, FD99

Transportation



FD14, FD15, FD42, FD45 (steel), FD45 (brass), 5100, 5400, 5600, FD90, FD96, FD89-2000 (stainless)

Oil and Gas (Offshore/Oil Patch)



FD15, FD35, FD45 (stainless), FD45 (brass), 5100, 5600, FD86, FD90, FD89, FD89-2000 (stainless)

Maintenance/Repair Operations



FD14, FD31, FD40, FD41, FD43, FD45 (steel), FD45 (brass), FD49, 5100, 5600, FD69, FD89, FD96

Utility/Aerial Life/Material Handling



FD14, FD15, FD35, FD45 (steel), FD49, 5100, FD86, FD89, FD90, FD96, FD99

Safety Information for Eaton Quick Disconnect Couplings

1.0 General Instructions.

- 1.1 Scope.** The scope of this safety bulletin is to warn against improper selection, use, installation, etc. of Eaton coupling products.
- 1.2 Distribution.** A copy of this safety bulletin should be distributed to all individuals responsible for using and/or selecting Eaton coupling products.
- 1.3 Fail-Safe.** Design all systems and equipment for fail-safe operation such that failure of any component does not result in personal injury and/or property damage.
- 1.4 User Responsibility.** It is the sole responsibility of the user to select and determine that the Eaton product is compatible with the end use application. The user is responsible for reading and following this safety bulletin as well as any instructions or literature on the Eaton product being used. The user must provide necessary product warnings for Eaton couplings products, used with systems or equipment, to the operators of the systems or equipment.
- 1.5 Usage with other Manufacturers' Products.** When using Eaton coupling products with other manufacturers' adapters, hoses, etc., do not exceed the lowest pressure rating of any of the components being used or rupture may result.

2.0 Selection of Eaton Couplings.

- 2.1 Pressure.** Ensure that the maximum operating pressure of the system or equipment does not exceed the rated operating pressure of the Eaton coupling product or rupture may result.
- 2.2 Fluid Compatibility.** Verify that all components (seals, metals, etc.) are compatible with the fluid being conveyed. Failure to do so may result in high speed fluid discharge and/or leakage of fluids which may be flammable, toxic, at extreme temperatures, or otherwise harmful.
- 2.3 Temperature.** Ensure that the maximum operating temperature of the system or equipment does not exceed the rated operating temperature of the Eaton coupling product (including seals) or rupture may result.
- 2.4 Coupling Size.** Use properly sized couplings such that there is not a large pressure drop across them thus avoiding system damage due to excessive heat generation or failure of internal components.
- 2.5 Sleeve Lock.** Use sleeve locks or threaded couplings where there is the possibility of accidental disconnection. Failure to utilize sleeve locks or threaded couplings in these applications may result in hose whip, expelled components, high speed fluid discharge, system damage, or leakage of fluids which may be flammable, toxic, at extreme temperatures, or otherwise harmful.

2.6 Connect or Disconnect Under Pressure.

If connection and/or disconnection of couplings under pressure is a requirement, only use couplings designed for connection/disconnection under pressure. Failure to utilize this type of coupling in that application may result in hose whip, expelled components, high speed fluid discharge, and/or system damage. Be certain not to confuse the rated operating pressure with the rated connect/disconnect under pressure.

- 2.7 Environment.** Ensure that Eaton couplings are compatible with the surrounding environment. The surrounding environment may be heat, salt water, moisture, chemicals, and the like. Failure to protect against an adverse environment may cause system damage, premature failure, and/or leakage of fluids which may be flammable, toxic, at extreme temperatures, or otherwise harmful.
 - 2.8 External Loads.** Avoid any external loads such as side loads, tensile loads, vibration, etc. Failure to do so may result in accidental disconnection, premature failure, system damage, and/or leakage of fluids which may be flammable, toxic, at extreme temperatures, or otherwise harmful.
 - 2.9 Welding & Brazing.** Extreme heating of plated products above +450°F (+232°C) such as welding, brazing, baking, etc., where the plating is burned off, may result in the release of deadly gases.
- ## 3.0 Installation of Eaton Couplings.
- 3.1 Inspection of Product.** Prior to installation, ensure that the Eaton product meets all of the requirements of the system and/or equipment it is to be used on. Ensure you have the correct part number, function test the coupling by connecting it with a mating half. The function test should result in smooth, non-binding operation or premature failure may result.
 - 3.2 Cleanliness.** Use end caps and plugs to reduce the risk of system contamination or damage to critical sealing surfaces. Failure to do so may result in leakage of fluids which may be flammable, toxic, at extreme temperatures, or otherwise harmful. Caps and plugs are not a secondary seal unless explicitly noted.
 - 3.3 Location.** Place Eaton couplings in a safe location such as not to expose the user to personal injury (slippage, tripping, falling, etc.) during installation, connection, disconnection and maintenance.
 - 4.0 Product Maintenance.** A maintenance schedule should be put in place to ensure that Eaton couplings are functioning properly.
 - 4.1 Inspection.** Visually inspect to ensure that there is no leakage, cracked components, corrosion build-up, contamination build-up, wear, etc. If any abnormality is encountered, the coupling should be replaced immediately.

Fluid Compatibility

This chart indicates the suitability of various elastomers and metals for use with fluids to be conveyed. It is intended for use with Eaton couplings and should not be used to determine compatibility for other products. It is intended as a guide only and is not a guarantee. Final selection of the proper seal or material of metal components is further dependent on many factors including pressure, fluid and ambient temperature, concentration, duration of exposure, etc.

How to Use the Chart

- Both the elastomer and the metal must be considered when determining suitability of combination for a coupling.
- Locate the fluid to be conveyed and determine the suitability of the elastomeric and metal components according to the resistance rating shown for each.
- Dimensional and operation specifications for each coupling can be found on the catalog pages.
- Information on seal options for couplings, and how to specify them, are shown in the respective sections of this catalog.
- Be sure to check the table below for maximum operating temperature range of the elastomer desired.
- For further details on the products shown in this catalog, and their applications, consult your Eaton Sales Representative or Eaton Technical Support.
- Coupling component materials may differ from body material. Refer to specific catalog pages.

Seal Elastomer Data*

| Seal Elastomer | Application Specification | Max. Operation Temperature Range |
|---------------------------------|---------------------------|--------------------------------------|
| Buna-N | none | -40°F to +250°F (-40°C to +121°C) |
| Neoprene | none | -65°F to +212°F (-54°C to +100°C) |
| EPR (Ethylene Propylene Rubber) | none | -65°C to +300°F (-54°C to +149°C) |
| Viton | MIL-R-25897 | -15°F to +400°F (-29°C to +204°C) |

*For reference only, based on Eaton recommended temperatures
Contact Eaton technical support for further information.

Resistance Rating Key

E = Excellent – Fluid has little or no effect

G = Good – Fluid has minor to moderate effect

C = Conditional – Service conditions should be described to Eaton for determination of suitability for application

U = Unsatisfactory

The differences between ratings “E” and “G” are relative. Both indicate satisfactory service. Where there is a choice, the materials rated “E” may be expected to give better or longer service than those rated “G”

This charts below are intended for reference use only. The information in this chart pertains strictly to material compatibility and is not intended to be used as an application guide.

E=Excellent
G=Good
C=Conditional
U=Unsatisfactory

| Fluid | Seals | | | | Metal | | | |
|---------------------------|--------|----------|----------|-------|-------|-------|-----------------|----------|
| | Buna-N | Neoprene | EPR/EPDM | Viton | Steel | Brass | Stainless Steel | Aluminum |
| Acetaldehyde | U | C | C | U | G | E | E | E |
| Acetic Acid, 10% | U | U | E | G | U | U | C | C |
| Acetic Acid, Glacial | U | U | C | U | U | U | C | C |
| Acetone | U | U | G | U | E | E | E | E |
| Acetophenone | U | U | E | U | E | E | E | C |
| Acetyl Acetone | U | U | G | U | U | C | C | C |
| Acetyl Chloride | U | U | U | E | C | C | C | U |
| Acetylene (1) | G | U | G | E | E | E | E | E |
| Air, Hot (Up to +160°F) | E | E | E | E | E | E | E | E |
| Air, Hot (161°F – 200°F) | C | G | E | E | E | E | E | E |
| Air, Hot (201°F – 300°F) | U | U | G | E | E | E | E | E |
| Air Wet, below 160°F | E | E | E | E | U | G | E | E |
| Aluminum Chloride, 10% aq | E | E | E | E | U | U | U | U |
| Aluminum Fluoride, 10% aq | E | E | E | E | U | U | U | E |
| Aluminum Nitrate, 10% aq | E | E | E | E | U | U | C | C |

| Fluid | Seals | | | | Metal | | | |
|----------------------------------|--------|----------|----------|-------|-------|-------|-----------------|----------|
| | Buna-N | Neoprene | EPR/EPDM | Viton | Steel | Brass | Stainless Steel | Aluminum |
| Aluminum Sulfate, 10% aq | E | E | E | E | U | C | E | C |
| Alums, 10% aq | E | E | E | E | U | C | E | C |
| Ammonia, Cold | E | E | E | U | E | U | E | E |
| Ammonia, Hot | U | G | G | U | E | U | E | E |
| Ammonia, Anhydrous | G | G | E | U | E | U | E | E |
| Ammonia, Aqueous | E | E | E | U | E | U | E | E |
| Ammonium Carbonate, 10% aq | U | E | E | U | C | U | C | C |
| Ammonium Chloride, 10% aq | E | E | E | U | U | U | C | U |
| Ammonium Hydroxide, 10% aq | C | C | E | C | G | U | C | C |
| Ammonium Nitrate, 10% aq | E | G | E | U | G | U | G | G |
| Ammonium Phosphate, 10% aq | E | E | E | - | U | C | G | U |
| Ammonium Sulfate/Sulfide, 10% aq | E | E | E | U | U | U | G | U |
| Amyl Acetate | U | U | G | U | E | E | E | E |
| Amyl Alcohol | G | C | E | G | G | G | E | U |
| Aniline, Aniline Oil | U | U | G | U | E | U | E | G |

Fluid Compatibility

E=Excellent
G=Good
C=Conditional
U=Unsatisfactory

| Fluid | Seals | | | | Metal | | | |
|------------------------------|--------|----------|----------|-------|-------|-------|-----------------|----------|
| | Buna-N | Neoprene | EPR/EPDM | Viton | Steel | Brass | Stainless Steel | Aluminum |
| Aniline Dyes | U | G | G | G | U | C | G | C |
| Asphalt, < 200°F | G | C | U | E | E | G | E | C |
| IRM 901 Oil | E | E | C | E | E | E | E | E |
| IRM 902 Oil | E | G | U | E | E | E | E | E |
| IRM 903 Oil | E | C | U | E | E | E | E | E |
| Automatic Trans. Fluid | E | C | U | E | E | E | E | E |
| Barium Chloride, 10% aq | E | E | E | E | U | G | G | G |
| Barium Hydroxide, 10% aq | E | E | E | E | G | U | G | U |
| Barium Sulfide, 10% aq | E | E | E | E | C | U | G | U |
| Benzene, Benzol | U | U | U | E | G | E | E | G |
| Benzoic Acid | U | U | U | E | U | G | G | G |
| Benzyl Alcohol | U | G | G | E | E | G | E | G |
| BioDiesel (<B20) | G | C | U | E | | | | |
| BioDiesel (>B20) | G | C | U | E | | | | |
| Black Sulfate Liquor | C | C | C | E | E | C | E | U |
| Blast Furnace Gas | U | U | U | E | E | C | E | U |
| Borax, 10% aq | G | G | E | E | E | E | E | G |
| Boric Acid, 10% aq | G | G | G | E | U | G | C | C |
| Brine | E | G | E | E | U | G | G | U |
| Bromine, Dry | U | U | U | E | U | C | U | C |
| Butane | E | C | U | E | E | E | E | E |
| Butyl Acetate | U | U | G | U | E | E | E | E |
| Butyl Alcohol | E | E | G | E | G | G | G | G |
| Butyl Cellosolve | U | U | G | U | E | E | E | E |
| Butylene (Butene) | C | U | U | E | E | E | E | E |
| Butyl Stearate | G | U | U | E | G | G | G | G |
| Butyraldehyde | U | U | G | U | E | E | E | E |
| Calcium Acetate, 10% aq | G | G | E | U | G | G | G | C |
| Calcium Bisulfate, 10% aq | E | E | U | E | U | C | C | U |
| Calcium Chloride, 10% aq | E | E | E | E | G | G | G | C |
| Calcium Hydroxide, 10% aq | E | E | E | E | G | G | G | U |
| Calcium Hypochlorite, 10% aq | U | U | E | E | U | G | C | U |
| Calcium Nitrate, 10% aq | E | E | E | E | G | G | G | G |
| Carbitol | G | G | G | G | E | E | E | E |
| Carbolic Acid (Phenol) | U | U | G | E | U | E | E | - |
| Carbonic Acid | G | E | E | E | U | C | E | G |
| Carbon Dioxide, Dry Gas | G | G | E | E | E | E | E | E |
| Carbon Disulfide | U | U | U | E | G | G | G | E |
| Carbon Monoxide | G | G | E | E | E | E | E | E |
| Carbon Tetrachloride | U | U | U | E | U | G | G | U |
| Castor Oil | E | E | G | E | E | E | E | E |
| Cellosolve Acetate | U | U | G | U | U | U | E | G |
| China Wood Oil (Tung Oil) | G | G | U | E | E | G | E | E |
| Chlorine Gas, Dry | U | U | U | G | C | C | C | C |
| Chloroacetic Acid | U | U | G | U | U | U | U | U |
| Chloroacetone | U | U | E | U | G | G | G | U |
| Chlorobenzene | U | U | U | G | G | G | G | G |
| Chloroform | U | U | U | E | G | G | G | G |
| O-Chlorophenol | U | U | U | E | G | G | G | U |
| Chosulfonic Acid | U | U | U | U | G | U | G | G |
| Chrome Plating Solution | U | U | G | E | C | U | U | U |

| Fluid | Seals | | | | Metal | | | |
|---------------------------------|--------|----------|----------|-------|-------|-------|-----------------|----------|
| | Buna-N | Neoprene | EPR/EPDM | Viton | Steel | Brass | Stainless Steel | Aluminum |
| Chromic Acid | U | U | C | E | C | U | U | U |
| Citric Acid | E | E | E | E | C | C | C | C |
| Coke Oven Gas | U | U | U | E | E | C | E | U |
| Copper Chloride, 10% aq | E | E | E | E | U | U | U | U |
| Copper Cyanide, 10% aq | E | E | E | E | E | U | G | U |
| Copper Sulfate, 10% aq | E | E | E | E | U | C | G | U |
| Cotton Seed Oil | E | G | C | E | E | E | E | E |
| Creosote (Coal Tar) | G | C | U | E | E | C | E | E |
| Crude Oil | E | G | U | E | G | U | G | U |
| Cyclohexanol | E | G | U | E | E | E | E | C |
| Cyclohexanone | U | U | G | U | E | E | E | C |
| Detergent/Water Solution | E | E | E | E | G | E | E | E |
| Diacetone Alcohol (Acetol) | U | U | E | U | E | E | E | E |
| Dibenzyl Ether | U | U | G | U | G | G | G | G |
| Diesel Oil | E | C | U | E | E | E | E | E |
| Diethylamine | G | G | G | U | E | U | E | - |
| Diocetyl Phthalate (DOP) | U | U | G | G | E | E | E | E |
| DOT #3 / #4 Brake fluid | C | U | E | U | E | C | E | E |
| Dowtherm A&E | U | U | U | E | G | U | E | E |
| Ethyl Alcohol (Ethanol) | E | E | E | E | E | E | E | G |
| Ethyl Acetate | U | U | G | U | E | E | E | E |
| Ethyl Benzene | U | U | U | E | E | G | G | G |
| Ethyl Cellulose | G | G | G | U | E | G | G | G |
| Ethyl Chloride | U | U | U | E | E | E | E | G |
| Ethylene Dichloride | U | U | U | G | G | C | G | G |
| Ethylene Glycol | E | E | E | E | U | G | E | E |
| Ferric Chloride, 10% aq | E | G | E | E | U | U | U | U |
| Ferric Nitrate, 10% aq | E | E | E | E | U | U | G | U |
| Ferric Sulfate, 10% aq | G | G | G | E | U | U | E | U |
| Formaldehyde | C | C | G | G | E | E | E | G |
| Formic Acid | C | G | E | U | U | C | C | C |
| Fuel Oil | E | C | U | E | E | E | E | E |
| Furfural | C | C | G | U | G | G | G | G |
| Gallic Acid, Solution | G | G | G | E | U | - | G | C |
| Gasoline | E | U | U | E | E | E | E | E |
| Gasohol | G | U | U | E | E | E | E | G |
| Glycerine/Glycerol | E | E | E | E | E | G | E | E |
| Green Sulfate Liquor | G | G | E | E | U | U | E | U |
| Helium (1) | E | E | E | E | E | E | E | E |
| Heptane | E | G | U | E | E | E | E | E |
| Hexaldehyde | U | G | G | U | G | G | E | E |
| Hexane | E | G | U | E | E | E | E | E |
| Hydraulic Oils, petroleum based | G | C | U | E | E | E | E | E |
| Ester Blend | E | U | U | E | E | E | E | E |
| Phos. Ester/Petroleum Blend | U | U | U | C | E | E | E | E |
| Silicone Oils | E | E | E | E | E | E | E | E |
| Straight Petroleum Base | E | C | U | E | E | E | E | E |
| Straight Phosphate Ester | U | U | G | C | E | E | E | E |
| Water Glycol | E | E | E | E | E | E | E | G |
| Water Petroleum Emulsion | E | G | U | E | C | E | E | G |
| Hydrobromic Acid | U | U | E | E | E | U | E | E |

Fluid Compatibility

E=Excellent
G=Good
C=Conditional
U=Unsatisfactory

| Fluid | Seals | | | | Metal | | | |
|-----------------------------|--------|----------|----------|-------|-------|-------|-----------------|----------|
| | Buna-N | Neoprene | EPR/EPDM | Viton | Steel | Brass | Stainless Steel | Aluminum |
| Hydrochloric Acid, Cold | U | U | G | E | U | U | U | U |
| Hydrocyanic Acid | C | C | E | E | E | E | G | E |
| Hydrofluoric Acid | U | U | C | U | U | U | U | U |
| Hydrofluorosilic Acid | G | G | E | E | U | U | U | U |
| Hydrogen | E | E | E | E | E | E | E | E |
| Hydrogen Peroxide | G | G | G | E | U | U | G | E |
| Hydrogen Sulfide, Dry | U | G | E | U | E | G | G | G |
| Isocyanate | U | U | G | E | G | - | G | - |
| Iso Octane | E | G | U | E | E | E | E | E |
| Isopropyl Acetate | U | U | G | U | E | - | E | E |
| Isopropyl Alcohol | G | G | E | E | E | E | E | G |
| Isopropyl Ether | G | U | U | U | G | G | G | - |
| JP-4, JP-5 | E | U | U | E | E | E | E | E |
| Kerosene | E | U | U | E | E | E | E | E |
| Lacquer/Lacquer Solvents | U | U | U | U | U | E | E | E |
| Lime Sulfur | U | E | E | E | G | U | G | - |
| Linseed Oil | E | G | U | E | E | E | E | E |
| LPG | E | G | U | E | E | E | E | E |
| Magnesium Chloride, 10% aq | E | E | E | E | E | C | C | G |
| Magnesium Hydroxide, 10% aq | G | G | E | E | E | G | E | G |
| Magnesium Sulfate, 10% aq | E | E | E | E | E | E | E | E |
| Maleic Acid | U | U | U | E | E | G | G | G |
| Maleic Anhydride | U | U | U | E | G | U | E | G |
| Malic Acid | G | G | U | G | U | - | E | G |
| Mercuric Chloride | E | E | E | E | U | U | U | U |
| Mercury | E | E | E | E | E | U | E | U |
| Methanol | G | G | E | U | G | G | E | C |
| Methyl Bromide | G | U | U | E | E | E | G | U |
| Methyl Chloride | U | U | U | E | E | E | E | U |
| Methyl Butyl Ketone | U | U | E | U | E | E | E | - |
| Methyl Ethyl Ketone | U | U | E | U | G | G | G | G |
| Methylene Chloride | U | U | U | G | G | G | G | G |
| Methyl Isobutyl Ketone | U | U | U | U | G | G | G | G |
| Methyl Isopropyl Ketone | U | U | U | U | G | G | G | G |
| Methyl Salicylate | U | U | C | U | E | G | G | E |
| MIL-L-2104 | E | G | U | E | E | E | E | - |
| MIL-H-5606 | E | G | U | E | E | E | E | E |
| MIL-H-6083 | E | E | U | E | E | E | E | - |
| MIL-L-7808 | G | U | U | E | G | G | E | - |
| MIL-L-23699 | G | U | U | E | E | E | E | E |
| MIL-H-46170 | E | G | U | E | E | E | E | - |
| MIL-H-83282 | E | U | U | E | E | E | E | - |
| Mineral Oils | E | C | U | E | E | E | E | E |
| Naphtha | C | U | U | E | - | - | - | - |
| Naphthalene | U | U | U | E | E | G | E | G |
| Naphthenic Acid | C | U | U | E | - | G | E | G |
| Natural Gas | E | E | U | E | G | G | G | G |
| Nickel Acetate, 10% aq | C | C | E | G | G | C | E | G |
| Nickel Chloride, 10% aq | E | G | E | E | U | U | G | U |
| Nickel Sulfate, 10% aq | E | E | E | E | U | G | G | U |
| Nitric Acid, to 10% | U | U | U | E | U | U | E | U |

| Fluid | Seals | | | | Metal | | | |
|-------------------------------|--------|----------|----------|-------|-------|-------|-----------------|----------|
| | Buna-N | Neoprene | EPR/EPDM | Viton | Steel | Brass | Stainless Steel | Aluminum |
| Nitric Acid, over 10% | U | U | U | G | U | U | E | C |
| Nitrobenzene | U | U | U | G | E | G | E | E |
| Nitrogen | E | E | E | E | E | E | E | E |
| Octyl Alcohol | E | E | E | E | E | E | E | E |
| Oleic Acid | U | U | C | G | C | E | G | C |
| Oleum, fuming sulfuric acid | U | U | U | E | E | E | E | E |
| Ortho-Dichlorobenzene | U | U | U | E | G | G | G | G |
| Oxalic Acid, 10% aq | G | G | E | E | U | C | C | C |
| Oxygen | - | - | E | E | G | G | G | G |
| Palmitic Acid | E | G | G | E | G | - | E | G |
| Para-Dichlorobenzene | U | U | U | E | G | G | G | G |
| Pentane | E | E | U | E | G | G | G | E |
| Perchloric Acid | E | G | G | E | U | U | U | U |
| Perchloroethylene | U | U | U | E | C | G | G | G |
| Petroleum Base Oils | E | G | U | E | E | E | E | E |
| Phenol (Carbolic Acid) | U | U | G | E | U | E | E | E |
| Phosphate Ester | U | U | G | C | E | E | E | E |
| Phosphoric Acid 20% | U | U | G | E | U | E | U | C |
| Phosphorous Trichloride | U | U | E | E | C | U | C | E |
| Potassium Acetate, 10% aq | G | G | E | U | C | G | C | U |
| Potassium Chloride, 10% aq | E | E | E | E | E | C | E | U |
| Potassium Cyanide, 10% aq | E | E | E | E | C | U | G | U |
| Potassium Dichromate, 10% aq | E | E | E | E | C | C | C | C |
| Potassium Hydroxide, to 10% | G | G | E | G | G | G | G | U |
| Potassium Hydroxide, over 10% | C | C | E | U | G | G | G | U |
| Potassium Nitrate, 10% aq | E | E | E | E | G | G | E | G |
| Potassium Sulfate, 10% aq | E | E | E | E | - | - | - | - |
| Propane (Liquified) | C | G | - | E | E | E | E | E |
| Propyl Acetate | U | U | G | U | E | - | E | E |
| Propyl Alcohol | E | E | E | E | E | E | E | E |
| Propylene | U | U | U | E | E | E | E | E |
| Rapeseed oil (B100) | G | C | U | E | | | | |
| Refrigerant R-12 | G | E | C | E | E | E | E | E |
| Refrigerant R-13 | G | E | C | E | E | E | E | E |
| Refrigerant R-22 | U | E | C | U | E | E | E | E |
| Refrigerant R-134a | E | C | G | U | E | E | E | E |
| Sewage | E | E | E | E | G | G | G | G |
| Silicone Oils | E | E | E | E | E | E | E | E |
| Soap (Water Solutions) | E | E | E | E | E | E | E | U |
| Sodium Acetate, 10% aq | G | G | E | U | E | E | G | E |
| Sodium Bicarbonate, 10% aq | E | E | E | E | G | G | E | G |
| Sodium Borate, 10% aq | E | E | E | E | E | E | E | G |
| Sodium Carbonate, 10% aq | E | E | E | E | E | G | E | U |
| Sodium Chloride, 10% aq | E | E | E | E | U | C | C | C |
| Sodium Cyanide, 10% aq | E | E | E | E | E | - | C | U |
| Sodium Hydroxide, to 10% | U | G | E | E | C | G | C | U |
| Sodium Hydroxide, over 10% | U | U | G | E | C | C | C | U |
| Sodium Hypochlorite, 10% aq | C | C | E | C | U | U | U | U |
| Sodium Metaphosphate, 10% aq | E | E | E | E | E | G | G | U |
| Sodium Nitrate, 10% aq | G | G | E | - | E | C | E | E |
| Sodium Perborate, 10% aq | G | G | E | E | C | U | C | U |

Fluid Compatibility

E=Excellent
G=Good
C=Conditional
U=Unsatisfactory

| Fluid | Seals | | | | Metal | | | |
|----------------------------|--------|----------|----------|-------|-------|-------|-----------------|----------|
| | Buna-N | Neoprene | EPR/EPDM | Viton | Steel | Brass | Stainless Steel | Aluminum |
| Sodium Peroxide, 10% aq | G | G | E | E | U | U | C | C |
| Sodium Phosphates, 10% aq | E | E | E | E | U | E | G | U |
| Sodium Silicate, 10% aq | E | E | E | E | E | E | E | E |
| Sodium Sulfate, 10% aq | E | E | E | E | C | G | G | G |
| Sodium Sulfide, 10% aq | E | E | E | E | C | U | C | U |
| Sodium Thiosulfate, 10% aq | G | E | E | E | U | U | C | G |
| Soy Bean Oil (B100) | E | C | U | E | E | E | E | E |
| Stannic Chloride | E | G | E | E | U | U | U | U |
| Steam (up to 388°F) | U | U | C | C | E | E | E | G |
| Stearic Acid | G | G | G | E | C | C | E | C |
| Stoddard Solvent | E | G | U | E | E | E | E | E |
| Styrene | U | U | U | G | E | E | E | E |
| Sulfur, Slurry | U | E | E | E | E | U | G | E |
| Sulfur Chloride, Wet | U | U | U | E | G | - | G | G |
| Sulfur Dioxide, Dry | U | U | G | E | E | G | G | E |
| Sulfur Trioxide | U | U | G | E | G | C | G | G |
| Sulfuric Acid, to 10% | U | G | U | E | U | G | C | - |
| Sulfuric Acid, over 10% | U | U | U | G | C | C | C | U |
| Sulfurous Acid | C | C | U | G | U | C | C | C |
| Tannic Acid | G | E | E | E | E | E | E | C |

| Fluid | Seals | | | | Metal | | | |
|--------------------------|--------|----------|----------|-------|-------|-------|-----------------|----------|
| | Buna-N | Neoprene | EPR/EPDM | Viton | Steel | Brass | Stainless Steel | Aluminum |
| Tar (Bituminous) | G | U | U | E | E | G | E | E |
| Tartaric Acid | E | G | G | E | U | C | C | E |
| Tertiary Butyl Alcohol | G | G | G | E | G | G | G | G |
| Titanium Tetrachloride | C | U | U | E | E | U | G | U |
| Toluene (Toluol) | U | U | U | E | E | E | E | E |
| Trichlorethylene | U | U | U | E | E | G | E | E |
| Tricresyl Phosphate | U | U | E | G | E | - | C | - |
| Triethanolamine | E | U | E | U | E | U | E | E |
| Tung Oil | G | G | U | E | E | G | E | E |
| Turpentine | G | U | U | E | G | G | G | G |
| Varnish | G | U | U | E | E | G | E | E |
| Vinyl Chloride | U | U | U | E | E | U | C | E |
| Water (to +150°F) | E | E | E | E | C | G | E | G |
| Water (+151°F to +200°F) | E | E | E | E | C | G | E | G |
| Water (+201°F to +350°F) | U | U | G | G | C | G | E | G |
| Water Glycol | E | E | E | E | E | E | E | G |
| Water Petroleum Emulsion | E | G | U | E | C | E | E | G |
| Xylene | U | U | U | E | E | E | E | E |
| Zinc Chloride, 10% aq | E | E | E | E | E | U | U | C |
| Zinc Sulfate, 10% aq | E | E | E | E | U | C | G | C |

FD35 Series

10,000 psi Arc Latch™



The FD35 Series Arc Latch™ design has a greater surface contact area for long surface life in rugged high pressure applications. The maximum operating pressure is 10,000 psi.

Product Features

- Safety sleeve lock prevents accidental disconnection
- Heavy duty back-up ring prevents O-ring extrusion
- Heat treated and plated steel for greater wear and corrosion resistance
- Self-sealing poppet valves provide excellent high and low pressure sealing
- Standard seal material – Viton
- Standard body material – High resistance carbon steel with zinc trivalent chromate plating

Physical Characteristics

| Body Size | Max. Operating Pressure | | Min. Burst Pressure | | Vacuum Connected Only | Rated Flow | Air Inclusion | Fluid Loss |
|-----------|-------------------------|----------|---------------------|---------|-----------------------|-------------|---------------|------------|
| | bar | (psi) | bar | (psi) | (in./Hg) | L/min (gpm) | cc. max. | cc.max. |
| 3/8 | 700 | (10,000) | 2,800 | (4,000) | 28 | 8 (2) | 0.50 | 0.50 |



Applications

- 10,000 psi hydraulic applications
- Hydraulic tool
- Hydraulic ram and work loading



Flow Data

Pressure Drop Versus Flow Graph

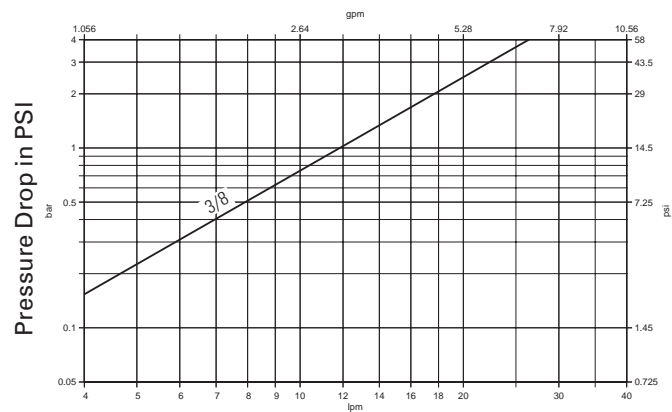

Gallons Per Minute Flow
Test Fluid: MIL-H-5606 Oil at 100°F

FD35 Series

10,000 psi Arc Latch™

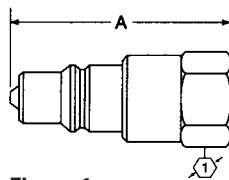

Figure 1

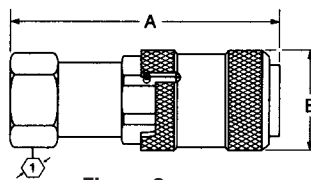

Figure 2

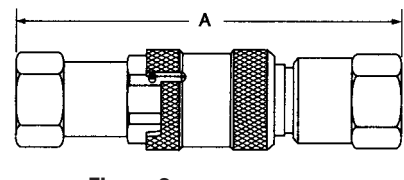

Figure 3

Dimensions (Female NPT, Valved)

| Part Number | Coupling Type | Body Size | Port Size | Thread | Type | Fig. | Dimensions | | | | | |
|-----------------|---------------|-----------|-----------|--------|------------|------|------------|--------|------|--------|-------|-------|
| | | | | | | | A | | B | | Hex ① | |
| | | | | | | | mm | (in) | mm | (in) | mm | (in) |
| FD35-1002-06-06 | Male | 3/8 | 3/8 | 3/8-18 | Female NPT | 1 | 53.8 | (2.12) | - | - | 23.9 | (.94) |
| FD35-1001-06-06 | Female | 3/8 | 3/8 | 3/8-18 | Female NPT | 2 | 65.0 | (2.56) | 32.3 | (1.27) | 23.9 | (.94) |
| FD35-1000-06-06 | Complete | 3/8 | 3/8 | 3/8-18 | Female NPT | 3 | 89.9 | (3.54) | - | - | - | - |

Dimensions (Female SAE O-ring, Valved)

| Part Number | Coupling Type | Body Size | Port Size | Thread | Type | Fig. | Dimensions | | | | | |
|-----------------|---------------|-----------|-----------|---------|-------------------|------|------------|--------|------|--------|-------|-------|
| | | | | | | | A | | B | | Hex ① | |
| | | | | | | | mm | (in) | mm | (in) | mm | (in) |
| FD35-1008-06-06 | Male | 3/8 | 9/16 | 9/16-18 | Female SAE O-ring | 1 | 53.8 | (2.12) | - | - | 23.9 | (.94) |
| FD35-1007-06-06 | Female | 3/8 | 9/16 | 9/16-18 | Female SAE O-ring | 2 | 65.0 | (2.56) | 32.3 | (1.27) | 23.9 | (.94) |
| FD35-1006-06-06 | Complete | 3/8 | 9/16 | 9/16-18 | Female SAE O-ring | 3 | 89.9 | (3.54) | - | - | - | - |

Dimensions (Female SAE O-ring, 125 PSI Bleed Valve)

| Part Number | Coupling Type | Body Size | Port Size | Thread | Type | Fig. | Dimensions | | | |
|---------------|---------------|-----------|-----------|---------|-------------------|------|------------|--------|-------|-------|
| | | | | | | | A | | Hex ① | |
| | | | | | | | mm | (in) | mm | (in) |
| FD-1044-06-06 | Male | 3/8 | 9/16 | 9/16-18 | Female SAE O-ring | 1 | 53.8 | (2.12) | 23.9 | (.94) |

Note: Incorporates a special relief valve set at 125 psi, preventing disconnected pressure build-up.

Repair Kits

| Part Number | Coupling Type |
|-------------|---------------|
| FF10173-06 | Male |
| FF10174-06 | Female |

Dust Cap/Plug

| Part Number (Viton) | Body Size |
|---------------------|-----------|
| FD35-1042-06 | 3/8 |

Note: Fits male and female halves



Dust Cap/Plug

FD45 Series (Steel)

ISO 7241/1
Series B Interchange



The FD45 Series steel is an industrial interchange popular in North America. Features a rugged ball latch mechanism with automatic self-sealing poppet valves in a wide array of port configurations and multiple valved and non-valved configurations.

Product Features

- Meets dimensional requirements to ISO standard 7241/1 Series B
- PUSH-PULL™ ball latch design allows quick and easy connection and disconnection of hose lines
- Self-sealing poppet valve design provides excellent high and low pressure sealing
- Standard seal material – Buna-N, EPR and Viton
- Standard body material – High resistance carbon steel with zinc trivalent chromate plating (Brass poppet guide in -02 size)

Physical Characteristics

| Body Size | Max. Operating Pressure | | Min. Burst Pressure | | Vacuum (in./Hg) | Rated Flow | | Air Inclusion cc. max. | Fluid Loss cc.max. |
|-----------|-------------------------|---------|---------------------|----------|--------------------|------------|-------|---------------------------|-----------------------|
| | bar | (psi) | bar | (psi) | | L/min | (gpm) | | |
| 1/8 | 315 | (4,500) | 945 | (13,500) | 28 | 4 | (1) | 0.50 | 0.50 |
| 1/4 | 350 | (5,000) | 1,050 | (15,000) | 28 | 11 | (3) | 0.50 | 0.50 |
| 3/8 | 280 | (4,000) | 840 | (12,000) | 28 | 23 | (6) | 2.5 | 1.3 |
| 5/8 | 280 | (4,000) | 840 | (12,000) | 28 | 45 | (12) | 4.0 | 2.8 |
| 3/4 | 280 | (4,000) | 840 | (12,000) | 28 | 106 | (28) | 11.0 | 8.2 |
| 1 | 280 | (4,000) | 840 | (12,000) | 28 | 189 | (50) | 18.0 | 16.0 |



Applications

- Hydraulic and fluid transfer



Flow Data

Pressure Drop Versus Flow Graph

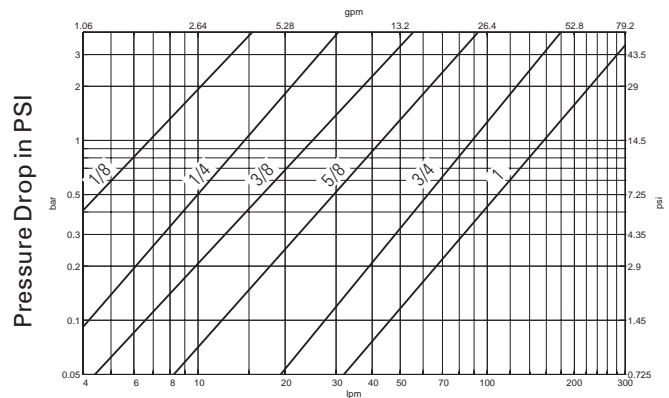

Gallons Per Minute Flow
Test Fluid: MIL-H-5606 Oil at 100°F

FD45 Series (Steel)

ISO 7241/1
Series B Interchange

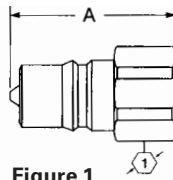

Figure 1

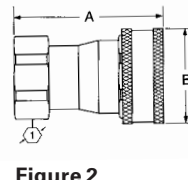

Figure 2

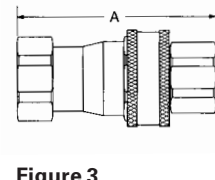

Figure 3

Dimensions (Female NPT, Valved)

| Part Number | Buna-N | Viton | EPR | Coupling Type | Body Size | Port Size | Thread | Type | Fig. | Dimensions | | | | Hex ① | |
|-----------------|-----------------|-----------------|----------|---------------|-----------|-----------|------------|------|-------|------------|------|--------|------|--------|------|
| | | | | | | | | | | A | | B | | | |
| | | | | | | | | | | mm | (in) | mm | (in) | mm | (in) |
| FD45-1002-02-02 | FD45-1071-02-02 | FD45-1064-02-02 | Male | 1/8 | 1/8 | 1/8-27 | Female NPT | 1 | 32.5 | (1.28) | - | - | 14.2 | (.56) | |
| FD45-1003-02-02 | FD45-1070-02-02 | FD45-1065-02-02 | Female | 1/8 | 1/8 | 1/8-27 | Female NPT | 2 | 46.0 | (1.81) | 24.4 | (0.96) | 19.0 | (.75) | |
| FD45-1000-02-02 | FD45-1072-02-02 | FD45-1063-02-02 | Complete | 1/8 | 1/8 | 1/8-27 | Female NPT | 3 | 58.7 | (2.31) | - | - | - | - | |
| FD45-1002-04-04 | FD45-1071-04-04 | FD45-1064-04-04 | Male | 1/4 | 1/4 | 1/4-18 | Female NPT | 1 | 38.9 | (1.53) | - | - | 19.0 | (.75) | |
| FD45-1003-04-04 | FD45-1070-04-04 | FD45-1065-04-04 | Female | 1/4 | 1/4 | 1/4-18 | Female NPT | 2 | 56.4 | (2.22) | 28.7 | (1.13) | 20.6 | (.81) | |
| FD45-1000-04-04 | FD45-1072-04-04 | FD45-1063-04-04 | Complete | 1/4 | 1/4 | 1/4-18 | Female NPT | 3 | 69.3 | (2.73) | - | - | - | - | |
| FD45-1002-06-06 | FD45-1071-06-06 | FD45-1064-06-06 | Male | 3/8 | 3/8 | 3/8-18 | Female NPT | 1 | 42.9 | (1.69) | - | - | 22.4 | (.88) | |
| FD45-1003-06-06 | FD45-1070-06-06 | FD45-1065-06-06 | Female | 3/8 | 3/8 | 3/8-18 | Female NPT | 2 | 62.2 | (2.45) | 35.1 | (1.38) | 26.9 | (1.06) | |
| FD45-1000-06-06 | FD45-1072-06-06 | FD45-1063-06-06 | Complete | 3/8 | 3/8 | 3/8-18 | Female NPT | 3 | 75.7 | (2.98) | - | - | - | - | |
| FD45-1002-08-10 | FD45-1071-08-10 | FD45-1064-08-10 | Male | 5/8 | 1/2 | 1/2-14 | Female NPT | 1 | 49.8 | (1.96) | - | - | 26.9 | (1.06) | |
| FD45-1003-08-10 | FD45-1070-08-10 | FD45-1065-08-10 | Female | 5/8 | 1/2 | 1/2-14 | Female NPT | 2 | 72.6 | (2.86) | 42.9 | (1.69) | 33.3 | (1.31) | |
| FD45-1000-08-10 | FD45-1072-08-10 | FD45-1063-08-10 | Complete | 5/8 | 1/2 | 1/2-14 | Female NPT | 3 | 89.4 | (3.52) | - | - | - | - | |
| FD45-1002-12-12 | FD45-1071-12-12 | FD45-1064-12-12 | Male | 3/4 | 3/4 | 3/4-14 | Female NPT | 1 | 61.2 | (2.41) | - | - | 33.3 | (1.31) | |
| FD45-1003-12-12 | FD45-1070-12-12 | FD45-1065-12-12 | Female | 3/4 | 3/4 | 3/4-14 | Female NPT | 2 | 86.4 | (3.40) | 52.3 | (2.06) | 41.1 | (1.62) | |
| FD45-1000-12-12 | FD45-1072-12-12 | FD45-1063-12-12 | Complete | 3/4 | 3/4 | 3/4-14 | Female NPT | 3 | 101.6 | (4.00) | - | - | - | - | |
| FD45-1002-16-16 | FD45-1071-16-16 | FD45-1064-16-16 | Male | 1 | 1 | 1-11 1/2 | Female NPT | 1 | 70.4 | (2.77) | - | - | 41.1 | (1.62) | |
| FD45-1003-16-16 | FD45-1070-16-16 | FD45-1065-16-16 | Female | 1 | 1 | 1-11 1/2 | Female NPT | 2 | 102.1 | (4.02) | 62.0 | (2.44) | 50.8 | (2.00) | |
| FD45-1000-16-16 | FD45-1072-16-16 | FD45-1063-16-16 | Complete | 1 | 1 | 1-11 1/2 | Female NPT | 3 | 123.4 | (4.86) | - | - | - | - | |

Dimensions (Female NPT, Non-Valved)

| Part Number | Buna-N | Viton | EPR | Coupling Type | Body Size | Port Size | Thread | Type | Fig. | Dimensions | | | | Hex ① | |
|-----------------|-----------------|-----------------|----------|---------------|-----------|-----------|------------|------|-------|------------|------|--------|------|--------|------|
| | | | | | | | | | | A | | B | | | |
| | | | | | | | | | | mm | (in) | mm | (in) | mm | (in) |
| FD45-1061-04-04 | FD45-1061-04-04 | FD45-1061-04-04 | Male | 1/4 | 1/4 | 1/4-18 | Female NPT | 1 | 34.8 | (1.37) | - | - | 19.0 | (.75) | |
| FD45-1047-04-04 | FD45-1172-04-04 | FD45-1207-04-04 | Female | 1/4 | 1/4 | 1/4-18 | Female NPT | 2 | 56.4 | (2.22) | 28.7 | (1.13) | 20.6 | (.81) | |
| FD45-1044-04-04 | FD45-1173-04-04 | FD45-1206-04-04 | Complete | 1/4 | 1/4 | 1/4-18 | Female NPT | 3 | 69.3 | (2.73) | - | - | - | - | |
| FD45-1061-06-06 | FD45-1061-06-06 | FD45-1061-06-06 | Male | 3/8 | 3/8 | 3/8-18 | Female NPT | 1 | 38.1 | (1.50) | - | - | 22.4 | (.88) | |
| FD45-1047-06-06 | FD45-1172-06-06 | FD45-1207-06-06 | Female | 3/8 | 3/8 | 3/8-18 | Female NPT | 2 | 62.2 | (2.45) | 35.1 | (1.38) | 26.9 | (1.06) | |
| FD45-1044-06-06 | FD45-1173-06-06 | FD45-1206-06-06 | Complete | 3/8 | 3/8 | 3/8-18 | Female NPT | 3 | 75.7 | (2.98) | - | - | - | - | |
| FD45-1061-08-10 | FD45-1061-08-10 | FD45-1061-08-10 | Male | 5/8 | 1/2 | 1/2-14 | Female NPT | 1 | 44.7 | (1.76) | - | - | 26.9 | (1.06) | |
| FD45-1047-08-10 | FD45-1172-08-10 | FD45-1207-08-10 | Female | 5/8 | 1/2 | 1/2-14 | Female NPT | 2 | 72.6 | (2.86) | 42.9 | (1.69) | 33.3 | (1.31) | |
| FD45-1044-08-10 | FD45-1173-08-10 | FD45-1206-08-10 | Complete | 5/8 | 1/2 | 1/2-14 | Female NPT | 3 | 89.4 | (3.52) | - | - | - | - | |
| FD45-1061-12-12 | FD45-1061-12-12 | FD45-1061-12-12 | Male | 3/4 | 3/4 | 3/4-14 | Female NPT | 1 | 50.8 | (2.00) | - | - | 33.3 | (1.31) | |
| FD45-1047-12-12 | FD45-1172-12-12 | FD45-1207-12-12 | Female | 3/4 | 3/4 | 3/4-14 | Female NPT | 2 | 86.4 | (3.40) | 52.3 | (2.06) | 41.1 | (1.62) | |
| FD45-1044-12-12 | FD45-1173-12-12 | FD45-1206-12-12 | Complete | 3/4 | 3/4 | 3/4-14 | Female NPT | 3 | 101.6 | (4.00) | - | - | - | - | |
| FD45-1061-16-16 | FD45-1061-16-16 | FD45-1061-16-16 | Male | 1 | 1 | 1-11 1/2 | Female NPT | 1 | 61.7 | (2.43) | - | - | 41.1 | (1.62) | |
| FD45-1047-16-16 | FD45-1172-16-16 | FD45-1207-16-16 | Female | 1 | 1 | 1-11 1/2 | Female NPT | 2 | 102.1 | (4.02) | 62.0 | (2.44) | 50.8 | (2.00) | |
| FD45-1044-16-16 | FD45-1173-16-16 | FD45-1206-16-16 | Complete | 1 | 1 | 1-11 1/2 | Female NPT | 3 | 123.4 | (4.86) | - | - | - | - | |

Note: Will not operate with valved coupling halves; no valve actuator.

FD45 Series (Steel)

ISO 7241/1
Series B Interchange

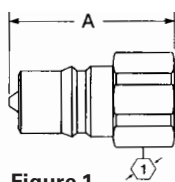

Figure 1

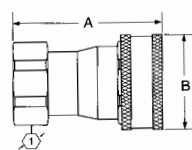

Figure 2

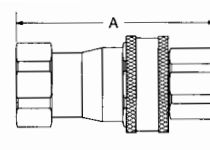

Figure 3

Dimensions (Female NPT, Pusher-Style Valving)

| Part Number Buna-N | Viton | EPR | Coupling Type | Body Size | Port Size | Thread | Type | Fig. | Dimensions | | Hex ^① | | | |
|-----------------------|-----------------|-----------------|------------------|--------------|--------------|----------|------------|------|------------|--------|------------------|--------|------|--------|
| | | | | | | | | | A | B | mm | (in) | | |
| FD45-1046-04-04 | FD45-1046-04-04 | FD45-1046-04-04 | Male | 1/4 | 1/4 | 1/4-18 | Female NPT | 1 | 38.1 | (1.50) | - | - | 19.0 | (.75) |
| FD45-1045-04-04 | FD45-1228-04-04 | FD45-1229-04-04 | Female | 1/4 | 1/4 | 1/4-18 | Female NPT | 2 | 56.4 | (2.22) | 28.7 | (1.13) | 20.6 | (.81) |
| FD45-1046-06-06 | FD45-1046-06-06 | FD45-1046-06-06 | Male | 3/8 | 3/8 | 3/8-18 | Female NPT | 1 | 42.2 | (1.66) | - | - | 22.4 | (.88) |
| FD45-1045-06-06 | FD45-1228-06-06 | FD45-1229-06-06 | Female | 3/8 | 3/8 | 3/8-18 | Female NPT | 2 | 62.2 | (2.45) | 35.1 | (1.38) | 26.9 | (1.06) |
| FD45-1046-08-10 | FD45-1046-08-10 | FD45-1046-08-10 | Male | 5/8 | 1/2 | 1/2-14 | Female NPT | 1 | 49.0 | (1.93) | - | - | 26.9 | (1.06) |
| FD45-1045-08-10 | FD45-1228-08-10 | FD45-1229-08-10 | Female | 5/8 | 1/2 | 1/2-14 | Female NPT | 2 | 72.6 | (2.86) | 42.9 | (1.69) | 33.3 | (1.31) |
| FD45-1046-12-12 | FD45-1046-12-12 | FD45-1046-12-12 | Male | 3/4 | 3/4 | 3/4-14 | Female NPT | 1 | 57.4 | (2.26) | - | - | 33.3 | (1.31) |
| FD45-1045-12-12 | FD45-1228-12-12 | FD45-1229-12-12 | Female | 3/4 | 3/4 | 3/4-14 | Female NPT | 2 | 86.4 | (3.40) | 52.3 | (2.06) | 41.1 | (1.62) |
| FD45-1046-16-16 | FD45-1046-16-16 | FD45-1046-16-16 | Male | 1 | 1 | 1-11 1/2 | Female NPT | 1 | 69.1 | (2.72) | - | - | 41.1 | (1.62) |
| FD45-1045-16-16 | FD45-1228-16-16 | FD45-1229-16-16 | Female | 1 | 1 | 1-11 1/2 | Female NPT | 2 | 102.1 | (4.02) | 62.0 | (2.44) | 50.8 | (2.00) |

Note: Incorporates a pusher device to open mating valved coupling halves.

Dimensions (Female SAE O-ring, Valved)

| Part Number Buna-N | EPR | Coupling Type | Body Size | Port Size | Thread | Type | Fig. | Dimensions | | Hex ^① | | | |
|-----------------------|------------------|------------------|--------------|--------------|-----------|-------------------|------|------------|--------|------------------|--------|------|--------|
| | | | | | | | | A | B | mm | (in) | | |
| FD45-1415-06-04 | FD45-1238-06-04 | Male | 1/4 | 9/16 | 9/16-18 | Female SAE O-ring | 1 | 42.7 | (1.68) | - | - | 20.6 | (.81) |
| FD45-1414-06-04* | FD45-1237-06-04* | Female | 1/4 | 9/16 | 9/16-18 | Female SAE O-ring | 2 | 58.7 | (2.31) | 28.7 | (1.13) | 23.9 | (.94) |
| FD45-1168-08-06 | - | Male | 3/8 | 1/2 | 3/4-16 | Female SAE O-ring | 1 | 50.0 | (1.97) | - | - | 25.4 | (1.00) |
| FD45-1169-08-06 | - | Female | 3/8 | 1/2 | 3/4-16 | Female SAE O-ring | 2 | 69.3 | (2.73) | 34.5 | (1.36) | 26.9 | (1.06) |
| FD45-1168-16-16 | - | Male | 1 | 1 5/16 | 1 5/16-12 | Female SAE O-ring | 1 | 69.1 | (2.72) | - | - | 41.1 | (1.62) |
| FD45-1169-16-16 | - | Female | 1 | 1 5/16 | 1 5/16-12 | Female SAE O-ring | 2 | 102.1 | (4.02) | 61.5 | (2.42) | 50.8 | (2.00) |

*With sleeve lock.

Repair Kits

| Part Number Buna-N | Viton | EPR | Body Size |
|-----------------------|-----------------------|----------|--------------|
| FF013-02 [†] | FF014-02 [†] | FF015-02 | 1/8 |
| FF013-04 | FF014-04 | FF015-04 | 1/4 |
| FF013-06 | FF014-06 | FF015-06 | 3/8 |
| FF013-10 | FF014-10 | FF015-10 | 5/8 |
| FF013-12 | FF014-12 | FF015-12 | 3/4 |
| FF013-16 | FF014-16 | FF015-16 | 1 |

Note: Each kit will repair one male or female half.

[†]The -02 coupling size valving is not repairable. This size repair kit contains an interface seal and back-up ring.

Dust Caps

| Part Number (Viton) | Body Size |
|------------------------|--------------|
| FD45-1040-02 | 1/8 |
| FD45-1040-04 | 1/4 |
| FD45-1040-06 | 3/8 |
| FD45-1040-10 | 5/8 |
| FD45-1040-12 | 3/4 |
| FD45-1040-16 | 1 |

Dust Plugs

| Part Number (Viton) | Body Size |
|------------------------|--------------|
| FD45-1041-02 | 1/8 |
| FD45-1041-04 | 1/4 |
| FD45-1041-06 | 3/8 |
| FD45-1041-10 | 5/8 |
| FD45-1041-12 | 3/4 |
| FD45-1041-16 | 1 |



Dust Cap



Dust Plug

FD45 Series (Brass)

ISO 7241/1

Series B Interchange



The FD45 brass is a general purpose industrial interchange coupling available in valved or non-valved designs, offered in brass for excellent corrosion resistance in rugged applications where stainless steel is unacceptable. Features a ball latch mechanism with automatic self-sealing poppet valves.

Product Features

- Meets dimensional requirements to ISO standard 7241/1 Series B
- Dual interface O-rings in the female half provide redundant sealing while connected
- Brass construction with stainless steel springs for greater corrosion resistance and fluid compatibility
- PUSH-PULL™ ball latch design allows quick and easy connection and disconnection of hose lines
- Self-sealing poppet valves provide excellent high and low pressure sealing
- Standard seal material – Buna-N, EPR and Viton
- Standard body material – Brass with stainless steel springs and balls

Physical Characteristics

| Body Size | Max. Operating Pressure | | Min. Burst Pressure Connected | | Min. Burst Pressure Disconnected | | Rated Vacuum | Flow | | Air Inclusion | Fluid Loss |
|-----------|-------------------------|---------|-------------------------------|----------|----------------------------------|----------|--------------|-------|-------|---------------|------------|
| | bar | (psi) | bar | (psi) | bar | (psi) | (in./Hg) | L/min | (gpm) | cc. max. | cc.max. |
| 1/8 | 70 | (1,000) | 770 | (11,000) | 840 | (12,000) | 28 | 4 | (1) | 0.50 | 0.006 |
| 1/4 | 70 | (1,000) | 1,260 | (18,000) | 980 | (14,000) | 28 | 11 | (3) | 0.50 | 0.012 |
| 3/8 | 70 | (1,000) | 840 | (12,000) | 630 | (9,000) | 28 | 23 | (6) | 2.5 | 0.020 |
| 5/8 | 70 | (1,000) | 840 | (12,000) | 455 | (6,500) | 28 | 45 | (12) | 4.0 | 0.026 |
| 3/4 | 70 | (1,000) | 700 | (10,000) | 700 | (10,000) | 28 | 106 | (28) | 11.0 | 0.032 |
| 1 | 70 | (1,000) | 595 | (8,500) | 770 | (11,000) | 28 | 189 | (50) | 18.0 | 0.010 |
| 1 1/4 | 70 | (1,000) | 420 | (6,000) | 420 | (6,000) | 28 | 284 | (75) | 30.0 | 0.050 |



Applications

- Hydraulics and fluid transfer
- Water/coolant
- Electronics (cooling)



Flow Data

Pressure Drop Versus Flow Graph

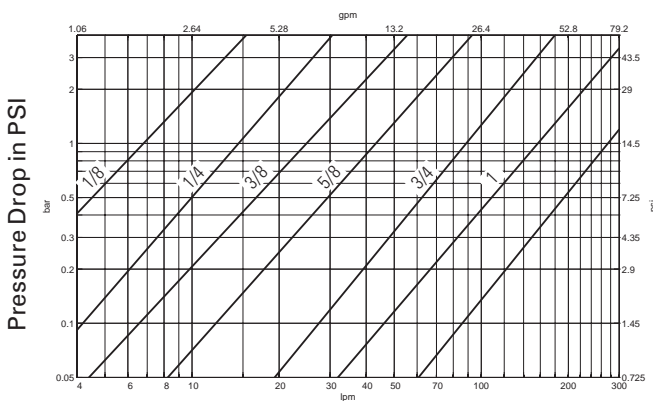

Gallons Per Minute Flow

Test Fluid: MIL-H-5606 Oil at 100°F

FD45 Series (Brass)

ISO 7241/1
Series B Interchange

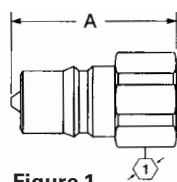

Figure 1

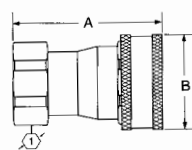

Figure 2

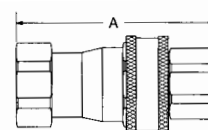

Figure 3

Dimensions (Female NPT, Valved)

| Part Number | Buna-N | Viton | EPR | Coupling Type | Body Size | Port Size | Thread | Type | Dimensions | | | | | |
|-----------------|-----------------|-----------------|----------|---------------|-----------|--------------|------------|------|--------------|-------------|-------------|-------------|----|------|
| | | | | | | | | | Fig. A | B | Hex Ⓛ | | | |
| | | | | | | | | | mm | (in) | mm | (in) | mm | (in) |
| FD45-1086-02-02 | FD45-1092-02-02 | FD45-1153-02-02 | Male | 1/8 | 1/8 | 1/8-27 | Female NPT | 1 | 32.5 (1.28) | - | - | 14.2 (.56) | | |
| FD45-1101-02-02 | FD45-1091-02-02 | FD45-1156-02-02 | Female | 1/8 | 1/8 | 1/8-27 | Female NPT | 2 | 46.0 (1.81) | 23.9 (.94) | 19 (.75) | | | |
| FD45-1100-02-02 | FD45-1090-02-02 | FD45-1157-02-02 | Complete | 1/8 | 1/8 | 1/8-27 | Female NPT | 3 | 58.7 (2.31) | - | - | - | - | |
| FD45-1086-04-04 | FD45-1092-04-04 | FD45-1153-04-04 | Male | 1/4 | 1/4 | 1/4-18 | Female NPT | 1 | 38.9 (1.53) | - | - | 17.5 (.69) | | |
| FD45-1101-04-04 | FD45-1091-04-04 | FD45-1156-04-04 | Female | 1/4 | 1/4 | 1/4-18 | Female NPT | 2 | 56.4 (2.22) | 28.7 (1.13) | 20.6 (.81) | | | |
| FD45-1100-04-04 | FD45-1090-04-04 | FD45-1157-04-04 | Complete | 1/4 | 1/4 | 1/4-18 | Female NPT | 3 | 69.6 (2.74) | - | - | - | - | |
| FD45-1086-06-06 | FD45-1092-06-06 | FD45-1153-06-06 | Male | 3/8 | 3/8 | 3/8-18 | Female NPT | 1 | 42.9 (1.69) | - | - | 22.4 (.88) | | |
| FD45-1101-06-06 | FD45-1091-06-06 | FD45-1156-06-06 | Female | 3/8 | 3/8 | 3/8-18 | Female NPT | 2 | 62.2 (2.45) | 35.1 (1.38) | 26.9 (1.06) | | | |
| FD45-1100-06-06 | FD45-1090-06-06 | FD45-1157-06-06 | Complete | 3/8 | 3/8 | 3/8-18 | Female NPT | 3 | 75.9 (2.99) | - | - | - | - | |
| FD45-1086-08-10 | FD45-1092-08-10 | FD45-1153-08-10 | Male | 5/8 | 1/2 | 1/2-14 | Female NPT | 1 | 49.8 (1.96) | - | - | 26.9 (1.06) | | |
| FD45-1101-08-10 | FD45-1091-08-10 | FD45-1156-08-10 | Female | 5/8 | 1/2 | 1/2-14 | Female NPT | 2 | 72.6 (2.86) | 42.9 (1.69) | 33.3 (1.31) | | | |
| FD45-1100-08-10 | FD45-1090-08-10 | FD45-1157-08-10 | Complete | 5/8 | 1/2 | 1/2-14 | Female NPT | 3 | 89.9 (3.54) | - | - | - | - | |
| FD45-1086-12-12 | FD45-1092-12-12 | FD45-1153-12-12 | Male | 3/4 | 3/4 | 3/4-14 | Female NPT | 1 | 61.2 (2.41) | - | - | 33.3 (1.31) | | |
| FD45-1101-12-12 | FD45-1091-12-12 | FD45-1156-12-12 | Female | 3/4 | 3/4 | 3/4-14 | Female NPT | 2 | 86.4 (3.40) | 51.1 (2.01) | 41.1 (1.62) | | | |
| FD45-1100-12-12 | FD45-1090-12-12 | FD45-1157-12-12 | Complete | 3/4 | 3/4 | 3/4-14 | Female NPT | 3 | 102.1 (4.02) | - | - | - | - | |
| FD45-1086-16-16 | FD45-1092-16-16 | FD45-1153-16-16 | Male | 1 | 1 | 1-11 1/2 | Female NPT | 1 | 70.4 (2.77) | - | - | 41.1 (1.62) | | |
| FD45-1101-16-16 | FD45-1091-16-16 | FD45-1156-16-16 | Female | 1 | 1 | 1-11 1/2 | Female NPT | 2 | 102.1 (4.02) | 60.5 (2.38) | 50.8 (2.00) | | | |
| FD45-1100-16-16 | FD45-1090-16-16 | FD45-1157-16-16 | Complete | 1 | 1 | 1-11 1/2 | Female NPT | 3 | 123.4 (4.86) | - | - | - | - | |
| FD45-1086-20-20 | FD45-1092-20-20 | FD45-1153-20-20 | Male | 5/4 | 1 1/4 | 1 1/4-11 1/2 | Female NPT | 1 | 108.0 (4.25) | - | - | 60.5 (2.38) | | |
| FD45-1101-20-20 | FD45-1091-20-20 | FD45-1156-20-20 | Female | 5/4 | 1 1/4 | 1 1/4-11 1/2 | Female NPT | 2 | 114.0 (4.49) | 66.5 (2.62) | 60.5 (2.38) | | | |
| FD45-1100-20-20 | FD45-1090-20-20 | FD45-1157-20-20 | Complete | 5/4 | 1 1/4 | 1 1/4-11 1/2 | Female NPT | 3 | 172.7 (6.80) | - | - | - | - | |

Dimensions (Female NPT, Non-Valved*)

| Part Number | Buna-N | Viton | EPR | Coupling Type | Body Size | Port Size | Thread | Type | Dimensions | | | | | |
|-----------------|-----------------|-----------------|----------|---------------|-----------|--------------|------------|------|--------------|-------------|-------------|-------------|----|------|
| | | | | | | | | | Fig. A | B | Hex Ⓛ | | | |
| | | | | | | | | | mm | (in) | mm | (in) | mm | (in) |
| FD45-1175-02-02 | FD45-1175-02-02 | FD45-1175-02-02 | Male | 1/8 | 1/8 | 1/8-27 | Female NPT | 1 | 30.5 (1.20) | - | - | 14.2 (.56) | | |
| FD45-1176-02-02 | FD45-1180-02-02 | FD45-1178-02-02 | Female | 1/8 | 1/8 | 1/8-27 | Female NPT | 2 | 46.0 (1.81) | 24.4 (.96) | 19.1 (.75) | | | |
| FD45-1174-02-02 | FD45-1179-02-02 | FD45-1177-02-02 | Complete | 1/8 | 1/8 | 1/8-27 | Female NPT | 3 | 58.7 (2.31) | - | - | - | - | |
| FD45-1175-04-04 | FD45-1175-04-04 | FD45-1175-04-04 | Male | 1/4 | 1/4 | 1/4-18 | Female NPT | 1 | 34.8 (1.37) | - | - | 17.5 (.69) | | |
| FD45-1176-04-04 | FD45-1180-04-04 | FD45-1178-04-04 | Female | 1/4 | 1/4 | 1/4-18 | Female NPT | 2 | 56.4 (2.22) | 28.7 (1.13) | 20.6 (.81) | | | |
| FD45-1174-04-04 | FD45-1179-04-04 | FD45-1177-04-04 | Complete | 1/4 | 1/4 | 1/4-18 | Female NPT | 3 | 69.6 (2.74) | - | - | - | - | |
| FD45-1175-06-06 | FD45-1175-06-06 | FD45-1175-06-06 | Male | 3/8 | 3/8 | 3/8-18 | Female NPT | 1 | 20.6 (1.50) | - | - | 22.4 (.88) | | |
| FD45-1176-06-06 | FD45-1180-06-06 | FD45-1178-06-06 | Female | 3/8 | 3/8 | 3/8-18 | Female NPT | 2 | 62.2 (2.45) | 35.1 (1.38) | 26.9 (1.06) | | | |
| FD45-1174-06-06 | FD45-1179-06-06 | FD45-1177-06-06 | Complete | 3/8 | 3/8 | 3/8-18 | Female NPT | 3 | 77.2 (3.04) | - | - | - | - | |
| FD45-1175-08-10 | FD45-1175-08-10 | FD45-1175-08-10 | Male | 5/8 | 1/2 | 1/2-14 | Female NPT | 1 | 44.7 (1.76) | - | - | 26.9 (1.06) | | |
| FD45-1176-08-10 | FD45-1180-08-10 | FD45-1178-08-10 | Female | 5/8 | 1/2 | 1/2-14 | Female NPT | 2 | 72.6 (2.86) | 42.9 (1.69) | 33.3 (1.31) | | | |
| FD45-1174-08-10 | FD45-1179-08-10 | FD45-1177-08-10 | Complete | 5/8 | 1/2 | 1/2-14 | Female NPT | 3 | 89.9 (3.54) | - | - | - | - | |
| FD45-1175-12-12 | FD45-1175-12-12 | FD45-1175-12-12 | Male | 3/4 | 3/4 | 3/4-14 | Female NPT | 1 | 50.8 (2.00) | - | - | 33.3 (1.31) | | |
| FD45-1176-12-12 | FD45-1180-12-12 | FD45-1178-12-12 | Female | 3/4 | 3/4 | 3/4-14 | Female NPT | 2 | 86.4 (3.40) | 51.1 (2.01) | 41.1 (1.62) | | | |
| FD45-1174-12-12 | FD45-1179-12-12 | FD45-1177-12-12 | Complete | 3/4 | 3/4 | 3/4-14 | Female NPT | 3 | 102.1 (4.02) | - | - | - | - | |
| FD45-1175-16-16 | FD45-1175-16-16 | FD45-1175-16-16 | Male | 1 | 1 | 1-11 1/2 | Female NPT | 1 | 61.7 (2.43) | - | - | 41.1 (1.62) | | |
| FD45-1176-16-16 | FD45-1180-16-16 | FD45-1178-16-16 | Female | 1 | 1 | 1-11 1/2 | Female NPT | 2 | 102.1 (4.02) | 60.5 (2.38) | 50.8 (2.00) | | | |
| FD45-1174-16-16 | FD45-1179-16-16 | FD45-1177-16-16 | Complete | 1 | 1 | 1-11 1/2 | Female NPT | 3 | 124.0 (4.88) | - | - | - | - | |
| FD45-1175-20-20 | FD45-1399-20-20 | FD45-1400-20-20 | Male | 5/4 | 1 1/4 | 1 1/4-11 1/2 | Female NPT | 1 | 108.0 (4.25) | - | - | 60.5 (2.38) | | |
| FD45-1176-20-20 | FD45-1180-20-20 | FD45-1178-20-20 | Female | 5/4 | 1 1/4 | 1 1/4-11 1/2 | Female NPT | 2 | 114.0 (4.49) | 66.5 (2.62) | 60.5 (2.38) | | | |
| FD45-1174-20-20 | FD45-1179-20-20 | FD45-1177-20-20 | Complete | 5/4 | 1 1/4 | 1 1/4-11 1/2 | Female NPT | 3 | 172.7 (6.80) | - | - | - | - | |

*Will not operate with valved coupling halves; no valve actuator.

FD45 Series (Brass)

ISO 7241/1

Series B Interchange

Dimensions (Female NPT, Pusher-Style Valving)

| Part Number Buna-N | Viton | EPR | Coupling Type | Body Size | Port Size | Thread | Type | Fig. | Dimensions | | | | | |
|-----------------------|-----------------|-----------------|------------------|--------------|--------------|--------|------------|------|------------|--------|------|--------|-------|--------|
| | | | | | | | | | A | | B | | Hex ① | |
| | | | | | | | | | mm | (in) | mm | (in) | mm | (in) |
| FD45-1201-04-04 | FD45-1201-04-04 | FD45-1201-04-04 | Male | 1/4 | 1/4 | 1/4-18 | Female NPT | 1 | 38.1 | (1.50) | - | - | 17.5 | (.69) |
| FD45-1203-04-04 | FD45-1199-04-04 | FD45-1211-04-04 | Female | 1/4 | 1/4 | 1/4-18 | Female NPT | 2 | 56.4 | (2.22) | 27.9 | (1.10) | 20.6 | (.81) |
| FD45-1201-06-06 | FD45-1201-06-06 | FD45-1201-06-06 | Male | 3/8 | 3/8 | 3/8-18 | Female NPT | 1 | 42.2 | (1.66) | - | - | 22.4 | (.88) |
| FD45-1203-06-06 | FD45-1199-06-06 | FD45-1211-06-06 | Female | 3/8 | 3/8 | 3/8-18 | Female NPT | 2 | 62.2 | (2.45) | 34.5 | (1.36) | 26.9 | (1.06) |
| FD45-1201-12-12 | FD45-1201-12-12 | FD45-1201-12-12 | Male | 3/4 | 3/4 | 3/4-14 | Female NPT | 1 | 57.9 | (2.28) | - | - | 33.3 | (1.31) |
| FD45-1203-12-12 | FD45-1199-12-12 | FD45-1211-12-12 | Female | 3/4 | 3/4 | 3/4-14 | Female NPT | 2 | 86.4 | (3.40) | 50.5 | (1.99) | 41.1 | (1.62) |

Note: Incorporates a pusher device to open mating valved coupling halves.

Repair Kits

| Part Number Buna-N | Viton | EPR | Body Size |
|-----------------------|-----------|-----------|--------------|
| FF016-02† | FF017-02† | FF018-02† | 1/8 |
| FF016-04 | FF017-04 | FF018-04 | 1/4 |
| FF016-06 | FF017-06 | FF018-06 | 3/8 |
| FF016-10 | FF017-10 | FF018-10 | 5/8 |
| FF016-12 | FF017-12 | FF018-12 | 3/4 |
| FF016-16 | FF017-16 | FF018-16 | 1 |
| FF016-20 | FF017-20 | FF018-20 | 1 1/4 |

Note: Each kit will repair one male or female half.

†The -02 coupling size valving is not repairable. This size repair kit contains an interface seal and back-up ring.

Dust Caps

| Part Number (Viton) | Body Size |
|------------------------|--------------|
| FD45-1040-02 | 1/8 |
| FD45-1040-04 | 1/4 |
| FD45-1040-06 | 3/8 |
| FD45-1040-10 | 5/8 |
| FD45-1040-12 | 3/4 |
| FD45-1040-16 | 1 |



Dust Cap

Dust Plugs

| Part Number (Viton) | Body Size |
|------------------------|--------------|
| FD45-1041-02 | 1/8 |
| FD45-1041-04 | 1/4 |
| FD45-1041-06 | 3/8 |
| FD45-1041-10 | 5/8 |
| FD45-1041-12 | 3/4 |
| FD45-1041-16 | 1 |



Dust Plug

FD45 Series (Stainless Steel)

ISO 7241/1

Series B Interchange



The FD45 stainless steel is a general purpose industrial interchange coupling available in valved or non-valved designs, offered in 303/304 grades of stainless steel for excellent corrosion resistance in rugged applications. Features a ball latch mechanism with automatic self-sealing poppet valves.

Product Features

- Meets dimensional requirements to ISO standard 7241/1 Series B
- 303/304 Stainless steel construction for greater corrosion resistance and fluid compatibility
- PUSH-PULL™ ball latch design allows quick and easy connection and disconnection of hose lines
- Self-sealing poppet valve design provides excellent high and low pressure sealing
- Standard seal material – Buna-N, EPR and Viton
- Standard body material – 303/304 Stainless Steel

Physical Characteristics

| Body Size | Max. Operating Pressure Hydraulic | | Pressure Static | | Min. Burst Pressure | | Vacuum (in./Hg) | Rated Flow | | Air Inclusion cc. max. | Fluid Loss cc.max. |
|-----------|-----------------------------------|---------|-----------------|---------|---------------------|----------|-----------------|------------|-------|------------------------|--------------------|
| | bar | (psi) | bar | (psi) | bar | (psi) | | L/min | (gpm) | | |
| 1/4 | 207 | (3,000) | 207 | (3,000) | 827 | (12,000) | 28 | 11 | (3) | 0.50 | 0.5 |
| 3/8 | 103 | (1,500) | 207 | (3,000) | 827 | (12,000) | 28 | 23 | (6) | 2.5 | 1.3 |
| 5/8 | 103 | (1,500) | 207 | (3,000) | 827 | (12,000) | 28 | 45 | (12) | 4.0 | 2.8 |
| 3/4 | 103 | (1,500) | 207 | (3,000) | 827 | (12,000) | 28 | 106 | (28) | 11.0 | 8.2 |
| 1 | 86 | (1,250) | 207 | (3,000) | 827 | (12,000) | 28 | 189 | (50) | 18.0 | 16.0 |



Applications

- Off-shore and marine hydraulics and fluid transfer
- Chemical processing
- Steam
- Electronics cooling



Flow Data

Pressure Drop Versus Flow Graph

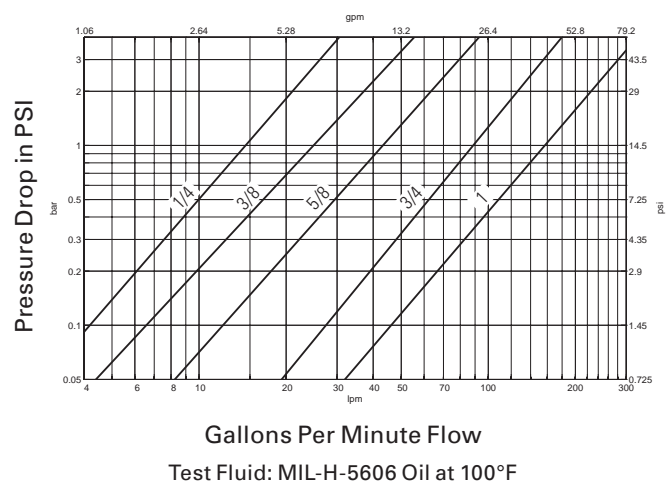

FD45 Series (Stainless Steel)

ISO 7241/1

Series B Interchange

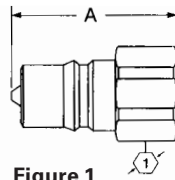

Figure 1

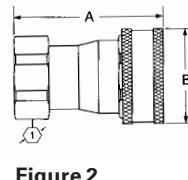

Figure 2

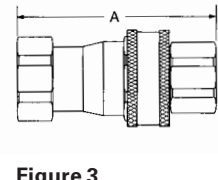

Figure 3

Dimensions (Female NPT, Valved)

| Part Number | Buna-N | Viton | EPR | Coupling Type | Body Size | Port Size | Thread | Type | Dimensions | | | | | |
|-----------------|-----------------|-----------------|----------|---------------|-----------|-----------|------------|------|------------|--------|------|--------|------|--------|
| | | | | | | | | | Fig. A | B | | Hex ① | | |
| | | | | | | | | | mm | (in) | mm | (in) | mm | (in) |
| FD45-1004-04-04 | FD45-1078-04-04 | FD45-1121-04-04 | Male | 1/4 | 1/4 | 1/4-18 | Female NPT | 1 | 37.8 | (1.49) | - | - | 17.5 | (.69) |
| FD45-1005-04-04 | FD45-1076-04-04 | FD45-1122-04-04 | Female | 1/4 | 1/4 | 1/4-18 | Female NPT | 2 | 56.4 | (2.22) | 28.7 | (1.13) | 20.6 | (.81) |
| FD45-1001-04-04 | FD45-1075-04-04 | FD45-1120-04-04 | Complete | 1/4 | 1/4 | 1/4-18 | Female NPT | 3 | 68.6 | (2.70) | - | - | - | - |
| FD45-1004-06-06 | FD45-1078-06-06 | FD45-1121-06-06 | Male | 3/8 | 3/8 | 3/8-18 | Female NPT | 1 | 42.9 | (1.69) | - | - | 22.4 | (.88) |
| FD45-1005-06-06 | FD45-1076-06-06 | FD45-1122-06-06 | Female | 3/8 | 3/8 | 3/8-18 | Female NPT | 2 | 62.2 | (2.45) | 35.1 | (1.38) | 26.9 | (1.06) |
| FD45-1001-06-06 | FD45-1075-06-06 | FD45-1120-06-06 | Complete | 3/8 | 3/8 | 3/8-18 | Female NPT | 3 | 75.7 | (2.98) | - | - | - | - |
| FD45-1004-08-10 | FD45-1078-08-10 | FD45-1121-08-10 | Male | 5/8 | 1/2 | 1/2-14 | Female NPT | 1 | 48.8 | (1.92) | - | - | 26.9 | (1.06) |
| FD45-1005-08-10 | FD45-1076-08-10 | FD45-1122-08-10 | Female | 5/8 | 1/2 | 1/2-14 | Female NPT | 2 | 72.6 | (2.86) | 42.9 | (1.69) | 33.3 | (1.31) |
| FD45-1001-08-10 | FD45-1075-08-10 | FD45-1120-08-10 | Complete | 5/8 | 1/2 | 1/2-14 | Female NPT | 3 | 88.4 | (3.48) | - | - | - | - |
| FD45-1004-12-12 | FD45-1078-12-12 | FD45-1121-12-12 | Male | 3/4 | 3/4 | 3/4-14 | Female NPT | 1 | 58.2 | (2.29) | - | - | 33.3 | (1.31) |
| FD45-1005-12-12 | FD45-1076-12-12 | FD45-1122-12-12 | Female | 3/4 | 3/4 | 3/4-14 | Female NPT | 2 | 86.4 | (3.40) | 51.1 | (2.01) | 41.1 | (1.62) |
| FD45-1001-12-12 | FD45-1075-12-12 | FD45-1120-12-12 | Complete | 3/4 | 3/4 | 3/4-14 | Female NPT | 3 | 101.6 | (4.00) | - | - | - | - |
| FD45-1004-16-16 | FD45-1078-16-16 | FD45-1121-16-16 | Male | 1 | 1 | 1-11 1/2 | Female NPT | 1 | 70.4 | (2.77) | - | - | 41.1 | (1.62) |
| FD45-1005-16-16 | FD45-1076-16-16 | FD45-1122-16-16 | Female | 1 | 1 | 1-11 1/2 | Female NPT | 2 | 102.1 | (4.02) | 60.5 | (2.38) | 50.8 | (2.00) |
| FD45-1001-16-16 | FD45-1075-16-16 | FD45-1120-16-16 | Complete | 1 | 1 | 1-11 1/2 | Female NPT | 3 | 123.4 | (4.86) | - | - | - | - |

Dimensions (Female NPT, Non-Valved)

| Part Number | Buna-N | Viton | EPR | Coupling Type | Body Size | Port Size | Thread | Type | Dimensions | | | | | |
|-----------------|-----------------|-----------------|----------|---------------|-----------|-----------|------------|------|------------|--------|------|--------|------|--------|
| | | | | | | | | | Fig. A | B | | Hex ① | | |
| | | | | | | | | | mm | (in) | mm | (in) | mm | (in) |
| FD45-1062-04-04 | FD45-1062-04-04 | FD45-1062-04-04 | Male | 1/4 | 1/4 | 1/4-18 | Female NPT | 1 | 33.8 | (1.33) | - | - | 17.5 | (.69) |
| FD45-1053-04-04 | FD45-1195-04-04 | FD45-1142-04-04 | Female | 1/4 | 1/4 | 1/4-18 | Female NPT | 2 | 56.4 | (2.22) | 28.7 | (1.13) | 20.6 | (.81) |
| FD45-1052-04-04 | FD45-1194-04-04 | FD45-1143-04-04 | Complete | 1/4 | 1/4 | 1/4-18 | Female NPT | 3 | 68.6 | (2.70) | - | - | - | - |
| FD45-1062-06-06 | FD45-1062-06-06 | FD45-1062-06-06 | Male | 3/8 | 3/8 | 3/8-18 | Female NPT | 1 | 38.1 | (1.50) | - | - | 22.4 | (.88) |
| FD45-1053-06-06 | FD45-1195-06-06 | FD45-1142-06-06 | Female | 3/8 | 3/8 | 3/8-18 | Female NPT | 2 | 62.2 | (2.45) | 35.1 | (1.38) | 26.9 | (1.06) |
| FD45-1052-06-06 | FD45-1194-06-06 | FD45-1143-06-06 | Complete | 3/8 | 3/8 | 3/8-18 | Female NPT | 3 | 75.7 | (2.98) | - | - | - | - |
| FD45-1062-08-10 | FD45-1062-08-10 | FD45-1062-08-10 | Male | 5/8 | 1/2 | 1/2-14 | Female NPT | 1 | 43.7 | (1.72) | - | - | 26.9 | (1.06) |
| FD45-1053-08-10 | FD45-1195-08-10 | FD45-1142-08-10 | Female | 5/8 | 1/2 | 1/2-14 | Female NPT | 2 | 72.6 | (2.86) | 42.9 | (1.69) | 33.3 | (1.31) |
| FD45-1052-08-10 | FD45-1194-08-10 | FD45-1143-08-10 | Complete | 5/8 | 1/2 | 1/2-14 | Female NPT | 3 | 88.4 | (3.48) | - | - | - | - |
| FD45-1062-12-12 | FD45-1062-12-12 | FD45-1062-12-12 | Male | 3/4 | 3/4 | 3/4-14 | Female NPT | 1 | 50.8 | (2.00) | - | - | 33.3 | (1.31) |
| FD45-1053-12-12 | FD45-1195-12-12 | FD45-1142-12-12 | Female | 3/4 | 3/4 | 3/4-14 | Female NPT | 2 | 89.4 | (3.52) | 51.1 | (2.01) | 41.1 | (1.62) |
| FD45-1052-12-12 | FD45-1194-12-12 | FD45-1143-12-12 | Complete | 3/4 | 3/4 | 3/4-14 | Female NPT | 3 | 101.6 | (4.00) | - | - | - | - |
| FD45-1062-16-16 | FD45-1062-16-16 | FD45-1062-16-16 | Male | 1 | 1 | 1-11 1/2 | Female NPT | 1 | 61.7 | (2.43) | - | - | 41.1 | (1.62) |
| FD45-1053-16-16 | FD45-1195-16-16 | FD45-1142-16-16 | Female | 1 | 1 | 1-11 1/2 | Female NPT | 2 | 102.1 | (4.02) | 60.5 | (2.38) | 50.8 | (2.00) |
| FD45-1052-16-16 | FD45-1194-16-16 | FD45-1143-16-16 | Complete | 1 | 1 | 1-11 1/2 | Female NPT | 3 | 123.4 | (4.86) | - | - | - | - |

Note: Will not operate with valved coupling halves; no valve actuator.

FD45 Series (Stainless Steel)

ISO 7241/1
Series B Interchange

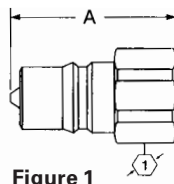

Figure 1

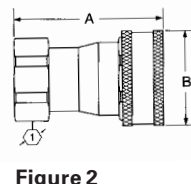

Figure 2

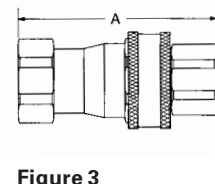

Figure 3

Dimensions (Female NPT, Pusher-Style Valving)

| Part Number Buna-N | Viton | EPR | Coupling Type | Body Size | Port Size | Thread | Type | Dimensions | | | | | | |
|-----------------------|-----------------|-----------------|------------------|--------------|--------------|----------|------------|------------|-------|--------|------|--------|-------|--------|
| | | | | | | | | Fig. | A | | B | | Hex ① | |
| | | | | | | | | mm | (in) | mm | (in) | mm | (in) | |
| FD45-1059-04-04 | FD45-1059-04-04 | FD45-1059-04-04 | Male | 1/4 | 1/4 | 1/4-18 | Female NPT | 1 | 33.8 | (1.33) | - | - | 17.5 | (.69) |
| FD45-1056-04-04 | FD45-1197-04-04 | FD45-1209-04-04 | Female | 1/4 | 1/4 | 1/4-18 | Female NPT | 2 | 56.4 | (2.22) | 28.7 | (1.13) | 20.6 | (.81) |
| FD45-1059-06-06 | FD45-1059-06-06 | FD45-1059-06-06 | Male | 3/8 | 3/8 | 3/8-18 | Female NPT | 1 | 38.1 | (1.50) | - | - | 22.4 | (.88) |
| FD45-1056-06-06 | FD45-1197-06-06 | FD45-1209-06-06 | Female | 3/8 | 3/8 | 3/8-18 | Female NPT | 2 | 62.2 | (2.45) | 35.1 | (1.38) | 26.9 | (1.06) |
| FD45-1059-08-10 | FD45-1059-08-10 | FD45-1059-08-10 | Male | 5/8 | 1/2 | 1/2-14 | Female NPT | 1 | 43.7 | (1.72) | - | - | 26.9 | (1.06) |
| FD45-1056-08-10 | FD45-1197-08-10 | FD45-1209-08-10 | Female | 5/8 | 1/2 | 1/2-14 | Female NPT | 2 | 72.6 | (2.86) | 42.9 | (1.69) | 33.3 | (1.31) |
| FD45-1059-12-12 | FD45-1059-12-12 | FD45-1059-12-12 | Male | 3/4 | 3/4 | 3/4-14 | Female NPT | 1 | 50.8 | (2.00) | - | - | 33.3 | (1.31) |
| FD45-1056-12-12 | FD45-1197-12-12 | FD45-1209-12-12 | Female | 3/4 | 3/4 | 3/4-14 | Female NPT | 2 | 89.4 | (3.52) | 51.1 | (2.01) | 41.1 | (1.62) |
| FD45-1059-16-16 | FD45-1059-16-16 | FD45-1059-16-16 | Male | 1 | 1 | 1-11 1/2 | Female NPT | 1 | 61.7 | (2.43) | - | - | 41.1 | (1.62) |
| FD45-1056-16-16 | FD45-1197-16-16 | FD45-1209-16-16 | Female | 1 | 1 | 1-11 1/2 | Female NPT | 2 | 102.1 | (4.02) | 60.5 | (2.38) | 50.8 | (2.00) |

Note: Incorporates a pusher device to open mating valved coupling halves.

Fryer Coupling/Male Half
Female Pipe/Valved

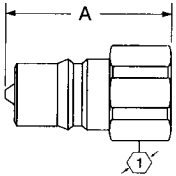

Figure 4

Fryer Coupling/Female Half Female Pipe/Valved
Silicone Collar on Ball Release Sleeve

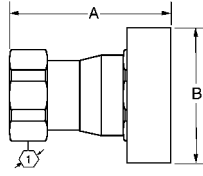

Figure 5

Dimensions (Fryer Coupling*)

| Part Number Buna-N | Coupling Type | Body Size | Port Size | Thread | Type | Fig. | Dimensions | | | | | |
|-----------------------|------------------|--------------|--------------|--------|------------|------|------------|--------|----|------|-------|--------|
| | | | | | | | A | | B | | Hex ① | |
| | | | | | | | mm | (in) | mm | (in) | mm | (in) |
| FD45-1270-08-10 | Male | 5/8 | 1/2 | 1/2-14 | Female NPT | 4 | 48.8 | (1.92) | - | - | 26.9 | (1.06) |

Dimensions (Female, Valved Silicone Collar on Ball Release Sleeve*)

| Part Number Buna-N | Coupling Type | Body Size | Port Size | Thread | Type | Fig. | Dimensions | | | | | |
|-----------------------|------------------|--------------|--------------|--------|------------|------|------------|--------|------|--------|-------|--------|
| | | | | | | | A | | B | | Hex ① | |
| | | | | | | | mm | (in) | mm | (in) | mm | (in) |
| FD45-1267-08-10 | Female | 5/8 | 1/2 | 1/2-14 | Female NPT | 4 | 72.6 | (2.86) | 58.4 | (2.38) | 33.3 | (1.31) |

*Special internal Viton seal material approved for use by the National Sanitation Foundation. The fryer coupling uses a silicone collar.

Repair Kits

| Part Number Buna-N | Viton | EPR | Body Size |
|-----------------------|----------|----------|--------------|
| FF054-04 | FF055-04 | FF056-04 | 1/4 |
| FF054-06 | FF055-06 | FF056-06 | 3/8 |
| FF054-10 | FF055-10 | FF056-10 | 5/8 |
| FF054-12 | FF055-12 | FF056-12 | 3/4 |
| FF054-16 | FF055-16 | FF056-16 | 1 |

Dust Caps

| Part Number Viton | Body Size |
|----------------------|--------------|
| FD45-1040-02 | 1/8 |
| FD45-1040-04 | 1/4 |
| FD45-1040-06 | 3/8 |
| FD45-1040-10 | 5/8 |
| FD45-1040-12 | 3/4 |
| FD45-1040-16 | 1 |

Dust Plugs

| Part Number Viton | Body Size |
|----------------------|--------------|
| FD45-1041-02 | 1/8 |
| FD45-1041-04 | 1/4 |
| FD45-1041-06 | 3/8 |
| FD45-1041-10 | 4/8 |
| FD45-1041-12 | 3/4 |
| FD45-1041-16 | 1 |



Dust Cap



Dust Plug

FD48 Series

Parker Bruning
SM-250 Interchange



The FD48 Series coupling is poppet style quick disconnect coupling designed to interchange with Parker Bruning SM-250 couplings where excellent high and low pressure sealing is required. The FD48 operates with pressures up to 3,000 psi.

Product Features

- Self-sealing poppet valves provide excellent high and low pressure sealing
- PUSH-PULL™ ball latch design allows quick and easy connection and disconnection of fluid lines
- Heat-treated and plated steel for wear and corrosion resistance
- Standard seal material – Buna-N
- Standard seal material – High resistance carbon steel with zinc trivalent plating

Applications

- Hydraulic and fluid transfer
- Agricultural equipment



Physical Characteristics

| Body Size | Max. Operating Pressure | | Min. Burst Pressure Connected | | Vacuum Conncted Only | Rated Flow | | Air Inclusion | Fluid Loss |
|-----------|-------------------------|---------|-------------------------------|----------|----------------------|------------|-------|---------------|------------|
| | bar | (psi) | bar | (psi) | (in./Hg) | L/min | (gpm) | cc. max. | cc.max. |
| 1/4 | 210 | (3,000) | 840 | (12,000) | 28 | 11 | (3) | .50 | 1.10 |

Dimensions (Female NPT, Valved)

| Part Number Buna-N | Coupling Type | Body Size | Port Size | Thread | Type | Fig. | Dimensions | | | | | | | |
|-----------------------|---------------|-----------|-----------|--------|------------|------|------------|--------|------|--------|-------|-------|--|--|
| | | | | | | | A | | B | | Hex Ⓛ | | | |
| | | | | | | mm | | (in) | | mm | | (in) | | |
| FD48-1002-04-04 | Male | 1/4 | 1/4 | 1/4-18 | Female NPT | 1 | 36.8 | (1.45) | - | - | 19.0 | (.75) | | |
| FD48-1001-04-04 | Female | 1/4 | 1/4 | 1/4-18 | Female NPT | 2 | 51.1 | (2.01) | 26.9 | (1.06) | 20.6 | (.81) | | |
| FD48-1000-04-04 | Complete | 1/4 | 1/4 | 1/4-18 | Female NPT | 3 | 68.3 | (2.69) | - | - | - | - | | |

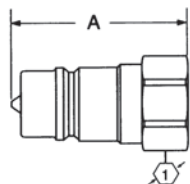

Figure 1

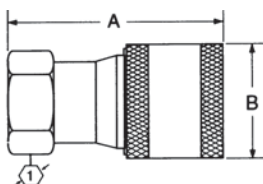

Figure 2

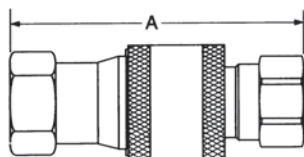
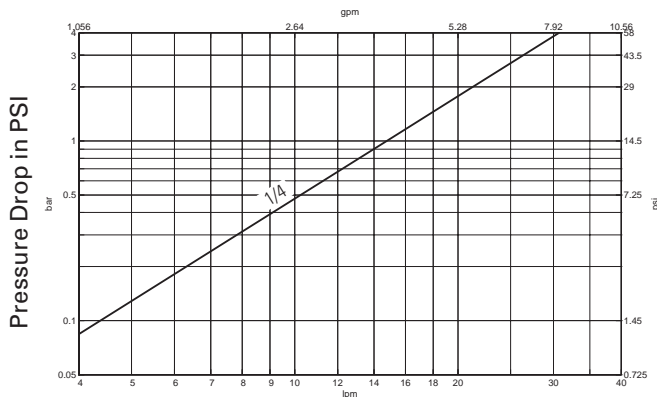

Figure 3

Flow Data

Pressure Drop Versus Flow Graph



Gallons Per Minute Flow

Test Fluid: MIL-H-5606 Oil at 100°F

Dust Cap/Plug

| Part Number (Buna-N) | Body Size |
|-------------------------|-----------|
| FD48-1042-04* | 1/4 |

*Fits both male and female halves.



FD49 Series

NFPA standard T3.20.15
HTMA Interchange



The FD49 Series meets NFPA standard T3.20.15 and was developed in conjunction with HTMA (Hydraulic Tool Manufacturer's Association). The Eaton Twin-Guard™ sealing system prevents weepage at low pressures and allows connection and disconnection against pressure up to 500 psi.

Product Features

- Dual flush face valving for minimal fluid loss and air inclusion
- Tubular valve and sleeve construction for high fluid flow with low pressure drop
- Push-to-connect latching for one hand operation
- Standard seal material – Teflon channel seal and Buna-N O-ring backup
- Standard body material – High resistance carbon steel with zinc trivalent plating

Physical Characteristics

| Body Size | Max. Operating Pressure | | Min. Burst Pressure Connected | | Vacuum Connected Only | Rated Flow | | Air Inclusion | Fluid Loss |
|-----------|-------------------------|---------|-------------------------------|---------|-----------------------|------------|-------|---------------|------------|
| | bar | (psi) | bar | (psi) | (in./Hg) | L/min | (gpm) | cc. max. | cc.max. |
| 3/8 | 207 | (3,000) | 621 | (9,000) | 28 | 38 | (10) | .01 | .02 |

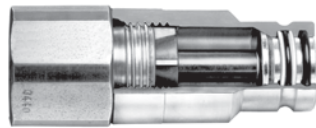

Our Eaton Twin-Guard™ seal system consists of channel and Buna-N O-ring seals. The channel seal prevents blowout during connection and disconnection under pressure to 500 psi. The Buna-N O-ring seal is a secondary seal eliminating fluid weepage.



Applications

- Hydraulic tool (HTMA interchange)
- Hydraulic and fluid transfer



Flow Data

Pressure Drop Versus Flow Graph

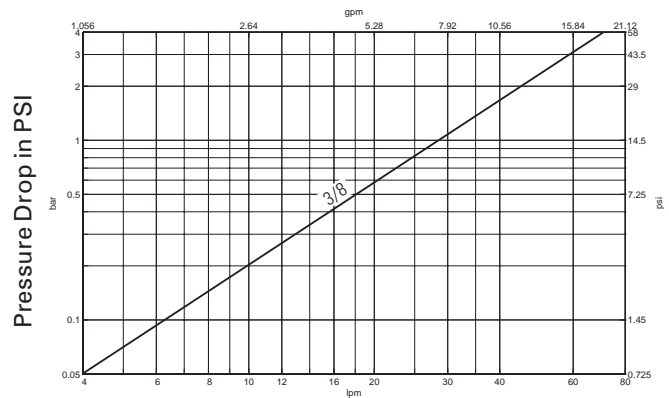

Gallons Per Minute Flow
Test Fluid: MIL-H-5606 Oil at 100°F

FD49 Series

NFPA Standard T3.20.15
HTMA Interchange

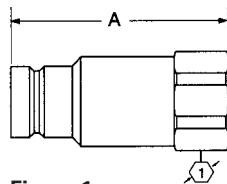

Figure 1

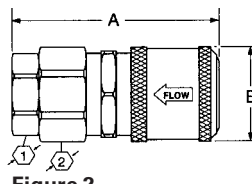

Figure 2

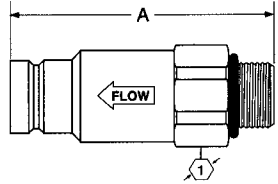

Figure 3

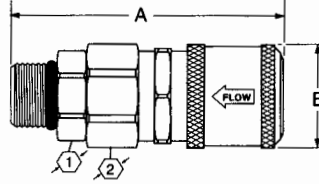

Figure 4

Dimensions (Female NPT, Valved)

| Part Number Buna-N | Coupling Type | Body Size | Port Size | Thread Type | Fig. | Dimensions | | | | Hex ① | | Hex ② | | |
|-----------------------|------------------|--------------|--------------|-------------|------------|------------|------|--------|------|--------|------|--------|------|--------|
| | | | | | | A | B | mm | (in) | mm | (in) | mm | (in) | mm |
| FD49-1002-06-06 | Male | 3/8 | 3/8 | 3/8-18 | Female NPT | 1 | 66.5 | (2.62) | - | - | 25.4 | (1.00) | - | - |
| FD49-1001-06-06 | Female | 3/8 | 3/8 | 3/8-18 | Female NPT | 2 | 69.6 | (2.74) | 30.5 | (1.20) | 25.4 | (1.00) | 26.9 | (1.06) |
| FD49-1002-08-06 | Male | 3/8 | 1/2 | 1/2-14 | Female NPT | 1 | 69.9 | (2.75) | - | - | 26.9 | (1.06) | - | - |
| FD49-1001-08-06 | Female | 3/8 | 1/2 | 1/2-14 | Female NPT | 2 | 72.4 | (2.85) | 30.5 | (1.20) | - | - | 26.9 | (1.06) |

Dimensions (Female SAE O-ring, Valved)

| Part Number Buna-N | Coupling Type | Body Size | Port Size | Thread Type | Fig. | Dimensions | | | | Hex ① | | Hex ② | | |
|-----------------------|------------------|--------------|--------------|-------------|-------------------|------------|------|--------|------|--------|------|--------|------|--------|
| | | | | | | A | B | mm | (in) | mm | (in) | mm | (in) | mm |
| FD49-1004-08-06 | Male | 3/8 | 3/4 | 3/4-16 | Female SAE O-ring | 1 | 69.9 | (2.75) | - | - | 26.9 | (1.06) | - | - |
| FD49-1005-08-06 | Female | 3/8 | 3/4 | 3/4-16 | Female SAE O-ring | 2 | 71.6 | (2.82) | 30.5 | (1.20) | - | - | 26.9 | (1.06) |

Dimensions (Male SAE O-ring, Valved)

| Part Number Buna-N | Coupling Type | Body Size | Port Size | Thread Type | Fig. | Dimensions | | | | Hex ① | | Hex ② | | |
|-----------------------|------------------|--------------|--------------|-------------|-----------------|------------|------|--------|------|--------|------|--------|------|--------|
| | | | | | | A | B | mm | (in) | mm | (in) | mm | (in) | mm |
| FD49-1057-06-06 | Male | 3/8 | 9/16 | 9/16-18 | Male SAE O-ring | 3 | 75.9 | (2.99) | - | - | 25.4 | (1.00) | - | - |
| FD49-1014-06-06 | Female | 3/8 | 9/16 | 9/16-18 | Male SAE O-ring | 4 | 81.8 | (3.22) | 30.5 | (1.20) | 25.4 | (1.00) | 26.9 | (1.06) |
| FD49-1057-08-06 | Male | 3/8 | 3/4 | 3/4-16 | Male SAE O-ring | 3 | 75.9 | (2.99) | - | - | 25.4 | (1.00) | - | - |
| FD49-1014-08-06 | Female | 3/8 | 3/4 | 3/4-16 | Male SAE O-ring | 4 | 83.3 | (3.28) | 30.5 | (1.20) | 25.4 | (1.00) | 26.9 | (1.06) |

Dust Cap/Plug, Standard Coupling

| Part Number (Buna-N) | Body Size |
|-------------------------|--------------|
| FD49-1042-06 | 3/8 |

Note: Fits male and female halves.



Dust Cap/Plug

5100 Series

Thread to Connect



The 5100 Series brass coupling with steel tubular valve offers minimum air inclusion and fluid loss. Thread together latch provides connect under pressure capability and vibration resistance. The 5100 Series is not rated for continuous hydraulic impulse applications. For hydraulic impulse applications, refer to the FD86 and FD96 Series thread to connect product lines.

Product Features

- Tubular valve construction for virtually no fluid loss during disconnection, reduces environmental and worker safety hazards
- Low air inclusion during connection maintains system performance
- Available with wing or hex nut configurations
- Connect against pressure capability allows connecting of halves even when pressurized up to 500 psi
- Steel flange available for accessible bulkhead mounting
- Standard seal material – Buna-N
- Standard body material – Brass body with high resistance carbon steel with zinc trivalent plated valving components, hex and wing nuts

Physical Characteristics

| Body Dash Size | Body Interface Size | Max. Operating Pressure Connected | | Max. Operating Pressure Disconnected | | | | | | | | |
|----------------|---------------------|-----------------------------------|---------|--------------------------------------|---------|----------------|---------|--------|------------|-------|------------------------|--------------------|
| | | | | Male Half S2 and S4 | | Female Half S5 | | Vacuum | Rated Flow | | Air Inclusion cc. max. | Fluid Loss cc.max. |
| | | | | bar | (psi) | bar | (psi) | | (in./Hg) | L/min | | |
| 1/4 | 1/4 | 207 | (3,000) | 207 | (3,000) | 207 | (3,000) | 28 | 15 | (4) | .03 | .01 |
| 3/8 | 1/2 | 207 | (3,000) | 207 | (3,000) | 207 | (3,000) | 28 | 26 | (7) | .05 | .06 |
| 1/2 | 1/2 | 207 | (3,000) | 207 | (3,000) | 207 | (3,000) | 28 | 26 | (7) | .05 | .10 |
| 5/8 | 3/4 | 207 | (3,000) | 207 | (3,000) | 207 | (3,000) | 28 | 68 | (18) | .14 | .10 |
| 3/4 | 3/4 | 207 | (3,000) | 207 | (3,000) | 207 | (3,000) | 28 | 68 | (18) | .34 | .26 |
| 1 | 1 | 207 | (3,000) | 207 | (3,000) | 207 | (3,000) | 28 | 151 | (40) | .50 | .35 |
| 1 1/4 | 1 1/4 | 190 | (2,750) | 172 | (2,500) | 190 | (2,750) | 28 | 284 | (75) | .68 | .70 |
| 1 1/2 | 1 1/2 | 172 | (2,500) | 172 | (2,500) | 138 | (2,000) | 28 | 379 | (100) | .60 | .94 |



Applications

- Hydraulics and fluid transfer
- On-highway hydraulic wet lines
- Dump and refuse vehicles
- Bulk liquid transfer



Flow Data

Pressure Drop Versus Flow Graph

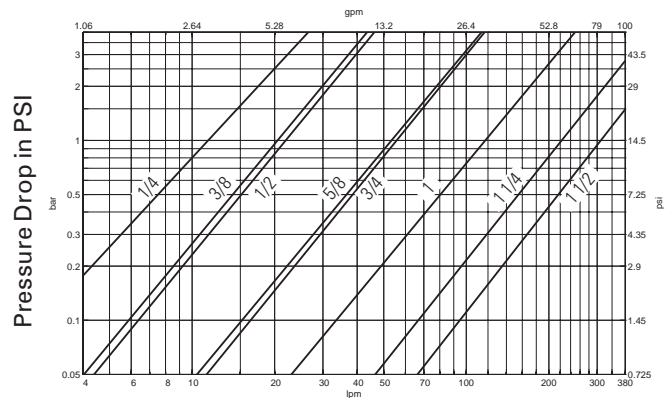

Gallons Per Minute Flow
Test Fluid: MIL-H-5606 Oil at 100°F

5100 Series

Thread to Connect

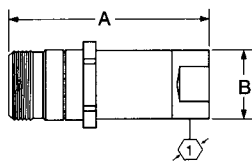

Figure 1

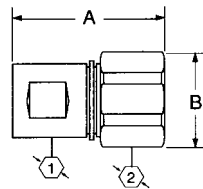

Figure 2

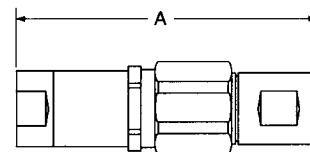

Figure 3

Dimensions (Female NPT, Valved without Flange)

| Part Number | Coupling Type | Body Size | Port Size | Thread | Type | Dimensions | | | | | | | | |
|-------------|---------------|-----------|-----------|----------------|------------|------------|-------|--------|-------|--------|------|--------|------|--------|
| | | | | | | Fig. A | B | | Hex ① | Hex ② | | | | |
| Buna-N | | | | | | mm | (in) | mm | (in) | mm | (in) | mm | (in) | |
| 5100-S2-4B | Male | 1/4 | 1/8 | 1/8-27 | Female NPT | 1 | 47.8 | (1.88) | 22.9 | (.90) | 17.5 | (.69) | - | - |
| 5110-S5-4B | Female | 1/4 | 1/8 | 1/8-27 | Female NPT | 2 | 53.3 | (2.10) | 33.5 | (1.32) | 14.2 | (.56) | 30.2 | (1.19) |
| 5111-4B | Complete | 1/4 | 1/8 | 1/8-27 | Female NPT | 3 | 81.3 | (3.20) | - | - | - | - | - | - |
| 5100-S2-6B | Male | 3/8 | 1/4 | 1/4-18 | Female NPT | 1 | 65.5 | (2.58) | 26.7 | (1.05) | 23.9 | (.94) | - | - |
| 5110-S5-6B | Female | 3/8 | 1/4 | 1/4-18 | Female NPT | 2 | 61.0 | (2.40) | 38.9 | (1.53) | 19.3 | (.76) | 35.1 | (1.38) |
| 5111-6B | Complete | 3/8 | 1/4 | 1/4-18 | Female NPT | 3 | 104.4 | (4.11) | - | - | - | - | - | - |
| 5100-S2-8B | Male | 1/2 | 3/8 | 3/8-18 | Female NPT | 1 | 65.5 | (2.58) | 26.7 | (1.05) | 23.9 | (.94) | - | - |
| 5110-S5-8B | Female | 1/2 | 3/8 | 3/8-18 | Female NPT | 2 | 61.0 | (2.40) | 38.9 | (1.53) | 19.3 | (.76) | 35.1 | (1.38) |
| 5111-8B | Complete | 1/2 | 3/8 | 3/8-18 | Female NPT | 3 | 104.4 | (4.11) | - | - | - | - | - | - |
| 5100-S2-10B | Male | 5/8 | 1/2 | 1/2-14 | Female NPT | 1 | 79.0 | (3.11) | 35.1 | (1.38) | 30.2 | (1.19) | - | - |
| 5110-S5-10B | Female | 5/8 | 1/2 | 1/2-14 | Female NPT | 2 | 78.0 | (3.07) | 50.3 | (1.98) | 29.5 | (1.16) | 44.5 | (1.75) |
| 5111-10B | Complete | 5/8 | 1/2 | 1/2-14 | Female NPT | 3 | 132.3 | (5.21) | - | - | - | - | - | - |
| 5100-S2-12B | Male | 3/4 | 3/4 | 3/4-14 | Female NPT | 1 | 79.0 | (3.11) | 35.1 | (1.38) | 30.2 | (1.19) | - | - |
| 5110-S5-12B | Female | 3/4 | 3/4 | 3/4-14 | Female NPT | 2 | 78.0 | (3.07) | 50.3 | (1.98) | 29.5 | (1.16) | 44.5 | (1.75) |
| 5111-12B | Complete | 3/4 | 3/4 | 3/4-14 | Female NPT | 3 | 132.3 | (5.21) | - | - | - | - | - | - |
| 5100-S2-16B | Male | 1 | 1 | 1-11 1/2 | Female NPT | 1 | 90.2 | (3.55) | 44.2 | (1.74) | 39.6 | (1.56) | - | - |
| 5110-S5-16B | Female | 1 | 1 | 1-11 1/2 | Female NPT | 2 | 93.5 | (3.68) | 61.2 | (2.41) | 36.6 | (1.44) | 53.8 | (2.12) |
| 5111-16B | Complete | 1 | 1 | 1-11 1/2 | Female NPT | 3 | 151.9 | (5.98) | - | - | - | - | - | - |
| 5100-S2-20B | Male | 1 1/4 | 1 1/4 | 1 1/4 - 11 1/2 | Female NPT | 1 | 94.2 | (3.71) | 52.8 | (2.08) | 47.8 | (1.88) | - | - |
| 5110-S5-20B | Female | 1 1/4 | 1 1/4 | 1 1/4 - 11 1/2 | Female NPT | 2 | 101.6 | (4.00) | 58.7 | (2.31) | 45.2 | (1.78) | 63.5 | (2.50) |
| 5111-20B | Complete | 1 1/4 | 1 1/4 | 1 1/4 - 11 1/2 | Female NPT | 3 | 160.3 | (6.31) | - | - | - | - | - | - |
| 5100-S2-24B | Male | 1 1/2 | 1 1/2 | 1 1/2 - 11 1/2 | Female NPT | 1 | 104.6 | (4.12) | 62.5 | (2.46) | 55.6 | (2.19) | 55.6 | (2.19) |
| 5110-S5-24B | Female | 1 1/2 | 1 1/2 | 1 1/2 - 11 1/2 | Female NPT | 2 | 104.1 | (4.10) | 78.7 | (3.10) | 50.8 | (2.00) | - | - |
| 5111-24B | Complete | 1 1/2 | 1 1/2 | 1 1/2 - 11 1/2 | Female NPT | 3 | 165.6 | (6.52) | - | - | - | - | - | - |

5100 Series

Thread to Connect

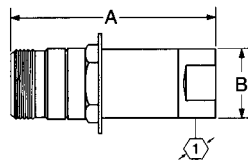

Figure 4

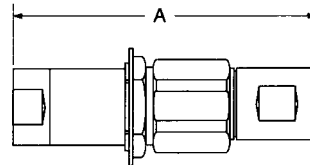

Figure 5

Dimensions (Female NPT, Valved WITH Flange)

| Part Number Buna-N | Coupling Type | Body Size | Port Size | Thread | Type | Fig. | Dimensions | | B | | Hex Ⓛ | |
|-----------------------|------------------|--------------|--------------|----------------|------------|------|------------|--------|------|--------|-------|--------|
| | | | | | | | A | | mm | (in) | mm | (in) |
| 5100-S4-4B | Male | 1/4 | 1/8 | 1/8-27 | Female NPT | 4 | 47.8 | (1.88) | 22.4 | (.88) | 23.3 | (.96) |
| 5110-4B | Complete | 1/4 | 1/8 | 1/8-27 | Female NPT | 5 | 81.3 | (3.20) | - | - | - | - |
| 5100-S4-6B | Male | 3/8 | 1/4 | 1/4-18 | Female NPT | 4 | 65.5 | (2.58) | 26.7 | (1.05) | 28.5 | (1.12) |
| 5110-6B | Complete | 3/8 | 1/4 | 1/4-18 | Female NPT | 5 | 104.4 | (4.11) | - | - | - | - |
| 5100-S4-8B | Male | 1/2 | 3/8 | 3/8-18 | Female NPT | 4 | 65.5 | (2.58) | 26.7 | (1.05) | 28.5 | (1.12) |
| 5110-8B | Complete | 1/2 | 3/8 | 3/8-18 | Female NPT | 5 | 104.4 | (4.11) | - | - | - | - |
| 5100-S4-10B | Male | 5/8 | 1/2 | 1/2-14 | Female NPT | 4 | 79.0 | (3.11) | 35.2 | (1.35) | 41.2 | (1.62) |
| 5110-10B | Complete | 5/8 | 1/2 | 1/2-14 | Female NPT | 5 | 132.3 | (5.21) | - | - | - | - |
| 5100-S4-12B | Male | 3/4 | 3/4 | 3/4-14 | Female NPT | 4 | 79.0 | (3.11) | 35.2 | (1.35) | 41.2 | (1.62) |
| 5110-12B | Complete | 3/4 | 3/4 | 3/4-14 | Female NPT | 5 | 132.3 | (5.21) | - | - | - | - |
| 5100-S4-16B | Male | 1 | 1 | 1-11 1/2 | Female NPT | 4 | 90.2 | (3.55) | 44.2 | (1.74) | 47.8 | (1.88) |
| 5110-16B | Complete | 1 | 1 | 1-11 1/2 | Female NPT | 5 | 151.9 | (5.98) | - | - | - | - |
| 5100-S4-20B | Male | 1 1/4 | 1 1/4 | 1 1/4 - 11 1/2 | Female NPT | 4 | 94.2 | (3.71) | 52.8 | (2.08) | 53.9 | (2.12) |
| 5110-20B | Complete | 1 1/4 | 1 1/4 | 1 1/4 - 11 1/2 | Female NPT | 5 | 160.3 | (6.31) | - | - | - | - |
| 5100-S4-24B | Male | 1 1/2 | 1 1/2 | 1 1/2 - 11 1/2 | Female NPT | 4 | 104.6 | (4.12) | 62.5 | (2.46) | 63.5 | (2.50) |
| 5110-24B | Complete | 1 1/2 | 1 1/2 | 1 1/2 - 11 1/2 | Female NPT | 5 | 165.6 | (6.52) | - | - | - | - |

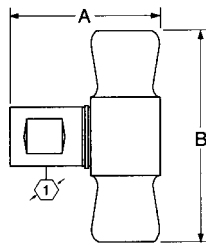

Figure 6

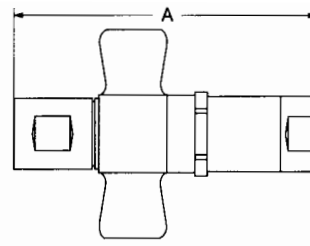

Figure 7

Dimensions (Female NPT, Valved WITH Wing Nut Less Flange)

| Part Number Buna-N | Coupling Type | Body Size | Port Size | Thread | Type | Fig. | Dimensions | | B | | Hex Ⓛ | |
|-----------------------|------------------|--------------|--------------|----------------|-------------|------|------------|--------|-------|--------|-------|--------|
| | | | | | | | A | | mm | (in) | mm | (in) |
| 5100-S5-4B | Female | 1/4 | 1/8 | 1/8-27 | Female NPT | 6 | 53.3 | (2.10) | 77.0 | (3.03) | 14.2 | (.56) |
| 5101-4B | Complete | 1/4 | 1/8 | 1/8-27 | Female NPT | 7 | 81.3 | (3.20) | - | - | - | - |
| 5100-S5-6B | Female | 3/8 | 1/4 | 1/4-18 | Female NPT | 6 | 61.0 | (2.40) | 87.4 | (3.44) | 19.3 | (.76) |
| 5101-6B | Complete | 3/8 | 1/4 | 1/4-18 | Female NPT | 7 | 104.4 | (4.11) | - | - | - | - |
| 5100-S5-8B | Female | 1/2 | 3/8 | 3/8-18 | Female NPT | 6 | 61.0 | (2.40) | 87.4 | (3.44) | 19.3 | (.76) |
| 5101-8B | Complete | 1/2 | 3/8 | 3/8-18 | Female NPT | 7 | 104.4 | (4.11) | - | - | - | - |
| 5100-S5-10B | Female | 5/8 | 1/2 | 1/2-14 | Female NPT | 6 | 78.0 | (3.07) | 104.9 | (4.13) | 29.5 | (1.16) |
| 5101-10B | Complete | 5/8 | 1/2 | 1/2-14 | Female NPT | 7 | 132.3 | (5.21) | - | - | - | - |
| 5100-S5-12B | Female | 3/4 | 3/4 | 3/4-14 | Female NPT | 6 | 78.0 | (3.07) | 104.9 | (4.13) | 29.5 | (1.16) |
| 5101-12B | Complete | 3/4 | 3/4 | 3/4-14 | Female NPT | 7 | 132.3 | (5.21) | - | - | - | - |
| 5100-S5-16B | Female | 1 | 1 | 1-11 1/2 | Female NPT | 6 | 93.5 | (3.68) | 111.3 | (4.38) | 36.6 | (1.44) |
| 5101-16B | Complete | 1 | 1 | 1-11 1/2 | Female NPT | 7 | 151.9 | (5.98) | - | - | - | - |
| 5100-S5-20B | Female | 1 1/4 | 1 1/4 | 1 1/4 - 11 1/2 | Female Pipe | 6 | 101.6 | (4.00) | 133.9 | (5.27) | 45.2 | (1.78) |
| 5101-20B | Complete | 1 1/4 | 1 1/4 | 1 1/4 - 11 1/2 | Female NPT | 7 | 160.3 | (6.31) | - | - | - | - |
| 5100-S5-24B | Female | 1 1/2 | 1 1/2 | 1 1/2 - 11 1/2 | Female NPT | 6 | 104.1 | (4.10) | 136.7 | (5.38) | 50.8 | (2.00) |
| 5101-24B | Complete | 1 1/2 | 1 1/2 | 1 1/2 - 11 1/2 | Female NPT | 7 | 165.6 | (6.52) | - | - | - | - |

Note: Uses the 5100-52 series male half shown on page 27.

5100 Series

Thread to Connect

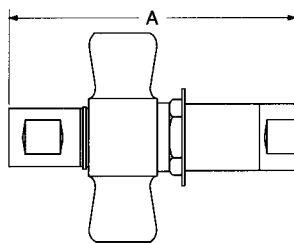

Figure 8

Dimensions (Female NPT, Valved WITH Wing Nut and Flange)

| Part Number Buna-N | Coupling Type | Body Size | Port Size | Thread | Type | Fig. A | Dimensions | |
|-----------------------|------------------|--------------|--------------|----------------|------------|--------|------------|--------|
| | | | | | | | mm | (in) |
| 5100-4B | Complete | 1/4 | 1/8 | 1/8-27 | Female NPT | 8 | 81.3 | (3.24) |
| 5100-6B | Complete | 3/8 | 1/4 | 1/4-18 | Female NPT | 8 | 104.4 | (4.11) |
| 5100-8B | Complete | 1/2 | 3/8 | 3/8-18 | Female NPT | 8 | 104.4 | (4.11) |
| 5100-10B | Complete | 5/8 | 1/2 | 1/2-14 | Female NPT | 8 | 132.3 | (5.21) |
| 5100-12B | Complete | 3/4 | 3/4 | 3/4-14 | Female NPT | 8 | 132.3 | (5.21) |
| 5100-16B | Complete | 1 | 1 | 1-11 1/2 | Female NPT | 8 | 151.9 | (5.89) |
| 5100-20B | Complete | 1 1/4 | 1 1/4 | 1 1/4 - 11 1/2 | Female NPT | 8 | 160.3 | (6.33) |
| 5100-24B | Complete | 1 1/2 | 1 1/2 | 1 1/2 - 11 1/2 | Female NPT | 8 | 165.6 | (6.54) |

Note: Uses the 5100-52 series male half shown on page 27.

Repair Kits

| Part Number Buna-N | Body Size |
|-----------------------|--------------|
| FF098-04 | 1/4 |
| FF098-08 | 3/8 & 1/2 |
| FF098-12 | 5/8 & 3/4 |
| FF082-16 | 1 |
| FF082-20 | 1 1/4 |
| FF082-24 | 1 1/2 |

Note: Each kit will repair both male and female halves.

Dust Caps and Dust Plugs

| Part Number Dust Cap with Chain | Dust Plug with Chain | Body Size |
|------------------------------------|----------------------|--------------|
| 5100-S7-5 | 5100-S9-5 | 1/4 |
| 5100-S7-8 | 5100-S9-8 | 3/8 & 1/2 |
| 5100-S7-12 | 5100-S9-12 | 5/8 & 3/4 |
| 5100-S7-16 | 5100-S9-16 | 1 |
| 5100-S7-20 | 5100-S9-20 | 1 1/4 |
| 5100-S7-24 | 5100-S9-24 | 1 1/2 |

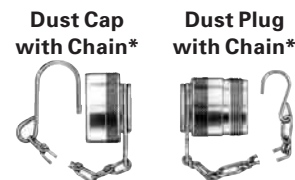

6-Bolt Flange Assembly

| Part Number 6-Bolt Flange Assembly | Body Size | Dimensions A | | B | |
|---------------------------------------|--------------|-----------------|--------|------|--------|
| | | mm | (in) | mm | (in) |
| 150-22-5 | 1/4 | 5.11 | (.201) | 33.6 | (1.44) |
| 150-22-8 | 3/8 & 1/2 | 5.11 | (.201) | 42.9 | (1.69) |
| 150-22-12 | 5/8 & 3/4 | 5.11 | (.201) | 53.8 | (2.12) |
| 150-22-16 | 1 | 5.11 | (.201) | 60.5 | (2.38) |
| 150-22-20 | 1 1/4 | 5.11 | (.201) | 66.5 | (2.62) |
| 5100-22-245 | 1 1/2 | 5.11 | (.201) | 82.6 | (3.25) |

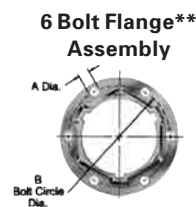

*To order caps and plugs without chain, order cap by part number 5100-32-(size) and plug by part number 5100-41-(size).

**6 Bolt Flange-holes equally spaced. (See "A" for bolt hole diameter, and "B" for bolt circle diameter).

5600 Series

ISO 7241/1

Series A Interchange



The 5600 Series general purpose industrial interchange coupling features a PUSH-PULL™ latch and poppet valving in a low profile design. The 5600 Series features a rugged ball latch mechanism with self-sealing poppet valves in a wide array of port configurations and multiple valved and non-valved configurations.

Product Features

- Meets dimensional requirements to ISO standard 7241/1 Series A
- PUSH-PULL™ ball latch design allows quick and easy connection and disconnection of fluid lines.
- Self-sealing poppet valve provides excellent high and low pressure sealing
- Streamlined valving provides minimum pressure drop
- Standard seal materials – Buna-N, EPR and Viton
- Standard body material – High resistance carbon steel with zinc trivalent plating (Brass poppet guide in -04 size)

Physical Characteristics

| Body Size | Max. Operating Pressure | | Min. Burst Pressure Connected | | Vacuum Connected Only | Rated Flow | | Air Inclusion | Fluid Loss |
|-----------|-------------------------|---------|-------------------------------|----------|-----------------------|------------|-------|---------------|------------|
| | bar | (psi) | bar | (psi) | (in./Hg) | L/min | (gpm) | cc. max. | cc.max. |
| 1/4 | 350 | (5,000) | 1,050 | (15,000) | 28 | 4 | (1) | 0.50 | 0.50 |
| 3/8 | 280 | (4,000) | 840 | (12,000) | 28 | 23 | (6) | 1.5 | 1.3 |
| 5/8 | 280 | (4,000) | 840 | (12,000) | 28 | 45 | (12) | 2.8 | 2.8 |
| 3/4 | 280 | (4,000) | 840 | (12,000) | 28 | 106 | (28) | 10.0 | 8.2 |
| 1 | 280 | (4,000) | 840 | (12,000) | 28 | 189 | (50) | 14.2 | 14.2 |



Applications

- Hydraulic fluid transfer
- Agricultural equipment
- Construction equipment
- Dump, snow plow and maintenance vehicles
- In-plant manufacturing



Flow Data

Pressure Drop Versus Flow Graph

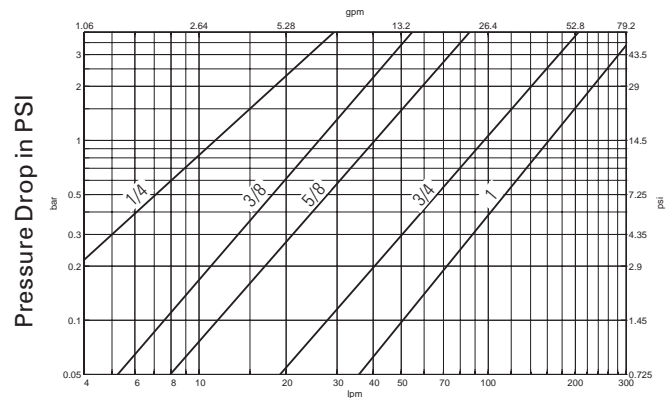

Gallons Per Minute Flow

Test Fluid: MIL-H-5606 Oil at 100°F

5600 Series

ISO 7241/1
Series A Interchange

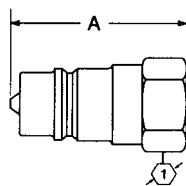

Figure 1

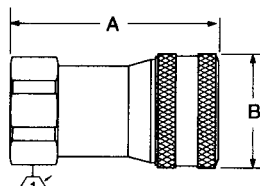

Figure 2

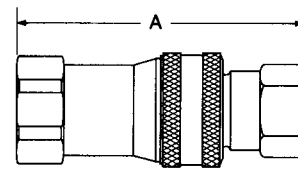

Figure 3

Dimensions (Female NPT, Valved)

| Part Number | Buna-N | Viton | EPR | Coupling Type | Body Size | Port Size | Thread | Type | Fig. | Dimensions | | | | | |
|-------------|-----------------|-------------|----------|---------------|-----------|-----------|------------|------|-------|------------|------|--------|------|--------|------|
| | | | | | | | | | | A | | B | | Hex ① | |
| | | | | | | | | | | mm | (in) | mm | (in) | mm | (in) |
| 5602-2-4S | FD56-1062-02-04 | 5644-2-4S | Male | 1/4 | 1/8 | 1/8-27 | Female NPT | 1 | 31.5 | (1.24) | - | - | 14.2 | (.56) | |
| 5601-2-4S | FD56-1064-02-04 | 5643-2-4S | Female | 1/4 | 1/8 | 1/8-27 | Female NPT | 2 | 46 | (1.81) | 27.4 | (1.08) | 22.4 | (.88) | |
| 5600-2-4S | FD56-1065-02-04 | 5642-2-4S | Complete | 1/4 | 1/8 | 1/8-27 | Female NPT | 3 | 61.5 | (2.42) | - | - | - | - | |
| 5602-4-4S | FD56-1062-04-04 | 5644-4-4S | Male | 1/4 | 1/4 | 1/4-18 | Female NPT | 1 | 33.3 | (1.31) | - | - | 19.1 | (.75) | |
| 5601-4-4S | FD56-1064-04-04 | 5643-4-4S | Female | 1/4 | 1/4 | 1/4-18 | Female NPT | 2 | 46 | (1.81) | 27.4 | (1.08) | 22.4 | (.88) | |
| 5600-4-4S | FD56-1065-04-04 | 5642-4-4S | Complete | 1/4 | 1/4 | 1/4-18 | Female NPT | 3 | 63.2 | (2.49) | - | - | - | - | |
| 5602-6-6S | FD56-1062-06-06 | 5644-6-6S | Male | 3/8 | 3/8 | 3/8-18 | Female NPT | 1 | 37.3 | (1.47) | - | - | 22.4 | (.88) | |
| 5601-6-6S | FD56-1064-06-06 | 5643-6-6S | Female | 3/8 | 3/8 | 3/8-18 | Female NPT | 2 | 54.6 | (2.15) | 31.2 | (1.23) | 25.4 | (1.00) | |
| 5600-6-6S | FD56-1065-06-06 | 5642-6-6S | Complete | 3/8 | 3/8 | 3/8-18 | Female NPT | 3 | 71.1 | (2.80) | - | - | - | - | |
| 5602-8-10S | FD56-1062-08-10 | 5644-8-10S | Male | 5/8 | 1/2 | 1/2-14 | Female NPT | 1 | 51.3 | (2.02) | - | - | 26.9 | (1.06) | |
| 5601-8-10S | FD56-1064-08-10 | 5643-8-10S | Female | 5/8 | 1/2 | 1/2-14 | Female NPT | 2 | 66.3 | (2.61) | 38.1 | (1.50) | 30.2 | (1.19) | |
| 5600-8-10S | FD56-1065-08-10 | 5642-8-10S | Complete | 5/8 | 1/2 | 1/2-14 | Female NPT | 3 | 96 | (3.78) | - | - | - | - | |
| 5602-12-10S | FD56-1062-12-10 | 5644-12-10S | Male | 5/8 | 3/4 | 3/4-14 | Female NPT | 1 | 54.9 | (2.16) | - | - | 35.1 | (1.38) | |
| 5601-12-10S | FD56-1064-12-10 | 5643-12-10S | Female | 5/8 | 3/4 | 3/4-14 | Female NPT | 2 | 66.3 | (2.61) | 38.1 | (1.50) | 33.3 | (1.31) | |
| 5600-12-10S | FD56-1065-12-10 | 5642-12-10S | Complete | 5/8 | 3/4 | 3/4-14 | Female NPT | 3 | 103.1 | (4.06) | - | - | - | - | |
| 5602-12-12S | FD56-1062-12-12 | 5644-12-12S | Male | 3/4 | 3/4 | 3/4-14 | Female NPT | 1 | 64.8 | (2.55) | - | - | 35.1 | (1.38) | |
| 5601-12-12S | FD56-1064-12-12 | 5643-12-12S | Female | 3/4 | 3/4 | 3/4-14 | Female NPT | 2 | 82.6 | (3.25) | 46 | (1.81) | 38.1 | (1.50) | |
| 5600-12-12S | FD56-1065-12-12 | 5642-12-12S | Complete | 3/4 | 3/4 | 3/4-14 | Female NPT | 3 | 115.8 | (4.56) | - | - | - | - | |
| 5602-16-16S | FD56-1062-16-16 | 5644-16-16S | Male | 1 | 1 | 1-11 1/2 | Female NPT | 1 | 78.7 | (3.10) | - | - | 41.1 | (1.62) | |
| 5601-16-16S | FD56-1064-16-16 | 5643-16-16S | Female | 1 | 1 | 1-11 1/2 | Female NPT | 2 | 97 | (3.82) | 53.3 | (2.10) | 42.9 | (1.69) | |
| 5600-16-16S | FD56-1065-16-16 | 5642-16-16S | Complete | 1 | 1 | 1-11 1/2 | Female NPT | 3 | 123.4 | (4.86) | - | - | - | - | |

Dimensions (Female NPT, Valved with Sleeve Lock)

| Part Number | Buna-N | Coupling Type | Body Size | Port Size | Thread | Type | Fig. | Dimensions | | | | | |
|-----------------|--------|---------------|-----------|-----------|----------|------------|------|------------|--------|------|--------|-------|--------|
| | | | | | | | | A | | B | | Hex ① | |
| | | | | | | | | mm | (in) | mm | (in) | mm | (in) |
| FD56-1239-08-10 | | Female | 5/8 | 1/2 | 1/2-14 | Female NPT | 2 | 66.3 | (2.61) | 38.1 | (1.50) | 30.2 | (1.19) |
| FD56-1239-12-12 | | Female | 3/4 | 3/4 | 3/4-14 | Female NPT | 2 | 82.6 | (3.25) | 46.7 | (1.84) | 38.1 | (1.50) |
| FD56-1239-16-16 | | Female | 1 | 1 | 1-11 1/2 | Female NPT | 2 | 97.0 | (3.82) | 54.1 | (2.13) | 42.9 | (1.69) |

5600 Series

ISO 7241/1
Series A Interchange

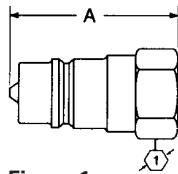

Figure 1

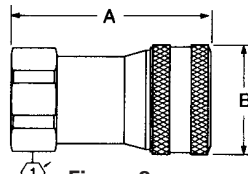

Figure 2

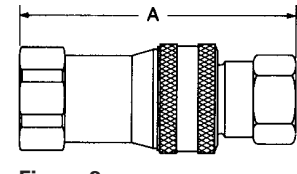

Figure 3

Dimensions (Female NPT, Non-Valved)

| Part Number | Buna-N | Viton | EPR | Coupling Type | Body Size | Port Size | Thread | Type | Fig. | Dimensions A | | Dimensions B | | Hex ① | |
|-----------------|-----------------|-----------------|-----------------|---------------|-----------|-----------|----------|------------|------|--------------|--------|--------------|--------|-------|--------|
| | | | | | | | | | | mm | (in) | mm | (in) | mm | (in) |
| FD56-1037-04-04 | FD56-1037-04-04 | FD56-1037-04-04 | FD56-1037-04-04 | Male | 1/4 | 1/4 | 1/4-18 | Female NPT | 1 | 31.5 | (1.24) | - | - | 19.1 | (.75) |
| FD56-1225-04-04 | FD56-1207-04-04 | FD56-1204-04-04 | FD56-1204-04-04 | Female | 1/4 | 1/4 | 1/4-18 | Female NPT | 2 | 46.0 | (1.81) | 27.4 | (1.08) | 22.4 | (.88) |
| FD56-1226-04-04 | FD56-1208-04-04 | FD56-1205-04-04 | FD56-1205-04-04 | Complete | 1/4 | 1/4 | 1/4-18 | Female NPT | 3 | 63.2 | (2.49) | - | - | - | - |
| FD56-1037-06-06 | FD56-1037-06-06 | FD56-1037-06-06 | FD56-1037-06-06 | Male | 3/8 | 3/8 | 3/8-18 | Female NPT | 1 | 35.6 | (1.40) | - | - | 22.4 | (.88) |
| FD56-1225-06-06 | FD56-1207-06-06 | FD56-1204-06-06 | FD56-1204-06-06 | Female | 3/8 | 3/8 | 3/8-18 | Female NPT | 2 | 54.6 | (2.15) | 31.2 | (1.23) | 25.4 | (1.00) |
| FD56-1226-06-06 | FD56-1208-06-06 | FD56-1205-06-06 | FD56-1205-06-06 | Complete | 3/8 | 3/8 | 3/8-18 | Female NPT | 3 | 71.1 | (2.80) | - | - | - | - |
| FD56-1037-08-10 | FD56-1037-08-10 | FD56-1037-08-10 | FD56-1037-08-10 | Male | 5/8 | 1/2 | 1/2-14 | Female NPT | 1 | 48 | (1.89) | - | - | 26.9 | (1.06) |
| FD56-1225-08-10 | FD56-1207-08-10 | FD56-1204-08-10 | FD56-1204-08-10 | Female | 5/8 | 1/2 | 1/2-14 | Female NPT | 2 | 66.3 | (2.61) | 38.1 | (1.50) | 30.2 | (1.19) |
| FD56-1226-08-10 | FD56-1208-08-10 | FD56-1205-08-10 | FD56-1205-08-10 | Complete | 5/8 | 1/2 | 1/2-14 | Female NPT | 3 | 96 | (3.78) | - | - | - | - |
| FD56-1225-12-12 | FD56-1207-12-12 | FD56-1204-12-12 | FD56-1204-12-12 | Female | 3/4 | 3/4 | 3/4-14 | Female NPT | 2 | 82.6 | (3.25) | 46.0 | (1.81) | 38.1 | (1.50) |
| FD56-1226-12-12 | FD56-1208-12-12 | FD56-1205-12-12 | FD56-1205-12-12 | Complete | 3/4 | 3/4 | 3/4-14 | Female NPT | 3 | 113.3 | (4.46) | - | - | - | - |
| FD56-1037-16-16 | FD56-1037-16-16 | FD56-1037-16-16 | FD56-1037-16-16 | Male | 1 | 1 | 1-11 1/2 | Female NPT | 1 | 70.4 | (2.77) | - | - | 41.1 | (1.62) |
| FD56-1225-16-16 | FD56-1207-16-16 | FD56-1204-16-16 | FD56-1204-16-16 | Female | 1 | 1 | 1-11 1/2 | Female NPT | 2 | 97 | (3.82) | 53.3 | (2.10) | 42.9 | (1.69) |
| FD56-1226-16-16 | FD56-1208-16-16 | FD56-1205-16-16 | FD56-1205-16-16 | Complete | 1 | 1 | 1-11 1/2 | Female NPT | 3 | 140.7 | (5.54) | - | - | - | - |

Note: Will not operate with valved coupling halves; no valve actuator. *Male halves contain no seals.

Dimensions (Female NPT, Pusher-Style Valving)

| Part Number | Buna-N | Viton | EPR | Coupling Type | Body Size | Port Size | Thread | Type | Fig. | Dimensions A | | Dimensions B | | Hex ① | |
|-----------------|-----------------|-----------------|-----------------|---------------|-----------|-----------|----------|------------|------|--------------|--------|--------------|--------|-------|--------|
| | | | | | | | | | | mm | (in) | mm | (in) | mm | (in) |
| FD56-1125-04-04 | FD56-1125-04-04 | FD56-1125-04-04 | FD56-1125-04-04 | Male | 1/4 | 1/4 | 1/4-18 | Female NPT | 1 | 31.5 | (1.24) | - | - | 19 | (.75) |
| FD56-1123-04-04 | FD56-1201-04-04 | FD56-1196-04-04 | FD56-1196-04-04 | Female | 1/4 | 1/4 | 1/4-18 | Female NPT | 2 | 46 | (1.81) | 27.4 | (1.08) | 22.4 | (.88) |
| FD56-1125-06-06 | FD56-1125-06-06 | FD56-1125-06-06 | FD56-1125-06-06 | Male | 3/8 | 3/8 | 3/8-18 | Female NPT | 1 | 35.6 | (1.40) | - | - | 22.4 | (.88) |
| FD56-1123-06-06 | FD56-1201-06-06 | FD56-1196-06-06 | FD56-1196-06-06 | Female | 3/8 | 3/8 | 3/8-18 | Female NPT | 2 | 54.6 | (2.15) | 31.2 | (1.23) | 25.4 | (1.00) |
| FD56-1125-08-10 | FD56-1125-08-10 | FD56-1125-08-10 | FD56-1125-08-10 | Male | 5/8 | 1/2 | 1/2-14 | Female NPT | 1 | 48 | (1.89) | - | - | 26.9 | (1.06) |
| FD56-1123-08-10 | FD56-1201-08-10 | FD56-1196-08-10 | FD56-1196-08-10 | Female | 5/8 | 1/2 | 1/2-14 | Female NPT | 2 | 66.3 | (2.61) | 38.1 | (1.50) | 30.2 | (1.19) |
| FD56-1125-12-12 | FD56-1125-12-12 | FD56-1125-12-12 | FD56-1125-12-12 | Male | 3/4 | 3/4 | 3/4-14 | Female NPT | 1 | 57.9 | (2.28) | - | - | 35.1 | (1.38) |
| FD56-1123-12-12 | FD56-1201-12-12 | FD56-1196-12-12 | FD56-1196-12-12 | Female | 3/4 | 3/4 | 3/4-14 | Female NPT | 2 | 82.6 | (3.25) | 46 | (1.81) | 38.1 | (1.50) |
| FD56-1125-16-16 | FD56-1125-16-16 | FD56-1125-16-16 | FD56-1125-16-16 | Male | 1 | 1 | 1-11 1/2 | Female NPT | 1 | 70.4 | (2.77) | - | - | 41.1 | (1.62) |
| FD56-1123-16-16 | FD56-1201-16-16 | FD56-1196-16-16 | FD56-1196-16-16 | Female | 1 | 1 | 1-11 1/2 | Female NPT | 2 | 97 | (3.82) | 53.3 | (2.10) | 42.9 | (1.69) |

Note: Incorporates a pusher device to open mating valved coupling halves.

Dimensions (Male Half, Female BSP/Valved)

| Part Number | Buna-N | Body Size | Thread | Fig. | Dimensions A | | Dimensions B | | Hex ① | |
|-------------|--------|-----------|--------|------|--------------|--------|--------------|------|-------|--------|
| | | | | | mm | (in) | mm | (in) | mm | (in) |
| G5623-4-4 | | 1/4 | G 1/4 | 1 | 1.25 | (31.8) | - | - | 0.75 | (19.0) |
| G5623-6-6 | | 3/8 | G 3/8 | 1 | 1.63 | (41.5) | - | - | 0.87 | (22.0) |
| G5623-8-10 | | 5/8 | G 1/2 | 1 | 1.88 | (47.7) | - | - | 1.06 | (27.0) |
| G5623-12-12 | | 3/4 | G 3/4 | 1 | 2.28 | (58.0) | - | - | 1.42 | (36.0) |
| G5623-16-16 | | 1 | G 1 | 1 | 2.76 | (70.0) | - | - | 1.61 | (41.0) |

5600 Series

ISO 7241/1
Series A Interchange

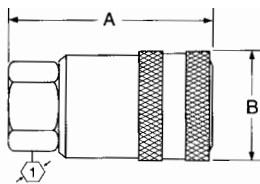

Figure 4

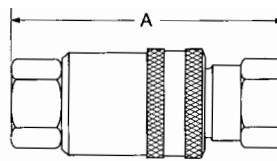

Figure 5

Dimensions (Female Half, Female BSP/Valved)

| Part Number Buna-N | Body Size | Thread | Fig. | Dimensions A | | B | | Hex ① | |
|-----------------------|-----------|--------|------|--------------|---------|------|--------|-------|--------|
| | | | | mm | (in) | mm | (in) | mm | (in) |
| G5622-4-4 | 1/4 | G 1/4 | 2 | 1.81 | (46.0) | 1.04 | (26.3) | 0.87 | (22.0) |
| G5622-6-6 | 3/8 | G 3/8 | 2 | 2.33 | (59.1) | 1.21 | (30.8) | 1.06 | (27.0) |
| G5622-8-10 | 5/8 | G 1/2 | 2 | 2.76 | (70.0) | 1.51 | (38.3) | 1.26 | (32.0) |
| G5622-12-12 | 3/4 | G 3/4 | 2 | 3.32 | (84.3) | 1.83 | (46.6) | 1.61 | (41.0) |
| G5622-16-16 | 1 | G 1 | 2 | 4.07 | (103.5) | 2.15 | (54.6) | 1.97 | (50.0) |

Dimensions (Female NPT, Connect Under Pressure Style)

| Part Number Buna-N | Viton | EPR | Type | Coupling Size | Body Size | Port Size | Thread | Type | Fig. | Dimensions | | | | Hex ① | |
|-----------------------|-----------------|---------------|----------|---------------|-----------|-----------|------------|--------|------|------------|--------|------|--------|-------|--------|
| | | | | | | | | | | A | B | | | mm | (in) |
| 5602-8-10S | FD56-1062-08-10 | 5644-8-10S | Male | 5/8 | 1/2 | 1/2-14 | Female NPT | Valved | 1 | 51.3 | (2.02) | - | - | 26.9 | (1.06) |
| 5651-8-10S | FD56-1070-08-10 | 565007-8-10S | Female | 5/8 | 1/2 | 1/2-14 | Female NPT | | 4 | 73.2 | (2.88) | 38.1 | (1.50) | 26.9 | (1.06) |
| 5650-8-10S | FD56-1071-08-10 | 565006-8-10S | Complete | 5/8 | 1/2 | 1/2-14 | Female NPT | | 5 | 98.8 | (3.89) | - | - | - | - |
| 5602-12-10S | FD56-1062-12-10 | 5644-12-10S | Male | 5/8 | 3/4 | 3/4-14 | Female NPT | Valved | 1 | 54.9 | (2.16) | - | - | 35.1 | (1.38) |
| 5651-12-10S | FD56-1070-12-10 | 565007-12-10S | Female | 5/8 | 3/4 | 3/4-14 | Female NPT | | 4 | 83.8 | (3.30) | 38.1 | (1.50) | 31.8 | (1.25) |
| 5650-12-10S | FD56-1071-12-10 | 565006-12-10S | Complete | 5/8 | 3/4 | 3/4-14 | Female NPT | | 5 | 113 | (4.45) | - | - | - | - |

Dimensions (Female, SAE O-ring Valved)

| Part Number Buna-N | Viton | EPR | Coupling Type | Body Size | Port Size | Thread | Type | Fig. | Dimensions | | | | Hex ① | |
|-----------------------|-----------------|------------------|---------------|-----------|-----------|-----------|-------------------|------|------------|--------|------|--------|-------|--------|
| | | | | | | | | | A | B | | | mm | (in) |
| 5610-4-4S | FD56-1072-04-04 | 560078-4-4S | Male | 1/4 | 7/16 | 7/16-20 | Female SAE O-ring | 1 | 32.5 | (1.28) | - | - | 15.7 | (.62) |
| 5608-4-4S | FD56-1074-04-04 | FD56-1012-04-04S | Female | 1/4 | 7/16 | 7/16-20 | Female SAE O-ring | 2 | 46 | (1.81) | 27.4 | (1.08) | 22.4 | (.88) |
| 5606-4-4S | FD56-1075-04-04 | FD56-1009-04-04S | Complete | 1/4 | 7/16 | 7/16-20 | Female SAE O-ring | 3 | 64.3 | (2.53) | - | - | - | - |
| 5610-6-6S | FD56-1072-06-06 | 560078-6-6S | Male | 3/8 | 9/16 | 9/16-18 | Female SAE O-ring | 1 | 38.1 | (1.50) | - | - | 22.4 | (.88) |
| 5608-6-6S | FD56-1074-06-06 | FD56-1012-06-06S | Female | 3/8 | 9/16 | 9/16-18 | Female SAE O-ring | 2 | 54.6 | (2.15) | 31.2 | (1.23) | 25.4 | (1.00) |
| 5606-6-6S | FD56-1075-06-06 | FD56-1009-06-06S | Complete | 3/8 | 9/16 | 9/16-18 | Female SAE O-ring | 3 | 72.1 | (2.84) | - | - | - | - |
| 5610-8-10S | FD56-1072-08-10 | 560078-8-10S | Male | 5/8 | 3/4 | 3/4-16 | Female SAE O-ring | 1 | 51.6 | (2.03) | - | - | 26.9 | (1.06) |
| 5608-8-10S | FD56-1074-08-10 | FD56-1012-08-10S | Female | 5/8 | 3/4 | 3/4-16 | Female SAE O-ring | 2 | 66.3 | (2.61) | 38.1 | (1.50) | 30.2 | (1.19) |
| 5606-8-10S | FD56-1075-08-10 | FD56-1009-08-10S | Complete | 5/8 | 3/4 | 3/4-16 | Female SAE O-ring | 3 | 96 | (3.78) | - | - | - | - |
| 5610-10-10S | FD56-1072-10-10 | 560078-10-10S | Male | 5/8 | 7/8 | 7/8-14 | Female SAE O-ring | 1 | 52.8 | (2.08) | - | - | 28.4 | (1.12) |
| 5608-10-10S | FD56-1074-10-10 | FD56-1012-10-10S | Female | 5/8 | 7/8 | 7/8-14 | Female SAE O-ring | 2 | 66.3 | (2.61) | 38.1 | (1.50) | 30.2 | (1.19) |
| 5606-10-10S | FD56-1075-10-10 | FD56-1009-10-10S | Complete | 5/8 | 7/8 | 7/8-14 | Female SAE O-ring | 3 | 98.6 | (3.88) | - | - | - | - |
| 5610-12-12S | FD56-1072-12-12 | 560078-12-12S | Male | 3/4 | 1 1/16 | 1 1/16-12 | Female SAE O-ring | 1 | 64.8 | (2.55) | - | - | 35.1 | (1.38) |
| 5608-12-12S | FD56-1074-12-12 | FD56-1012-12-12S | Female | 3/4 | 1 1/16 | 1 1/16-12 | Female SAE O-ring | 2 | 82.6 | (3.25) | 46 | (1.81) | 38.1 | (1.50) |
| 5606-12-12S | FD56-1075-12-12 | FD56-1009-12-12S | Complete | 3/4 | 1 1/16 | 1 1/16-12 | Female SAE O-ring | 3 | 115.8 | (4.56) | - | - | - | - |
| 5610-16-16S | FD56-1072-16-16 | 560078-16-16S | Male | 1 | 1 5/16 | 1 5/16-12 | Female SAE O-ring | 1 | 78.7 | (3.10) | - | - | 41.1 | (1.62) |
| 5608-16-16S | FD56-1074-16-16 | FD56-1012-16-16S | Female | 1 | 1 5/16 | 1 5/16-12 | Female SAE O-ring | 2 | 97.3 | (3.83) | 53.3 | (2.10) | 42.9 | (1.69) |
| 5606-16-16S | FD56-1075-16-16 | FD56-1009-16-16S | Complete | 1 | 1 5/16 | 1 5/16-12 | Female SAE O-ring | 3 | 140.7 | (5.54) | - | - | - | - |

Dimensions (Female SAE O-ring, Valved with Sleeve Lock)

| Part Number Buna-N | Viton | EPR | Coupling Type | Body Size | Port Size | Thread | Type | Fig. | Dimensions | | | | Hex ① | |
|-----------------------|-------|-----|---------------|-----------|-----------|-----------|-------------------|------|------------|--------|------|--------|-------|--------|
| | | | | | | | | | A | B | | | mm | (in) |
| FD56-1270-06-06 | - | - | Female | 3/8 | 9/16 | 9/16-18 | Female SAE O-ring | 3 | 54.6 | (2.15) | 31.8 | (1.23) | 25.4 | (1.00) |
| FD56-1270-08-10 | - | - | Female | 5/8 | 3/4 | 3/4-16 | Female SAE O-ring | 3 | 66.3 | (2.61) | 38.1 | (1.50) | 30.2 | (1.19) |
| FD56-1270-12-12 | - | - | Female | 3/4 | 1 1/16 | 1 1/16-12 | Female SAE O-ring | 3 | 82.6 | (3.25) | 46.7 | (1.81) | 38.1 | (1.50) |
| FD56-1270-16-16 | - | - | Female | 1 | 1 5/16 | 1 5/16-12 | Female SAE O-ring | 3 | 97.0 | (3.82) | 54.1 | (2.10) | 42.9 | (1.69) |

5600 Series

ISO 7241/1
Series A Interchange

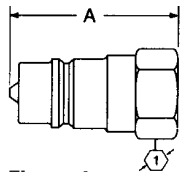

Figure 1

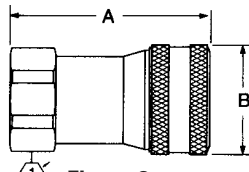

Figure 2

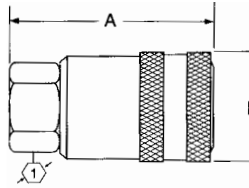

Figure 4

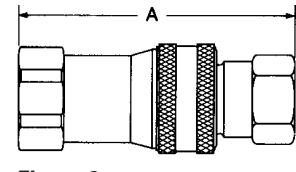

Figure 3

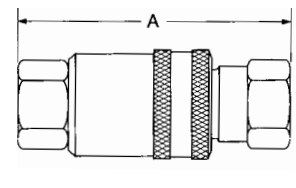

Figure 5

Dimensions (Female, SAE O-ring Non-Valved)

| Part Number | Buna-N | Viton | EPR | Coupling Type | Body Size | Port Size | Thread | Type | Fig. | Dimensions | | Hex | | | |
|-------------|-----------------|-----------------|----------|---------------|-----------|-----------|-------------------|------|-------|------------|------|--------|------|--------|------|
| | | | | | | | | | | A | B | | | | |
| | | | | | | | | | | mm | (in) | mm | (in) | mm | (in) |
| 5620-8-10S | FD56-1221-08-10 | FD56-1221-08-10 | Male | 5/8 | 3/4 | 3/4-16 | Female SAE O-ring | 1 | 48.0 | (1.89) | 25.9 | (1.02) | 26.9 | (1.06) | |
| 5691-8-10S | FD56-1233-08-10 | FD56-1209-08-10 | Female | 5/8 | 3/4 | 3/4-16 | Female SAE O-ring | 2 | 66.3 | (2.61) | 38.1 | (1.50) | 30.2 | (1.19) | |
| 5690-8-10S | FD56-1234-08-10 | FD56-1210-08-10 | Complete | 5/8 | 3/4 | 3/4-16 | Female SAE O-ring | 3 | 96.0 | (3.78) | - | - | - | - | |
| 5620-12-12S | FD56-1221-12-12 | FD56-1221-12-12 | Male | 3/4 | 1 1/16 | 1 1/16-12 | Female SAE O-ring | 1 | 57.9 | (2.28) | 30.7 | (1.21) | 35.1 | (1.38) | |
| 5691-12-12S | FD56-1233-12-12 | FD56-1209-12-12 | Female | 3/4 | 1 1/16 | 1 1/16-12 | Female SAE O-ring | 2 | 82.6 | (3.25) | 46.0 | (1.81) | 38.1 | (1.50) | |
| 5690-12-12S | FD56-1234-12-12 | FD56-1210-12-12 | Complete | 3/4 | 1 1/16 | 1 1/16-12 | Female SAE O-ring | 3 | 115.8 | (4.56) | - | - | - | - | |
| 5620-16-16S | FD56-1221-16-16 | FD56-1221-16-16 | Male | 1 | 1 5/16 | 1 5/16-12 | Female SAE O-ring | 1 | 70.4 | (2.77) | 36.8 | (1.45) | 41.1 | (1.62) | |
| 5691-16-16S | FD56-1233-16-16 | FD56-1209-16-16 | Female | 1 | 1 5/16 | 1 5/16-12 | Female SAE O-ring | 2 | 103.9 | (4.09) | 54.6 | (2.15) | 47.8 | (1.88) | |
| 5690-16-16S | FD56-1234-16-16 | FD56-1210-16-16 | Complete | 1 | 1 5/16 | 1 5/16-12 | Female SAE O-ring | 3 | 140.0 | (5.51) | - | - | - | - | |

Repair Kits

| Part Number | Viton | EPR | Body Size |
|-------------|-----------|-----------|-----------|
| FF082-04† | FF092-04† | FF093-04† | 1/4 |
| FF082-06 | FF092-06 | FF093-06 | 3/8 |
| FF082-10 | FF092-10 | FF093-10 | 5/8 |
| FF082-12 | FF092-12 | FF093-12 | 3/4 |
| FF082-16 | FF092-16 | FF093-16 | 1 |

Note: Each kit will repair one male or female half.

*The -02 coupling size valving is not repairable. This size repair kit contains an interface seal and back-up ring.

Break Away Frame

| Part Number | Body Size |
|-------------|-----------|
| 5603 | -10 |



Break Away Frame

Dust Caps

| Part Number | Body Size |
|-------------|-----------|
| 5654-4 | 1/4 |
| 5657-6 | 3/8 |
| 5657-10 | 5/8 |
| 5657-12 | 3/4 |
| 5657-16 | 1 |



Dust Cap

Dust Plugs

| Part Number | Body Size |
|-------------|-----------|
| 5659-4 | 1/4 |
| 5659-6 | 3/8 |
| 5659-10 | 5/8 |
| 5659-12 | 3/4 |
| 5659-16 | 1 |



Dust Plug

FD86 Series

Thread to Connect
5,000 psi Dry Break – High Impulse



The FD86 Series is a thread together steel quick coupling offering dry break and high impulse technology and capabilities. The maximum operating pressure is 5,000 psi. The FD86 Series is available in either wing nut or hex nut configurations for ease of assembly and disassembly. (For higher pressure applications and additional size requirements, refer to FD96 on page 42.)

Product Features

- Tubular valve and sleeve construction for low fluid loss and air inclusion
- Thread together design using wing or hex nut allows connection and disconnection against pressures up to 750 psi
- Teflon* back-up rings along with secondary metal-to-metal sealing contact provides high impulse capability up to 5,000 psi operating pressure
- Acme threads prevent galling and provide ease of connection
- Steel flange available for bulkhead mounting
- Standard seal material – Buna-N
- Standard body material – High resistance carbon steel with zinc trivalent plating

Physical Characteristics

| Body Size | Max. Operating Pressure | | Min. Burst Pressure | | Vacuum Connected Only | Rated Flow | | Air Inclusion | Fluid Loss |
|-----------|-------------------------|---------|---------------------|----------|-----------------------|------------|-------|---------------|------------|
| | bar | (psi) | bar | (psi) | (in./Hg) | L/min | (gpm) | cc. max. | cc.max. |
| 1 | 345 | (5,000) | 1,034 | (15,000) | 28 | 189 | (50) | 2.90 | 0.72 |
| 1/4 | 345 | (5,000) | 1,034 | (15,000) | 28 | 284 | (75) | 4.61 | 1.00 |



Applications

- Hydraulic and fluid transfer
- Mining equipment



Flow Data

Pressure Drop Versus Flow Graph

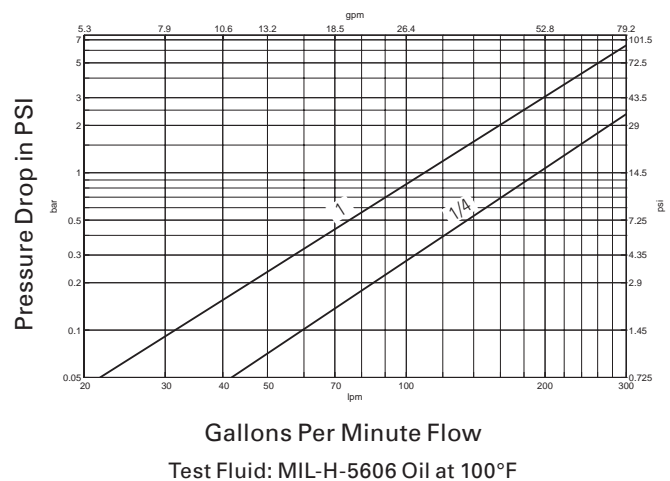

*Teflon is a registered trademark of Dupont.

FD86 Series

Thread to Connect
5,000 psi Dry Break – High Impulse

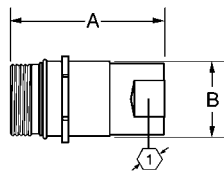

Figure 1

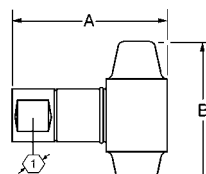

Figure 2

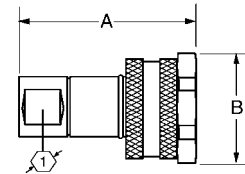

Figure 3

Dimensions (Female SAE O-ring)

| Part Number | Buna-N | Viton | EPR | Type | Body Size | Port Size | Thread | Type | Fig. | Dimensions | | Hex | | |
|-----------------|-----------------|-----------------|--------|-------|-----------|-------------|-------------------|------|-------|------------|-------|--------|------|--------|
| | | | | | | | | | | A | B | mm | (in) | mm |
| FD86-1008-16-16 | FD86-1043-16-16 | FD86-1053-16-16 | Male | 1 | 1 5/16 | 1 5/16 - 12 | Female SAE O-ring | 1 | 102.4 | (4.03) | 53.6 | (2.11) | 44.5 | (1.75) |
| FD86-1010-16-16 | FD86-1044-16-16 | FD86-1054-16-16 | Female | 1 | 1 5/16 | 1 5/16 - 12 | Female SAE O-ring | 2 | 117.3 | (4.62) | 114.3 | (4.50) | - | - |
| FD86-1006-16-16 | FD86-1042-16-16 | FD86-1052-16-16 | Female | 1 | 1 5/16 | 1 5/16 - 12 | Female SAE O-ring | 3 | 117.3 | (4.62) | 71.4 | (2.81) | 15.8 | (1.62) |
| FD86-1008-20-20 | FD86-1043-20-20 | FD86-1053-20-20 | Male | 1 1/4 | 1 5/8 | 1 5/8 - 12 | Female SAE O-ring | 1 | 105.7 | (4.16) | 63.0 | (2.48) | 57.2 | (2.25) |
| FD86-1010-20-20 | FD86-1044-20-20 | FD86-1054-20-20 | Female | 1 1/4 | 1 5/8 | 1 5/8 - 12 | Female SAE O-ring | 2 | 132.6 | (5.22) | 133.4 | (5.25) | - | - |
| FD86-1006-20-20 | FD86-1042-20-20 | FD86-1052-20-20 | Female | 1 1/4 | 1 5/8 | 1 5/8 - 12 | Female SAE O-ring | 3 | 132.6 | (5.22) | 86.4 | (3.40) | 50.8 | (2.00) |

Dimensions (Female NPT)

| Part Number | Buna-N | Viton | EPR | Type | Body Size | Port Size | Thread | Type | Fig. | Dimensions | | Hex | | |
|-----------------|-----------------|-----------------|--------|-------|----------------|----------------|------------|------|-------|------------|-------|--------|------|--------|
| | | | | | | | | | | A | B | mm | (in) | mm |
| FD86-1002-16-16 | FD86-1040-16-16 | FD86-1050-16-16 | Male | 1 | 1 - 11 1/2 | 1 - 11 1/2 | Female NPT | 1 | 111.8 | (4.40) | 53.6 | (2.11) | 44.5 | (1.75) |
| FD86-1001-16-16 | FD86-1039-16-16 | FD86-1049-16-16 | Female | 1 | 1 - 11 1/2 | 1 - 11 1/2 | Female NPT | 2 | 126.5 | (4.98) | 114.3 | (4.50) | - | - |
| FD86-1004-16-16 | FD86-1041-16-16 | FD86-1051-16-16 | Female | 1 | 1 - 11 1/2 | 1 - 11 1/2 | Female NPT | 3 | 126.5 | (4.98) | 71.4 | (2.81) | 15.8 | (1.62) |
| FD86-1002-20-20 | FD86-1040-20-20 | FD86-1050-20-20 | Male | 1 1/4 | 1 1/4 - 11 1/2 | 1 1/4 - 11 1/2 | Female NPT | 1 | 112.5 | (4.43) | 63.0 | (2.48) | 57.2 | (2.25) |
| FD86-1001-20-20 | FD86-1039-20-20 | FD86-1049-20-20 | Female | 1 1/4 | 1 1/4 - 11 1/2 | 1 1/4 - 11 1/2 | Female NPT | 2 | 142.8 | (5.62) | 133.4 | (5.25) | - | - |
| FD86-1004-20-20 | FD86-1041-20-20 | FD86-1051-20-20 | Female | 1 1/4 | 1 1/4 - 11 1/2 | 1 1/4 - 11 1/2 | Female NPT | 3 | 142.8 | (5.62) | 86.4 | (3.40) | 50.8 | (2.00) |

Repair Kits

| Part Number | Buna-N | Viton | EPR | Body Size | Coupling Type |
|-------------|------------|------------|-------|-----------|---------------|
| FF10596-16 | FF10597-16 | FF10598-16 | 1 | Male | |
| FF10593-16 | FF10594-16 | FF10595-16 | 1 | Female | |
| FF10596-20 | FF10597-20 | FF10598-20 | 1 1/4 | Male | |
| FF10593-20 | FF10594-20 | FF10595-20 | 1 1/4 | Female | |

Dust Caps and Dust Plugs

| Part Number | Dust Cap with Chain | Dust Plug with Chain | Body Size |
|--------------|---------------------|----------------------|-----------|
| FD86-1018-16 | FD86-1016-16 | 1 | |
| FD86-1018-20 | FD86-1016-20 | 1 1/4 | |

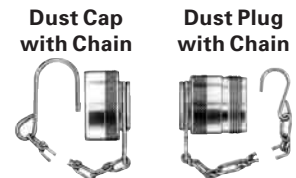

FD89 Series

ISO 16028 Interchange



Eaton's FD89 Series flush face is specifically designed for those applications where quick and easy connections and no-spill performance are essential. The FD89 is ideal for use where global interchangeability with other manufacturers is important and is available in sizes from 1/4" through 2" to best meet your specific size requirements. (For higher pressure applications and additional size requirements, refer to FD99 on page 44.)

Product Features

- Meets dimensional requirements of ISO 16028
- Push-to-connect latching
- Dual flush-face valving
- Anti-extrusion Teflon seal
- Safety sleeve lock
- Interchangeable with HTMA couplings (3/8")
- Standard seal material – Buna-N
- Standard body material – High resistance carbon steel with zinc trivalent plating

Physical Characteristics

| ISO Size (mm) | Body Size | Max. Operating Pressure | | | Min. Burst Pressure | | | Rated Flow L/min (gpm) | Fluid Loss cc. | Air Inclusion cc. | Force to Connect N (lbs) |
|---------------|-----------|-------------------------|---------------------|-----------------------|---------------------|---------------------|-----------------------|------------------------|----------------|-------------------|--------------------------|
| | | Connected bar (psi) | Male Half bar (psi) | Female Half bar (psi) | Connected bar (psi) | Male Half bar (psi) | Female Half bar (psi) | | | | |
| 6.3 | 1/4 | 300 (4,350) | 300 (4,350) | 120 (1,740) | 1,200 (17,400) | 1,200 (17,400) | 480 (6,960) | 12 (3.2) | 0.006 | 0.005 | 179 (40.2) |
| 10.0 | 3/8 | 300 (4,350) | 300 (4,350) | 120 (1,740) | 1,200 (17,400) | 1,200 (17,400) | 480 (6,960) | 23 (6.1) | 0.012 | 0.280 | 173 (38.9) |
| 12.5 | 1/2 | 250 (3,625) | 250 (3,625) | 100 (1,450) | 1,000 (14,500) | 1,000 (14,500) | 400 (5,800) | 45 (11.9) | 0.020 | 0.040 | 181 (40.7) |
| 16.0 | 3/4 | 250 (3,625) | 220 (3,190) | 100 (1,450) | 1,000 (14,500) | 880 (12,760) | 400 (5,800) | 74 (19.5) | 0.026 | 0.270 | 195 (43.8) |
| 19.0 | 1 | 250 (3,625) | 200 (2,900) | 100 (1,450) | 1,000 (14,500) | 800 (11,600) | 400 (5,800) | 100 (26.4) | 0.032 | 0.040 | 224 (50.4) |
| 25.0 | 1 1/4 | 250 (3,625) | 200 (2,900) | 100 (1,450) | 1,000 (14,500) | 800 (11,600) | 400 (5,800) | 189 (49.9) | 0.010 | 0.140 | 304 (68.3) |
| 31.5 | 1 1/2 | 200 (2,900) | 160 (2,320) | 80 (1,160) | 800 (11,600) | 640 (9,280) | 320 (4,640) | 288 (76.1) | 0.050 | 0.980 | 427 (96.0) |
| 40.0 | 2 | 200 (2,900) | 160 (2,320) | 80 (1,160) | 800 (11,600) | 640 (9,280) | 320 (4,640) | 379 (100.0) | N/A | N/A | 488 (110.0) |



Applications

- Hydraulic and fluid transfer
- Construction equipment
- Agricultural equipment
- Utility vehicles
- On-highway vehicles
- Stationary in-plant hydraulics and fluid transfer
- Interchangeable with HTMA couplings (3/8")

Flow Data

Pressure Drop Versus Flow Graph

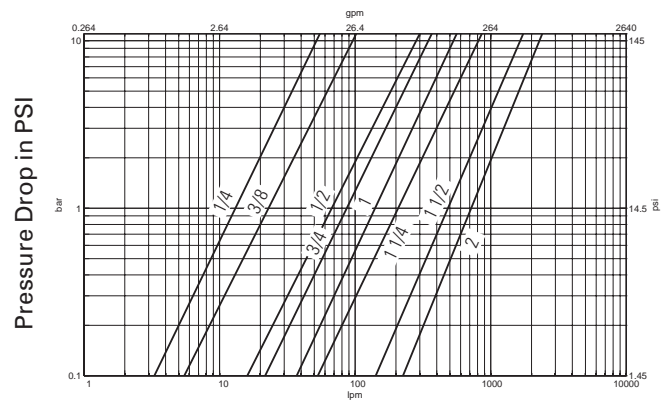

Gallons Per Minute Flow

Test Fluid: MIL-H-5606 Oil at 100°F

FD89 Series

ISO 16028 Interchange

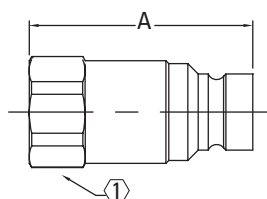

Figure 1

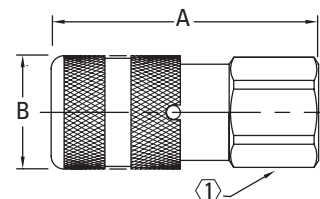

Figure 2

Dimensions (Female NPT)

| Part Number | Coupling Type | Body Size | Port Size | Thread | Type | Fig. | Dimensions | | | | | |
|-----------------|---------------|-----------|-----------|----------------|------------|------|------------|--------|-------|--------|-------|--------|
| | | | | | | | A | | B | | Hex ① | |
| | | | | | | | mm | (in) | mm | (in) | mm | (in) |
| FD89-1001-04-04 | Female | 1/4 | 1/4 | 1/4 - 18 | Female NPT | 2 | 48.1 | (1.89) | 28.0 | (1.10) | 22 | (0.86) |
| FD89-1002-04-04 | Male | 1/4 | 1/4 | 1/4 - 18 | Female NPT | 1 | 47.9 | (1.88) | | | 22 | (0.86) |
| FD89-1001-06-06 | Female | 3/8 | 3/8 | 3/8 - 18 | Female NPT | 2 | 64.2 | (2.53) | 32.0 | (1.26) | 27 | (1.06) |
| FD89-1002-06-06 | Male | 3/8 | 3/8 | 3/8 - 18 | Female NPT | 1 | 60.0 | (2.36) | | | 24 | (0.94) |
| FD89-1001-08-06 | Female | 3/8 | 1/2 | 1/2 - 14 | Female NPT | 2 | 69.2 | (2.72) | 32.0 | (1.26) | 27 | (1.06) |
| FD89-1002-08-06 | Male | 3/8 | 1/2 | 1/2 - 14 | Female NPT | 1 | 62.5 | (2.46) | | | 27 | (1.06) |
| FD89-1001-08-08 | Female | 1/2 | 1/2 | 1/2 - 14 | Female NPT | 2 | 73.8 | (2.91) | 38.0 | (1.49) | 32 | (1.26) |
| FD89-1002-08-08 | Male | 1/2 | 1/2 | 1/2 - 14 | Female NPT | 1 | 68.0 | (2.67) | | | 32 | (1.26) |
| FD89-1001-12-08 | Female | 1/2 | 3/4 | 3/4 - 14 | Female NPT | 2 | 80.8 | (3.18) | 38.0 | (1.49) | 36 | (1.42) |
| FD89-1002-12-08 | Male | 1/2 | 3/4 | 3/4 - 14 | Female NPT | 1 | 70.5 | (2.78) | | | 36 | (1.42) |
| FD89-1001-12-10 | Female | 3/4 | 3/4 | 3/4 - 14 | Female NPT | 2 | 78.5 | (3.09) | 42.0 | (1.65) | 36 | (1.42) |
| FD89-1002-12-10 | Male | 3/4 | 3/4 | 3/4 - 14 | Female NPT | 1 | 70.5 | (2.78) | | | 36 | (1.42) |
| FD89-1001-16-12 | Female | 1 | 1 | 1 - 11 1/2 | Female NPT | 2 | 93.2 | (3.67) | 48.0 | (1.89) | 45 | (1.77) |
| FD89-1002-16-12 | Male | 1 | 1 | 1 - 11 1/2 | Female NPT | 1 | 82.3 | (3.24) | | | 45 | (1.77) |
| FD89-1001-20-16 | Female | 1 1/4 | 1 1/4 | 1 1/4 - 11 1/2 | Female NPT | 2 | 106.0 | (4.17) | 55.0 | (2.17) | 55 | (2.17) |
| FD89-1002-20-16 | Male | 1 1/4 | 1 1/4 | 1 1/4 - 11 1/2 | Female NPT | 1 | 89.8 | (3.54) | | | 55 | (2.17) |
| FD89-1001-24-24 | Female | 1 1/2 | 1 1/2 | 1 1/2 - 11 1/2 | Female NPT | 2 | 132.4 | (5.21) | 80.0 | (3.15) | 65 | (2.56) |
| FD89-1002-24-24 | Male | 1 1/2 | 2 | 1 1/2 - 11 1/2 | Female NPT | 1 | 111.1 | (4.37) | | | 65 | (2.56) |
| FD89-1001-32-32 | Female | 2 | 2 | 2 - 11 1/2 | Female NPT | 2 | 156.6 | (6.17) | 100.0 | (3.94) | 80 | (3.15) |
| FD89-1002-32-32 | Male | 2 | 2 | 2 - 11 1/2 | Female NPT | 1 | 123.8 | (4.87) | | | 75 | (2.95) |

Dimensions (Female BSP)

| Part Number | Coupling Type | Body Size | Port Size | Thread | Type | Fig. | Dimensions | | | | | |
|-----------------|---------------|-----------|-----------|---------|------------|------|------------|--------|-------|--------|-------|--------|
| | | | | | | | A | | B | | Hex ① | |
| | | | | | | | mm | (in) | mm | (in) | mm | (in) |
| FD89-1006-04-04 | Female | 1/4 | 1/4 | G 1/4 | Female BSP | 2 | 48.1 | (1.89) | 28.0 | (1.10) | 22 | (0.86) |
| FD89-1007-04-04 | Male | 1/4 | 1/4 | G 1/4 | Female BSP | 1 | 47.9 | (1.88) | | | 22 | (0.86) |
| FD89-1006-06-06 | Female | 3/8 | 3/8 | G 3/8 | Female BSP | 2 | 64.2 | (2.53) | 32.0 | (1.26) | 27 | (1.06) |
| FD89-1007-06-06 | Male | 3/8 | 3/8 | G 3/8 | Female BSP | 1 | 60.0 | (2.36) | | | 24 | (0.94) |
| FD89-1006-08-06 | Female | 3/8 | 1/2 | G 1/2 | Female BSP | 2 | 69.2 | (2.72) | 32.0 | (1.26) | 27 | (1.06) |
| FD89-1007-08-06 | Male | 3/8 | 1/2 | G 1/2 | Female BSP | 1 | 62.5 | (2.46) | | | 27 | (1.06) |
| FD89-1006-08-08 | Female | 1/2 | 1/2 | G 1/2 | Female BSP | 2 | 73.8 | (2.91) | 38.0 | (1.49) | 32 | (1.26) |
| FD89-1007-08-08 | Male | 1/2 | 1/2 | G 1/2 | Female BSP | 1 | 68.0 | (2.67) | | | 32 | (1.26) |
| FD89-1006-12-08 | Female | 1/2 | 3/4 | G 3/4 | Female BSP | 2 | 80.8 | (3.18) | 38.0 | (1.49) | 36 | (1.42) |
| FD89-1007-12-08 | Male | 1/2 | 3/4 | G 3/4 | Female BSP | 1 | 70.5 | (2.78) | | | 36 | (1.42) |
| FD89-1006-12-10 | Female | 3/4 | 3/4 | G 3/4 | Female BSP | 2 | 78.5 | (3.09) | 42.0 | (1.65) | 36 | (1.42) |
| FD89-1007-12-10 | Male | 3/4 | 3/4 | G 3/4 | Female BSP | 1 | 70.5 | (2.78) | | | 36 | (1.42) |
| FD89-1006-16-12 | Female | 1 | 1 | G 1 | Female BSP | 2 | 93.2 | (3.67) | 48.0 | (1.89) | 45 | (1.77) |
| FD89-1007-16-12 | Male | 1 | 1 | G 1 | Female BSP | 1 | 82.3 | (3.24) | | | 45 | (1.77) |
| FD89-1006-20-16 | Female | 1 1/4 | 1 1/4 | G 1 1/4 | Female BSP | 2 | 106.0 | (4.17) | 55.0 | (2.17) | 55 | (2.17) |
| FD89-1007-20-16 | Male | 1 1/4 | 1 1/4 | G 1 1/4 | Female BSP | 1 | 89.9 | (3.54) | | | 55 | (2.17) |
| FD89-1006-24-24 | Female | 1 1/2 | 1 1/2 | G 1 1/2 | Female BSP | 2 | 132.4 | (5.21) | 80.0 | (3.15) | 65 | (2.56) |
| FD89-1007-24-24 | Male | 1 1/2 | 1 1/2 | G 1 1/2 | Female BSP | 1 | 111.1 | (4.37) | | | 65 | (2.56) |
| FD89-1006-32-32 | Female | 2 | 2 | G 2 | Female BSP | 2 | 156.6 | (6.17) | 100.0 | (3.94) | 80 | (3.15) |
| FD89-1007-32-32 | Male | 2 | 2 | G 2 | Female BSP | 1 | 123.8 | (4.87) | | | 75 | (2.95) |

FD89 Series

ISO 16028 Interchange

Dimensions (Female SAE O-ring)

| Part Number | Coupling Type | Body Size | Port Size | Thread | Type | Fig. | Dimensions | | | | | |
|-----------------|---------------|-----------|-----------|----------------|-------------------|------|------------|--------|-------|--------|-------|--------|
| | | | | | | | A | | B | | Hex ① | |
| | | | | | | | mm | (in) | mm | (in) | mm | (in) |
| FD89-1005-06-04 | Female | 1/4 | 9/16 | 9/16 - 18 UNF | Female SAE O-ring | 2 | 53.1 | (2.09) | 28.0 | (1.10) | 22 | (0.86) |
| FD89-1004-06-04 | Male | 1/4 | 9/16 | 9/16 - 18 UNF | Female SAE O-ring | 1 | 50.9 | (2.00) | | | 22 | (0.86) |
| FD89-1005-08-06 | Female | 3/8 | 3/4 | 3/4 - 16 UNF | Female SAE O-ring | 2 | 69.2 | (2.72) | 32.0 | (1.26) | 27 | (1.06) |
| FD89-1004-08-06 | Male | 3/8 | 3/4 | 3/4 - 16 UNF | Female SAE O-ring | 1 | 62.5 | (2.46) | | | 27 | (1.06) |
| FD89-1005-10-06 | Female | 3/8 | 7/8 | 7/8 - 14 UNF | Female SAE O-ring | 2 | 71.2 | (2.80) | 32.0 | (1.26) | 30 | (1.18) |
| FD89-1004-10-06 | Male | 3/8 | 7/8 | 7/8 - 14 UNF | Female SAE O-ring | 1 | 64.0 | (2.52) | | | 30 | (1.18) |
| FD89-1005-10-08 | Female | 1/2 | 7/8 | 7/8 - 14 UNF | Female SAE O-ring | 2 | 76.3 | (3.00) | 38.0 | (1.49) | 32 | (1.26) |
| FD89-1004-10-08 | Male | 1/2 | 7/8 | 7/8 - 14 UNF | Female SAE O-ring | 1 | 70.0 | (2.76) | | | 32 | (1.26) |
| FD89-1005-12-08 | Female | 1/2 | 1 1/16 | 1 1/16 - 12 UN | Female SAE O-ring | 2 | 83.3 | (3.28) | 38.0 | (1.49) | 36 | (1.42) |
| FD89-1004-12-08 | Male | 1/2 | 1 1/16 | 1 1/16 - 12 UN | Female SAE O-ring | 1 | 72.0 | (2.83) | | | 36 | (1.42) |
| FD89-1005-12-10 | Female | 3/4 | 1 1/16 | 1 1/16 - 12 UN | Female SAE O-ring | 2 | 83.5 | (3.29) | 42.0 | (1.65) | 36 | (1.42) |
| FD89-1004-12-10 | Male | 3/4 | 1 1/16 | 1 1/16 - 12 UN | Female SAE O-ring | 1 | 72.0 | (2.83) | | | 36 | (1.42) |
| FD89-1005-16-12 | Female | 1 | 1 5/16 | 1 5/16 - 12 UN | Female SAE O-ring | 2 | 93.2 | (3.67) | 48.0 | (1.89) | 45 | (1.77) |
| FD89-1004-16-12 | Male | 1 | 1 5/16 | 1 5/16 - 12 UN | Female SAE O-ring | 1 | 82.3 | (3.24) | | | 45 | (1.77) |
| FD89-1005-20-16 | Female | 1 1/4 | 1 5/8 | 1 5/8 - 12 UN | Female SAE O-ring | 2 | 106.0 | (4.17) | 55.0 | (2.17) | 55 | (2.17) |
| FD89-1004-20-16 | Male | 1 1/4 | 1 5/8 | 1 5/8 - 12 UN | Female SAE O-ring | 1 | 89.8 | (3.54) | | | 55 | (2.17) |
| FD89-1005-24-24 | Female | 1 1/2 | 1 7/8 | 1 7/8 - 12 UN | Female SAE O-ring | 2 | 132.4 | (5.21) | 80.0 | (3.15) | 65 | (2.56) |
| FD89-1004-24-24 | Male | 1 1/2 | 2 | 1 7/8 - 12 UN | Female SAE O-ring | 1 | 111.1 | (4.37) | | | 65 | (2.56) |
| FD89-1005-32-32 | Female | 2 | 2 1/2 | 2 1/2 - 12 UN | Female SAE O-ring | 2 | 156.6 | (6.17) | 100.0 | (3.94) | 80 | (3.15) |
| FD89-1004-32-32 | Male | 2 | 2 1/2 | 2 1/2 - 12 UN | Female SAE O-ring | 1 | 123.8 | (4.87) | | | 75 | (2.95) |

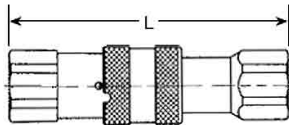

Dimensions — Connected Length

| Body Size | Dimensions NPT & BSP | | SAE O-ring | |
|-----------|----------------------|--------|------------|--------|
| | mm | (in) | mm | (in) |
| 1/4 | 85.5 | (3.37) | - | - |
| 3/8 - 1/4 | - | - | 93.2 | (3.67) |
| 3/8 - 3/8 | 109.0 | (4.29) | - | - |
| 1/2 - 3/8 | 116.5 | (4.59) | 116.2 | (4.57) |
| 1/2 - 1/2 | 125.0 | (4.92) | - | - |
| 5/8 - 3/8 | - | - | 119.7 | (4.71) |
| 5/8 - 1/2 | - | - | 129.1 | (5.08) |
| 3/4 - 1/2 | 134.5 | (5.30) | 138.1 | (5.44) |
| 3/4 | 132.0 | (5.2) | 138.0 | (5.43) |
| 1 | 154.0 | (6.06) | 153.7 | (6.05) |
| 1 1/4 | 173.0 | (6.81) | 172.8 | (6.80) |
| 1 1/2 | 215.0 | (8.46) | 215.2 | (8.47) |
| 2 | 241.5 | (9.51) | 241.6 | (9.51) |

Female Half Dust Caps

| Part Number | Coupling Type | Body Size | Cap Material |
|-----------------|---------------|-----------|--------------|
| FD89-1009-04 | Female | 1/4 | PVC |
| FD89-1009-06 | Female | 3/8 | PVC |
| FD89-1009-08-08 | Female | 1/2, 1/2 | PVC |
| FD89-1009-12-08 | Female | 3/4, 1/2 | PVC |
| FD89-1009-12 | Female | 3/4 | PVC |
| FD89-1009-16 | Female | 1 | PVC |
| FD89-1009-20 | Female | 1 1/4 | PVC |

Male Half Dust Cap

| Part Number | Coupling Type | Body Size | Cap Material |
|-----------------|---------------|-----------|--------------|
| FD89-1008-04 | Male | 1/4 | PVC |
| FD89-1008-06-06 | Male | 3/8, 3/8 | PVC |
| FD89-1008-08-06 | Male | 1/2, 3/8 | PVC |
| FD89-1008-08-08 | Male | 1/2, 1/2 | PVC |
| FD89-1008-12-08 | Male | 3/4, 1/2 | PVC |
| FD89-1008-12 | Male | 3/4 | PVC |
| FD89-1008-16 | Male | 1 | PVC |
| FD89-1008-20 | Male | 1 1/4 | PVC |

FD89 - 2000 Series

316 Stainless Steel
ISO 16028 Interchange



The FD89 Stainless Steel Series is designed for those applications where quick and easy connections and non-spill performance are critical. Ideal for use where global interchangeability with other manufactures is important. The 316 stainless steel material is suitable for applications where high corrosion resistance and long product life is essential. The FD89 2000 Series is available in sizes 1/4" through 2" to best meet your specific size requirements.

Product Features

- Meets dimensional requirements of ISO 16028
- Push-to-connect latching
- Dual flush-face valving with non-spill design
- Safety sleeve lock
- Anti-extrusion Teflon® seal
- Body material – 316 stainless steel
- Standard seal material – Viton, other material available on request

Physical Characteristics

| ISO Size | Body Size | Max. Operating Pressure | | | Min. Burst Pressure | | | Rated Flow | Fluid Loss | Force to Connect |
|----------|-----------|-------------------------|-------------|-------------|---------------------|----------------|-------------|-------------|------------|------------------|
| | | Connected | Male Half | Female Half | Connected | Male Half | Female Half | | | |
| | | bar (psi) | bar (psi) | bar (psi) | bar (psi) | bar (psi) | bar (psi) | L/min (gpm) | cc. | N (lbs.) |
| 6.3 | 1/4 | 350 (5,075) | 350 (5,075) | 120 (1,740) | 1,400 (20,300) | 1,200 (17,400) | 480 (6,960) | 12 (3.2) | .006 | 160 (36) |
| 10.0 | 3/8 | 350 (5,075) | 350 (5,075) | 150 (2,175) | 1,400 (20,300) | 1,200 (17,400) | 600 (8,700) | 23 (6.1) | .012 | 160 (36) |
| 12.5 | 1/2 | 350 (5,075) | 350 (5,075) | 150 (2,175) | 1,200 (17,400) | 1,100 (15,950) | 600 (8,700) | 45 (11.9) | .020 | 200 (45) |
| 16.0 | 5/8 | 350 (5,075) | 300 (4,350) | 120 (1,740) | 1,200 (17,400) | 1,000 (14,500) | 480 (6,960) | 74 (19.6) | .026 | 200 (45) |
| 19.0 | 3/4 | 330 (4,785) | 230 (4,060) | 120 (1,740) | 1,000 (14,500) | 800 (11,600) | 480 (6,960) | 100 (26.5) | .032 | 200 (45) |
| 25.0 | 1 | 280 (4,060) | 280 (4,060) | 120 (1,740) | 900 (13,050) | 800 (11,600) | 480 (6,960) | 189 (50.1) | .035 | 280 (63) |
| 31.5 | 1 1/4 | 230 (3,335) | 230 (3,335) | 80 (1,160) | 800 (11,600) | 700 (10,150) | 320 (4,640) | 288 (76.3) | .050 | 580 (131) |
| 40.0 | 2 | 150 (2,175) | 150 (2,175) | 70 (1,015) | 600 (8,700) | 600 (8,700) | 280 (4,060) | 379 (100.5) | .100 | 490 (110) |



Applications

- Hydraulic fluid transfer
- Chemical processing
- Pharmaceutical transfer
- Oil field

Flow Data

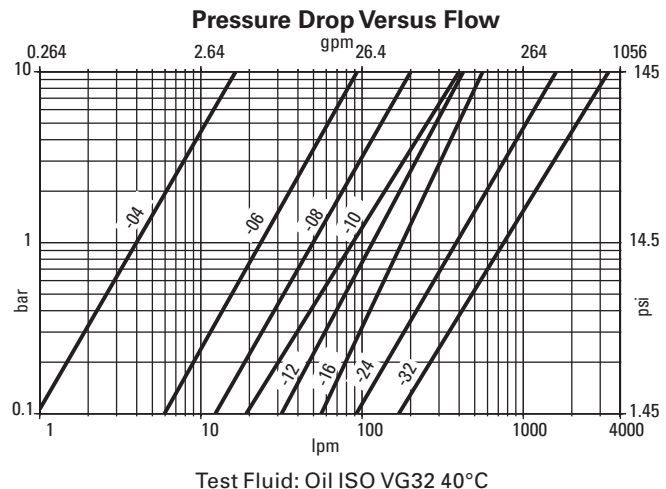

FD89 - 2000 Series

316 Stainless Steel
ISO 16028 Interchange

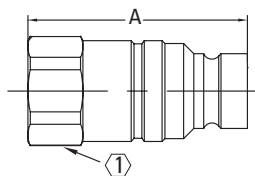

Figure 1

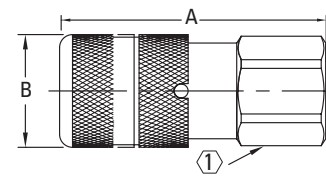
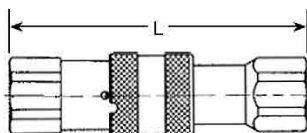

Figure 2

Dimensions

| Part Number | Coupling Type | Size | Body Size | Port Thread | Type | Fig. A | Dimensions B | | | | Hex ① | |
|-----------------|---------------|-------|-----------|--------------|------------|--------|--------------|--------|-------|--------|-------|--------|
| | | | | | | | mm | (in) | mm | (in) | mm | (in) |
| FD89-2001-04-04 | Female | 1/4 | 1/4 | 1/4-18 | Female NPT | 2 | 48.3 | (1.90) | 28.0 | (1.10) | 22 | (.87) |
| FD89-2002-04-04 | Male | 1/4 | 1/4 | 1/4-18 | Female NPT | 1 | 47.9 | (1.89) | | | 22 | (.87) |
| FD89-2001-06-06 | Female | 3/8 | 3/8 | 3/8-18 | Female NPT | 2 | 64.2 | (2.53) | 32.0 | (1.26) | 27 | (1.06) |
| FD89-2002-06-06 | Male | 3/8 | 3/8 | 3/8-18 | Female NPT | 1 | 60.0 | (2.36) | | | 24 | (.94) |
| FD89-2001-08-08 | Female | 1/2 | 1/2 | 1/2-14 | Female NPT | 2 | 73.8 | (2.91) | 38.0 | (1.50) | 32 | (1.26) |
| FD89-2002-08-08 | Male | 1/2 | 1/2 | 1/2-14 | Female NPT | 1 | 68.0 | (2.68) | | | 32 | (1.26) |
| FD89-2001-12-10 | Female | 5/8 | 3/4 | 3/4-14 | Female NPT | 2 | 80.9 | (3.19) | 42.0 | (1.65) | 36 | (1.42) |
| FD89-2002-12-10 | Male | 5/8 | 3/4 | 3/4-14 | Female NPT | 1 | 70.5 | (2.78) | | | 36 | (1.42) |
| FD89-2001-16-12 | Female | 3/4 | 1 | 1-11 1/2 | Female NPT | 2 | 92.9 | (3.67) | 48.0 | (1.89) | 46 | (1.81) |
| FD89-2002-16-12 | Male | 3/4 | 1 | 1-11 1/2 | Female NPT | 1 | 82.2 | (3.24) | | | 46 | (1.81) |
| FD89-2001-20-16 | Female | 1 | 1 1/4 | 1 1/4-11 1/2 | Female NPT | 2 | 106.2 | (4.18) | 55.0 | (2.17) | 55 | (2.17) |
| FD89-2002-20-16 | Male | 1 | 1 1/4 | 1 1/4-11 1/2 | Female NPT | 1 | 90.0 | (3.54) | | | 55 | (2.17) |
| FD89-2001-24-24 | Female | 1 1/2 | 1 1/2 | 1 1/2-11 1/2 | Female NPT | 2 | 132.4 | (5.21) | 80.0 | (3.15) | 65 | (2.56) |
| FD89-2002-24-24 | Male | 1 1/2 | 1 1/2 | 1 1/2-11 1/2 | Female NPT | 1 | 111.0 | (4.37) | | | 70 | (2.76) |
| FD89-2001-32-32 | Female | 2 | 2 | 2-11 1/2 | Female NPT | 2 | 156.6 | (6.17) | 100.0 | (3.94) | 80 | (3.15) |
| FD89-2002-32-32 | Male | 2 | 2 | 2-11 1/2 | Female NPT | 1 | 123.8 | (4.87) | | | 75 | (2.95) |

Connected Length



| Body Size | Port Size | Connected Length "L" | |
|-----------|-----------|----------------------|--------|
| | | mm | (in) |
| 1/4 | 1/4 | 85.2 | (3.35) |
| 3/8 | 3/8 | 108.6 | (4.28) |
| 1/2 | 1/2 | 124.5 | (4.90) |
| 5/8 | 3/4 | 133.8 | (5.27) |
| 3/4 | 1 | 153.3 | (6.04) |
| 1 | 1 1/4 | 173.0 | (6.81) |
| 1 1/2 | 1 1/2 | 214.8 | (8.46) |
| 2 | 2 | 241.5 | (9.51) |

Dust Caps and Dust Plugs

| Body Size | Part Number | Coupling Type | Cap Material |
|---------------|-----------------|---------------|--------------|
| 1/4 - 1/4 | FD89-1009-04 | Female | PVC |
| 3/8 - 3/8 | FD89-1009-06 | Female | PVC |
| 1/2 - 1/2 | FD89-1009-08-08 | Female | PVC |
| 3/4 - 5/8 | FD89-1009-12 | Female | PVC |
| 1 - 3/4 | FD89-1009-16 | Female | PVC |
| 1 1/4 - 1 | FD89-1009-20 | Female | PVC |
| 1 1/2 - 1 1/2 | FD89-1009-24 | Female | Aluminum |
| 2 - 2 | FD89-1009-32 | Female | Aluminum |

| Body Size | Part Number | Coupling Type | Cap Material |
|---------------|-----------------|---------------|--------------|
| 1/4 - 1/4 | FD89-1008-04 | Male | PVC |
| 3/8 - 3/8 | FD89-1008-06-06 | Male | PVC |
| 1/2 - 1/2 | FD89-1008-08-08 | Male | PVC |
| 3/4 - 5/8 | FD89-1008-12 | Male | PVC |
| 1 - 3/4 | FD89-1008-16 | Male | PVC |
| 1 1/4 - 1 | FD89-1008-20 | Male | PVC |
| 1 1/2 - 1 1/2 | FD89-1008-24 | Male | Aluminum |
| 2 - 2 | FD89-1008-32 | Male | Aluminum |

FD96 Series

High Pressure Thread to
Connect Flush Face



The FD96 High Pressure Thread Together Flush Face Series is designed for high pressure and high impulse applications for hydraulic circuits. The FD96 design provides low connect and disconnect force in hydraulic circuits where trapped residual pressure must be addressed. The flush face design limits contamination and unwanted fluid loss. The FD96 Series is available in sizes 1/4" through 2" to best meet your specific size requirements.

Product Features

- Thread together design allows connection and disconnection under pressure up to 4,300 psi
- Low connection force
- Dual flush-face valving with non-spill design
- Working pressures up to 8,500 psi
- Body material – High resistance carbon steel with zinc trivalent chromate plating and black oxide plating

Applications

- Hydraulic fluid transfer
- High impulse hydraulics
- Oil field
- Mining



Physical Characteristics

| Body Size | Max. Operating Pressure | | | Min. Burst Pressure | | | Rated Flow | Fluid Loss | Req. Torque to Connect |
|-----------|-------------------------|-------------|-------------|---------------------|----------------|----------------|-------------|------------|------------------------|
| | Connected | Male Half | Female Half | Connected | Male Half | Female Half | | | |
| | bar (psi) | bar (psi) | bar (psi) | bar (psi) | bar (psi) | bar (psi) | | | |
| 1/4 | 600 (8,700) | 600 (8,700) | 420 (6,090) | 1,500 (21,750) | 1,500 (21,750) | 1,260 (18,270) | 12 (3.2) | .012 | 29-37 (40-50) |
| 3/8 | 550 (7,980) | 550 (7,980) | 330 (4,785) | 1,400 (20,300) | 1,400 (20,300) | 1,000 (14,500) | 23 (6.1) | .040 | 37-44 (50-60) |
| 1/2 | 550 (7,980) | 550 (7,980) | 330 (4,785) | 1,400 (20,300) | 1,400 (20,300) | 1,000 (14,500) | 45 (11.9) | .025 | 48-55 (65-75) |
| 3/4 | 550 (7,980) | 550 (7,980) | 330 (4,785) | 1,400 (20,300) | 1,400 (20,300) | 1,000 (14,500) | 74 (19.6) | .033 | 52-59 (70-80) |
| 1 | 500 (7,250) | 500 (7,250) | 330 (4,785) | 1,250 (18,125) | 1,250 (18,125) | 1,000 (14,500) | 100 (26.5) | .018 | 66-81 (90-110) |
| 1 1/4 | 470 (6,800) | 470 (6,800) | 300 (4,350) | 1,200 (17,400) | 1,200 (17,400) | 800 (11,600) | 189 (50.1) | .060 | 92-107 (125-145) |
| 1 1/2 | 400 (5,800) | 400 (5,800) | 270 (3,915) | 1,700 (15,950) | 1,100 (15,950) | 800 (11,600) | 288 (76.3) | .200 | 114-129 (155-175) |
| 2 | 350 (5,080) | 350 (5,080) | 270 (3,915) | 1,100 (15,950) | 1,100 (15,950) | 800 (11,600) | 379 (100.4) | .350 | 236-258 (320-355) |

Flow Data

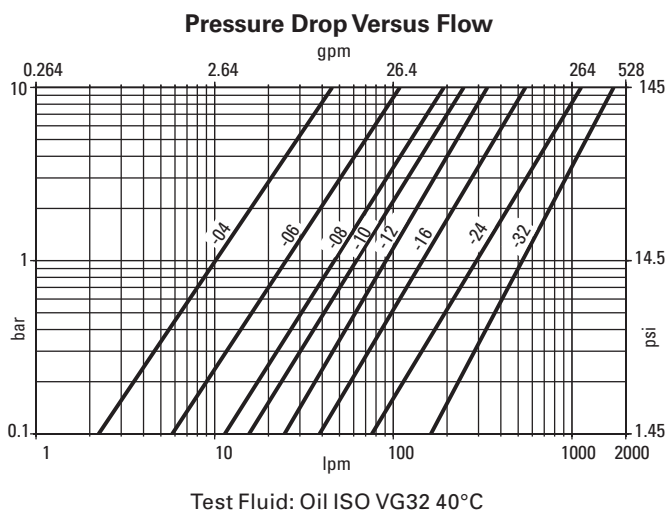

Connected Length

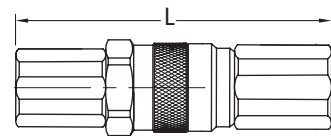

| Body Size | Port Size | Connected Length "L" | |
|-----------|-----------|----------------------|---------|
| | | mm | (in) |
| 1/4 | 3/8 | 90.0 | (3.54) |
| 3/8 | 3/8 | 131.0 | (5.16) |
| 3/8 | 1/2 | 131.0 | (5.16) |
| 1/2 | 1/2 | 155.0 | (6.10) |
| 1/2 | 3/4 | 160.0 | (6.30) |
| 3/4 | 3/4 | 165.0 | (6.50) |
| 1 | 1 | 190.4 | (7.50) |
| 1 | 1 1/4 | 170.0 | (6.69) |
| 1 1/2 | 1 1/2 | 256.0 | (10.08) |
| 2 | 2 | 363.5 | (14.31) |

FD96 Series

High Pressure Thread to Connect Flush Face

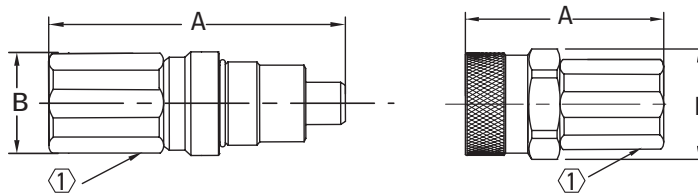

Figure 1

Figure 2

Dimensions (Female NPT)

| Part Number | Coupling Type | Body Size | Port Size | Thread | Type | Fig. | Dimensions | | | | | |
|-----------------|---------------|-----------|-----------|--------------|------------|------|------------|--------|-------|--------|----|--------|
| | | | | | | | A | B | Hex ① | | | |
| | | | | | | | mm | (in) | mm | (in) | mm | (in) |
| FD96-1001-06-06 | Female | 3/8 | 3/8 | 3/8-18 | Female NPT | 2 | 65.8 | (2.59) | 41.8 | (1.65) | 30 | (1.18) |
| FD96-1002-06-06 | Male | 3/8 | 3/8 | 3/8-18 | Female NPT | 1 | 82.5 | (3.25) | 37.8 | (1.49) | 27 | (1.06) |
| FD96-1001-08-06 | Female | 3/8 | 1/2 | 1/2-14 | Female NPT | 2 | 70.8 | (2.79) | 41.8 | (1.65) | 30 | (1.18) |
| FD96-1002-08-06 | Male | 3/8 | 1/2 | 1/2-14 | Female NPT | 1 | 85.0 | (3.35) | 37.8 | (1.49) | 27 | (1.06) |
| FD96-1001-08-08 | Female | 1/2 | 1/2 | 1/2-14 | Female NPT | 2 | 77.8 | (3.06) | 49.8 | (1.96) | 36 | (1.42) |
| FD96-1002-08-08 | Male | 1/2 | 1/2 | 1/2-14 | Female NPT | 1 | 95.0 | (3.74) | 45.8 | (1.80) | 36 | (1.42) |
| FD96-1001-12-08 | Female | 1/2 | 3/4 | 3/4-14 | Female NPT | 2 | 84.8 | (3.06) | 49.8 | (1.96) | 36 | (1.42) |
| FD96-1002-12-08 | Male | 1/2 | 3/4 | 3/4-14 | Female NPT | 1 | 97.4 | (3.83) | 45.8 | (1.80) | 36 | (1.42) |
| FD96-1001-12-12 | Female | 3/4 | 3/4 | 3/4-14 | Female NPT | 2 | 84.9 | (3.34) | 53.8 | (2.12) | 41 | (1.61) |
| FD96-1002-12-12 | Male | 3/4 | 3/4 | 3/4-14 | Female NPT | 1 | 99.0 | (3.90) | 49.8 | (1.96) | 36 | (1.42) |
| FD96-1001-12-16 | Female | 1 | 3/4 | 3/4-14 | Female NPT | 2 | 96.7 | (3.81) | 58.8 | (2.31) | 46 | (1.81) |
| FD96-1002-12-16 | Male | 1 | 3/4 | 3/4-14 | Female NPT | 1 | 113.6 | (4.47) | 54.8 | (2.16) | 46 | (1.81) |
| FD96-1001-16-16 | Female | 1 | 1 | 1-11 1/2 | Female NPT | 2 | 99.7 | (3.93) | 58.8 | (2.31) | 46 | (1.81) |
| FD96-1002-16-16 | Male | 1 | 1 | 1-11 1/2 | Female NPT | 1 | 113.6 | (4.47) | 54.8 | (2.16) | 46 | (1.81) |
| FD96-1001-16-20 | Female | 1 1/4 | 1 | 1-11 1/2 | Female NPT | 2 | 105.8 | (4.17) | 69.8 | (2.75) | 55 | (2.17) |
| FD96-1002-16-20 | Male | 1 1/4 | 1 | 1-11 1/2 | Female NPT | 1 | 123.4 | (4.86) | 64.5 | (2.54) | 55 | (2.17) |
| FD96-1001-20-20 | Female | 1 1/4 | 1 1/4 | 1 1/4-11 1/2 | Female NPT | 2 | 106.8 | (4.20) | 69.8 | (2.75) | 55 | (2.17) |
| FD96-1002-20-20 | Male | 1 1/4 | 1 1/4 | 1 1/4-11 1/2 | Female NPT | 1 | 123.4 | (4.86) | 64.5 | (2.54) | 55 | (2.17) |
| FD96-1001-20-24 | Female | 1 1/2 | 1 1/4 | 1 1/4-11 1/2 | Female NPT | 2 | 133.5 | (5.26) | 92.0 | (3.62) | 65 | (2.56) |
| FD96-1002-20-24 | Male | 1 1/2 | 1 1/4 | 1 1/4-11 1/2 | Female NPT | 1 | 150.0 | (5.91) | 89.8 | (3.54) | 65 | (2.56) |
| FD96-1001-24-24 | Female | 1 1/2 | 1 1/2 | 1 1/2-11 1/2 | Female NPT | 2 | 133.5 | (5.26) | 92.0 | (3.62) | 65 | (2.56) |
| FD96-1002-24-24 | Male | 1 1/2 | 1 1/2 | 1 1/2-11 1/2 | Female NPT | 1 | 150.0 | (5.91) | 89.8 | (3.54) | 65 | (2.56) |
| FD96-1001-32-32 | Female | 2 | 2 | 2-11 1/2 | Female NPT | 2 | 224.8 | (8.85) | 200.0 | (7.87) | 90 | (3.54) |
| FD96-1002-32-32 | Male | 2 | 2 | 2-11 1/2 | Female NPT | 1 | 218.4 | (8.60) | 145.0 | (5.71) | 90 | (3.54) |

Dimensions (Female SAE O-ring)

| Part Number | Coupling Type | Body Size | Port Size | Thread | Type | Fig. | Dimensions | | | | | |
|-----------------|---------------|-----------|-----------|--------------|-------------------|------|------------|--------|-------|--------|----|--------|
| | | | | | | | A | B | Hex ① | | | |
| | | | | | | | mm | (in) | mm | (in) | mm | (in) |
| FD96-1004-06-04 | Female | 1/4 | 3/8 | 9/16-18 UNF | Female SAE O-ring | 2 | 57.1 | (2.25) | 38.8 | (1.53) | 27 | (1.06) |
| FD96-1005-06-04 | Male | 1/4 | 3/8 | 9/16-18 UNF | Female SAE O-ring | 1 | 72.8 | (2.87) | 34.8 | (1.37) | 22 | (.87) |
| FD96-1004-08-06 | Female | 3/8 | 1/2 | 3/4-16 UNF | Female SAE O-ring | 2 | 70.8 | (2.79) | 41.8 | (1.65) | 30 | (1.18) |
| FD96-1005-08-06 | Male | 3/8 | 1/2 | 3/4-16 UNF | Female SAE O-ring | 1 | 87.0 | (3.43) | 37.8 | (1.49) | 27 | (1.06) |
| FD96-1004-12-08 | Female | 1/2 | 3/4 | 11/16-12 UNF | Female SAE O-ring | 2 | 84.8 | (3.06) | 49.8 | (1.96) | 36 | (1.42) |
| FD96-1005-12-08 | Male | 1/2 | 3/4 | 11/16-12 UNF | Female SAE O-ring | 1 | 100.4 | (3.95) | 45.8 | (1.80) | 36 | (1.42) |
| FD96-1004-12-12 | Female | 3/4 | 3/4 | 11/16-12 UNF | Female SAE O-ring | 2 | 84.9 | (3.34) | 53.8 | (2.12) | 41 | (1.61) |
| FD96-1005-12-12 | Male | 3/4 | 3/4 | 11/16-12 UN | Female SAE O-ring | 1 | 102.0 | (4.02) | 49.8 | (1.96) | 36 | (1.42) |
| FD96-1004-12-16 | Female | 1 | 3/4 | 11/16-12 UN | Female SAE O-ring | 2 | 99.7 | (3.93) | 58.8 | (2.31) | 46 | (1.81) |
| FD96-1005-12-16 | Male | 1 | 3/4 | 11/16-12 UN | Female SAE O-ring | 1 | 115.6 | (4.55) | 54.8 | (2.16) | 46 | (1.81) |
| FD96-1004-16-16 | Female | 1 | 1 | 15/16-12 UN | Female SAE O-ring | 2 | 99.7 | (3.93) | 58.8 | (2.31) | 46 | (1.81) |
| FD96-1005-16-16 | Male | 1 | 1 | 15/16-12 UN | Female SAE O-ring | 1 | 113.6 | (4.47) | 54.8 | (2.16) | 46 | (1.81) |
| FD96-1004-16-20 | Female | 1 1/4 | 1 | 15/16-12 UN | Female SAE O-ring | 2 | 105.8 | (4.17) | 69.8 | (2.75) | 55 | (2.17) |
| FD96-1005-16-20 | Male | 1 1/4 | 1 | 15/16-12 UN | Female SAE O-ring | 1 | 125.4 | (4.94) | 64.5 | (2.54) | 55 | (2.17) |
| FD96-1004-20-20 | Female | 1 1/4 | 1 1/4 | 15/8-12 UN | Female SAE O-ring | 2 | 106.8 | (4.20) | 69.8 | (2.75) | 55 | (2.17) |
| FD96-1005-20-20 | Male | 1 1/4 | 1 1/4 | 15/8-12 UN | Female SAE O-ring | 1 | 123.4 | (4.86) | 64.5 | (2.54) | 55 | (2.17) |
| FD96-1004-20-24 | Female | 1 1/2 | 1 1/4 | 15/8-12 UN | Female SAE O-ring | 2 | 133.5 | (5.26) | 92.0 | (3.62) | 65 | (2.56) |
| FD96-1005-20-24 | Male | 1 1/2 | 1 1/4 | 15/8-12 UN | Female SAE O-ring | 1 | 150.0 | (5.91) | 89.8 | (3.54) | 65 | (2.56) |
| FD96-1004-24-24 | Female | 1 1/2 | 1 1/2 | 17/8-12 UN | Female SAE O-ring | 2 | 133.5 | (5.26) | 92.0 | (3.62) | 65 | (2.56) |
| FD96-1005-24-24 | Male | 1 1/2 | 1 1/2 | 17/8-12 UN | Female SAE O-ring | 1 | 150.0 | (5.91) | 89.8 | (3.54) | 65 | (2.56) |
| FD96-1004-32-32 | Female | 2 | 2 | 21/2-12 UN | Female SAE O-ring | 2 | 224.8 | (8.85) | 200.0 | (7.87) | 90 | (3.54) |
| FD96-1005-32-32 | Male | 2 | 2 | 21/2-12 UN | Female SAE O-ring | 1 | 218.4 | (8.60) | 145.0 | (5.71) | 90 | (3.54) |

Dust Caps and Dust Plugs

| Body Size | Part Number | Coupling Type | Cap Material | Body Size | Part Number | Coupling Type | Cap Material |
|-----------|--------------|---------------|--------------|-----------|--------------|---------------|--------------|
| 1/4 | FD96-1009-04 | Female | Aluminum | 1/4 | FD96-1010-04 | Male | Aluminum |
| 3/8 | FD96-1009-06 | Female | Aluminum | 3/8 | FD96-1010-06 | Male | Aluminum |
| 1/2 | FD96-1009-08 | Female | Aluminum | 1/2 | FD96-1010-08 | Male | Aluminum |
| 3/4 | FD96-1009-12 | Female | Aluminum | 3/4 | FD96-1010-12 | Male | Aluminum |
| 1 | FD96-1009-16 | Female | Aluminum | 1 | FD96-1010-16 | Male | Aluminum |
| 1 1/4 | FD96-1009-20 | Female | Aluminum | 1 1/4 | FD96-1010-20 | Male | Aluminum |
| 1 1/2 | FD96-1009-24 | Female | Aluminum | 1 1/2 | FD96-1010-24 | Male | Aluminum |
| 2 | FD96-1009-32 | Female | Aluminum | 2 | FD96-1010-32 | Male | Aluminum |

FD99 Series

High Pressure Flush Face
ISO 16028 Interchange



The FD99 High Pressure Flush Face Series is designed for those applications where quick and easy connections and non-spill performance are critical. Ideal for use where global interchangeability and high pressure applications a must. The high pressure design and reduced pressure drop exceeds industry standards for ISO 16028 standards. The FD99 Series is available in sizes from 1/4" through 1-1/2" to best meet your specific size requirements.

Product Features

- Meets dimensional requirements of ISO 16028
- Push-to-connect latching
- Dual flush-face valving with non-spill design
- Safety sleeve lock
- Anti-extrusion Teflon® seal
- Body material – High resistance carbon steel with zinc trivalent chromate plating
- Standard seal material – Nitrile/Teflon®, additional material available on request

Physical Characteristics

| ISO Size | Body Size | Max. Operating Pressure | | | | | | Min. Burst Pressure | | | | | | Rated Flow L/min (gpm) | Fluid Loss cc. | Force to Connect N (lbs.) | | |
|----------|-----------|-------------------------|---------|-----------|---------|-------------|---------|---------------------|----------|-----------|----------|-------------|----------|---------------------------|-------------------|------------------------------|-----|-------|
| | | Connected | | Male Half | | Female Half | | Connected | | Male Half | | Female Half | | | | | | |
| | | bar | (psi) | bar | (psi) | bar | (psi) | bar | (psi) | bar | (psi) | bar | (psi) | | | | | |
| 6.3 | 1/4 | 420 | (6,090) | 420 | (6,090) | 420 | (6,090) | 1,260 | (18,270) | 1,260 | (18,270) | 1,260 | (18,270) | 12 | (3.2) | .006 | 160 | (36) |
| 10.0 | 3/8 | 350 | (5,075) | 350 | (5,075) | 350 | (5,075) | 1,000 | (14,500) | 1,000 | (14,500) | 1,000 | (14,500) | 23 | (6.1) | .012 | 160 | (36) |
| 12.5 | 1/2 | 330 | (4,785) | 330 | (4,785) | 330 | (4,785) | 1,000 | (14,500) | 1,000 | (14,500) | 1,000 | (14,500) | 45 | (11.9) | .020 | 200 | (45) |
| 16.0 | 5/8 | 330 | (4,785) | 330 | (4,785) | 330 | (4,785) | 1,000 | (14,500) | 1,000 | (14,500) | 1,000 | (14,500) | 74 | (19.5) | .026 | 200 | (45) |
| 19.0 | 3/4 | 330 | (4,785) | 330 | (4,785) | 330 | (4,785) | 1,000 | (14,500) | 1,000 | (14,500) | 1,000 | (14,500) | 100 | (26.4) | .032 | 200 | (45) |
| 25.0 | 1 | 300 | (4,350) | 300 | (4,350) | 300 | (4,350) | 800 | (11,600) | 800 | (11,600) | 800 | (11,600) | 189 | (50.0) | .035 | 280 | (63) |
| 27.0 | 1 1/4 | 300 | (4,350) | 300 | (4,350) | 300 | (4,350) | 800 | (11,600) | 800 | (11,600) | 800 | (11,600) | 225 | (59.6) | .017 | 490 | (110) |
| 31.5 | 1 1/2 | 270 | (3,915) | 270 | (3,915) | 270 | (3,915) | 800 | (11,600) | 800 | (11,600) | 700 | (10,150) | 288 | (76.3) | .050 | 580 | (131) |



Applications

- Hydraulic fluid transfer
- Agriculture equipment
- High impulse hydraulics
- Construction equipment and implements

Flow Data

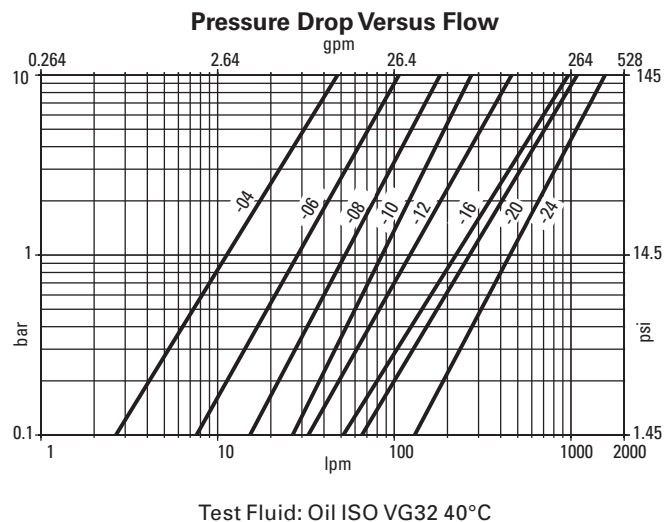

FD99 Series

High Pressure Flush Face
ISO 16028 Interchange

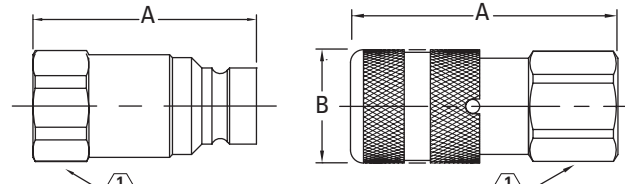
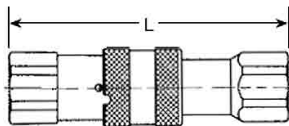

Figure 1

Figure 2

Dimensions (NPT)

| Part Number | Coupling Type | Body Size | Port Size | Thread | Type | Fig. | Dimensions A | | Dimensions B | | Hex ① | |
|-----------------|---------------|-----------|-----------|--------------|------------|------|--------------|--------|--------------|--------|-------|--------|
| | | | | | | | mm | (in) | mm | (in) | mm | (in) |
| FD99-1001-04-04 | Female | 1/4 | 1/4 | 1/4-18 | Female NPT | 2 | 53.1 | (2.09) | 28.0 | (1.10) | 27 | (1.06) |
| FD99-1002-04-04 | Male | 1/4 | 1/4 | 1/4-18 | Female NPT | 1 | 50.9 | (1.89) | | | 22 | (.87) |
| FD99-1001-06-06 | Female | 3/8 | 3/8 | 3/8-18 | Female NPT | 2 | 64.8 | (2.55) | 32.0 | (1.26) | 30 | (1.18) |
| FD99-1002-06-06 | Male | 3/8 | 3/8 | 3/8-18 | Female NPT | 1 | 60.0 | (2.36) | | | 27 | (1.06) |
| FD99-1001-08-06 | Female | 3/8 | 1/2 | 1/2-14 | Female NPT | 2 | 69.8 | (2.75) | 32.0 | (1.26) | 30 | (1.18) |
| FD99-1002-08-06 | Male | 3/8 | 1/2 | 1/2-14 | Female NPT | 1 | 62.5 | (2.46) | | | 27 | (1.06) |
| FD99-1001-08-08 | Female | 1/2 | 1/2 | 1/2-14 | Female NPT | 2 | 76.8 | (3.02) | 38.0 | (1.50) | 36 | (1.47) |
| FD99-1002-08-08 | Male | 1/2 | 1/2 | 1/2-14 | Female NPT | 1 | 68.0 | (2.68) | | | 36 | (1.47) |
| FD99-1001-12-08 | Female | 1/2 | 3/4 | 3/4-14 | Female NPT | 2 | 83.8 | (3.30) | 38.0 | (1.50) | 36 | (1.42) |
| FD99-1002-12-08 | Male | 1/2 | 3/4 | 3/4-14 | Female NPT | 1 | 70.5 | (2.78) | | | 36 | (1.42) |
| FD99-1001-12-10 | Female | 5/8 | 3/4 | 3/4-14 | Female NPT | 2 | 84.0 | (3.31) | 42.0 | (1.65) | 41 | (1.61) |
| FD99-1002-12-10 | Male | 5/8 | 3/4 | 3/4-14 | Female NPT | 1 | 73.0 | (2.87) | | | 36 | (1.42) |
| FD99-1001-12-12 | Female | 3/4 | 3/4 | 3/4-14 | Female NPT | 2 | 95.8 | (3.77) | 48.0 | (1.89) | 46 | (1.81) |
| FD99-1002-12-12 | Male | 3/4 | 3/4 | 3/4-14 | Female NPT | 1 | 83.7 | (3.30) | | | 46 | (1.81) |
| FD99-1001-16-12 | Female | 3/4 | 1 | 1-11 1/2 | Female NPT | 2 | 98.8 | (3.89) | 48.0 | (1.89) | 46 | (1.81) |
| FD99-1002-16-12 | Male | 3/4 | 1 | 1-11 1/2 | Female NPT | 1 | 83.7 | (3.30) | | | 46 | (1.81) |
| FD99-1001-16-16 | Female | 1 | 1 | 1-11 1/2 | Female NPT | 2 | 104.8 | (4.13) | 55.0 | (2.17) | 55 | (2.17) |
| FD99-1002-16-16 | Male | 1 | 1 | 1-11 1/2 | Female NPT | 1 | 96.8 | (3.84) | | | 55 | (2.17) |
| FD99-1001-20-16 | Female | 1 | 1 1/4 | 1 1/4-11 1/2 | Female NPT | 2 | 105.8 | (4.17) | 55.0 | (2.17) | 55 | (2.17) |
| FD99-1002-20-16 | Male | 1 | 1 1/4 | 1 1/4-11 1/2 | Female NPT | 1 | 90.0 | (3.54) | | | 55 | (2.17) |
| FD99-1001-20-20 | Female | 1 1/4 | 1 1/4 | 1 1/4-11 1/2 | Female NPT | 2 | 125.1 | (4.93) | 65.0 | (2.56) | 55 | (2.17) |
| FD99-1002-20-20 | Male | 1 1/4 | 1 1/4 | 1 1/4-11 1/2 | Female NPT | 1 | 105.0 | (4.13) | | | 55 | (2.17) |
| FD99-1001-24-24 | Female | 1 1/2 | 1 1/2 | 1 1/2-11 1/2 | Female NPT | 2 | 132.4 | (5.21) | 80.0 | (3.15) | 65 | (2.56) |
| FD99-1002-24-24 | Male | 1 1/2 | 1 1/2 | 1 1/2-11 1/2 | Female NPT | 1 | 111.1 | (4.37) | | | 65 | (2.56) |



Connected Length

| Body Size | Port Size | Connected Length "L" | |
|-----------|-----------|----------------------|--------|
| | | mm | (in) |
| 1/4 | 1/4 | 90.2 | (3.55) |
| 3/8 | 3/8 | 109.0 | (4.29) |
| 3/8 | 1/2 | 116.2 | (4.58) |
| 3/8 | 5/8 | 121.3 | (4.78) |
| 1/2 | 1/2 | 127.5 | (5.02) |
| 1/2 | 3/4 | 137.0 | (5.39) |
| 3/4 | 3/4 | 160.5 | (6.32) |
| 5/8 | 3/4 | 139.4 | (5.49) |
| 3/4 | 1 | 160.5 | (6.32) |
| 1 | 1 1/4 | 173.0 | (6.81) |
| 1 1/4 | 1 1/4 | 206.9 | (8.15) |
| 1 1/2 | 1 1/2 | 215.0 | (8.46) |

Dust Caps and Dust Plugs

| Body Size | Part Number | Coupling Type | Cap Material |
|-----------|-----------------|---------------|--------------|
| 1/4 - 1/4 | FD89-1009-04 | Female | PVC |
| 3/8 - 3/8 | FD89-1009-06-06 | Female | PVC |
| 1/2 - 3/8 | FD89-1009-08-06 | Female | PVC |
| 1/2 - 1/2 | FD89-1009-08-08 | Female | PVC |
| 3/4 - 1/2 | FD89-1009-12-08 | Female | PVC |
| 3/4 | FD89-1009-12 | Female | PVC |
| 1 | FD89-1009-16 | Female | PVC |
| 1 1/4 | FD89-1009-20 | Female | PVC |
| 1 1/2 | FD89-1009-24 | Female | Aluminum |

| Body Size | Part Number | Coupling Type | Cap Material |
|-----------|-----------------|---------------|--------------|
| 1/4 - 1/4 | FD89-1008-04 | Male | PVC |
| 3/8 - 3/8 | FD89-1008-06-06 | Male | PVC |
| 1/2 - 3/8 | FD89-1008-08-06 | Male | PVC |
| 1/2 - 1/2 | FD89-1008-08-08 | Male | PVC |
| 3/4 - 1/2 | FD89-1008-12-08 | Male | PVC |
| 3/4 | FD89-1008-12 | Male | PVC |
| 1 | FD89-1008-16 | Male | PVC |
| 1 1/4 | FD89-1008-20 | Male | PVC |
| 1 1/2 | FD89-1008-24 | Male | Aluminum |

FD99 Series

High Pressure Flush Face
ISO 16028 Interchange

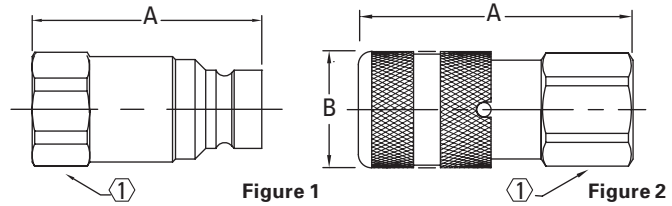

Dimensions (NPT)

| Part Number | Coupling Type | Body Size | Port Size | Thread | Type | Fig. | Dimensions A | | B | | Hex Ⓛ | |
|-----------------|---------------|-----------|-----------|--------------|------------|------|--------------|--------|------|--------|-------|--------|
| | | | | | | | mm | (in) | mm | (in) | mm | (in) |
| FD99-1004-06-04 | Female | 1/4 | 3/8 | 9/16-18 UNF | SAE O-ring | 2 | 56.1 | (2.21) | 28.0 | (1.10) | 27 | (1.06) |
| FD99-1005-06-04 | Male | 1/4 | 3/8 | 9/16-18 UNF | SAE O-ring | 1 | 50.9 | (2.00) | | | 22 | (.87) |
| FD99-1004-06-06 | Female | 3/8 | 3/8 | 9/16-18 UNF | SAE O-ring | 2 | 64.8 | (2.55) | 32.0 | (1.26) | 30 | (1.18) |
| FD99-1005-06-06 | Male | 3/8 | 3/8 | 9/16-18 UNF | SAE O-ring | 1 | 60.0 | (2.36) | | | 27 | (1.06) |
| FD99-1004-08-06 | Female | 3/8 | 1/2 | 3/4-16 UNF | SAE O-ring | 2 | 69.8 | (2.75) | 32.0 | (1.26) | 30 | (1.18) |
| FD99-1005-08-06 | Male | 3/8 | 1/2 | 3/4-16 UNF | SAE O-ring | 1 | 62.5 | (2.46) | | | 27 | (1.06) |
| FD99-1004-08-08 | Female | 1/2 | 1/2 | 3/4-16 UNF | SAE O-ring | 2 | 76.8 | (3.02) | 38.0 | (1.50) | 36 | (1.42) |
| FD99-1005-08-08 | Male | 1/2 | 1/2 | 3/4-16 UNF | SAE O-ring | 1 | 68.0 | (2.68) | | | 36 | (1.18) |
| FD99-1004-10-06 | Female | 3/8 | 5/8 | 7/8-14 UNF | SAE O-ring | 2 | 71.8 | (2.83) | 32.0 | (1.26) | 30 | (1.18) |
| FD99-1005-10-06 | Male | 3/8 | 5/8 | 7/8-14 UNF | SAE O-ring | 1 | 65.5 | (2.58) | | | 30 | (1.18) |
| FD99-1004-10-08 | Female | 1/2 | 5/8 | 7/8-14 UNF | SAE O-ring | 2 | 78.8 | (3.10) | 38.0 | (1.50) | 36 | (1.42) |
| FD99-1005-10-08 | Male | 1/2 | 5/8 | 7/8-14 UNF | SAE O-ring | 1 | 70.0 | (2.76) | | | 36 | (1.42) |
| FD99-1004-12-08 | Female | 1/2 | 3/4 | 1 1/16-12 UN | SAE O-ring | 2 | 83.8 | (3.30) | 38.0 | (1.50) | 36 | (1.42) |
| FD99-1005-12-08 | Male | 1/2 | 3/4 | 1 1/16-12 UN | SAE O-ring | 1 | 72.5 | (2.85) | | | 36 | (1.42) |
| FD99-1004-12-10 | Female | 5/8 | 3/4 | 1 1/16-12 UN | SAE O-ring | 2 | 84.0 | (3.31) | 42.0 | (1.65) | 41 | (1.61) |
| FD99-1005-12-10 | Male | 5/8 | 3/4 | 1 1/16-12 UN | SAE O-ring | 1 | 73.0 | (2.87) | | | 37 | (1.42) |
| FD99-1004-12-12 | Female | 3/4 | 3/4 | 1 1/16-12 UN | SAE O-ring | 2 | 98.8 | (3.89) | 48.0 | (2.89) | 46 | (1.81) |
| FD99-1005-12-12 | Male | 3/4 | 3/4 | 1 1/16-12 UN | SAE O-ring | 1 | 83.7 | (3.30) | | | 46 | (1.81) |
| FD99-1004-16-12 | Female | 3/4 | 1 | 1 5/16-12 UN | SAE O-ring | 2 | 98.8 | (3.89) | 48.0 | (1.89) | 46 | (1.81) |
| FD99-1005-16-12 | Male | 3/4 | 1 | 1 5/16-12 UN | SAE O-ring | 1 | 83.7 | (3.03) | | | 46 | (1.81) |
| FD99-1004-16-16 | Female | 1 | 1 | 1 5/16-12 UN | SAE O-ring | 2 | 104.8 | (4.13) | 55.0 | (2.17) | 55 | (2.17) |
| FD99-1005-16-16 | Male | 1 | 1 | 1 5/16-12 UN | SAE O-ring | 1 | 96.8 | (3.81) | | | 55 | (2.17) |
| FD99-1004-20-16 | Female | 1 | 1 1/4 | 1 5/8-12 UN | SAE O-ring | 2 | 105.8 | (4.17) | 55.0 | (2.17) | 55 | (2.17) |
| FD99-1005-20-16 | Male | 1 | 1 1/4 | 1 5/8-12 UN | SAE O-ring | 1 | 90.0 | (3.54) | | | 55 | (2.17) |
| FD99-1004-20-20 | Female | 1 1/4 | 1 1/4 | 1 5/8-12 UN | SAE O-ring | 2 | 125.1 | (4.93) | 65.0 | (2.56) | 55 | (2.17) |
| FD99-1005-20-20 | Male | 1 1/4 | 1 1/4 | 1 5/8-12 UN | SAE O-ring | 1 | 105.0 | (4.13) | | | 55 | (2.17) |
| FD99-1004-24-24 | Female | 1 1/2 | 1 1/2 | 1 7/8-12 UN | SAE O-ring | 2 | 132.4 | (5.21) | 80.0 | (3.15) | 65 | (2.56) |
| FD99-1005-24-25 | Male | 1 1/2 | 1 1/2 | 1 7/8-12 UN | SAE O-ring | 1 | 111.1 | (4.37) | | | 65 | (2.56) |

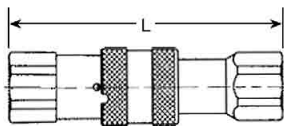

Connected Length

| Body Size | Port Size | Connected Length "L" | |
|-----------|-----------|----------------------|--------|
| | | mm | (in) |
| 1/4 | 1/4 | 96.2 | (3.79) |
| 3/8 | 3/8 | 109.0 | (4.29) |
| 3/8 | 1/2 | 116.5 | (4.59) |
| 3/8 | 5/8 | 121.3 | (4.78) |
| 1/2 | 1/2 | 127.5 | (5.02) |
| 1/2 | 3/4 | 139.0 | (5.47) |
| 1/2 | 5/8 | 131.5 | (5.18) |
| 3/4 | 3/4 | 166.5 | (6.32) |
| 5/8 | 3/4 | 139.5 | (5.49) |
| 3/4 | 1 | 161.0 | (6.34) |
| 1 | 1 | 178.6 | (7.03) |
| 1 | 1 1/4 | 173.0 | (6.81) |
| 1 1/4 | 1 1/4 | 206.9 | (8.15) |
| 1 1/2 | 1 1/2 | 215.0 | (8.46) |

Dust Caps and Dust Plugs

| Body Size | Part Number | Coupling Type | Cap Material |
|-----------|-----------------|---------------|--------------|
| 3/8 - 1/4 | FD89-1009-04 | Female | PVC |
| 3/8 - 3/8 | FD89-1009-06-06 | Female | PVC |
| 1/2 - 3/8 | FD89-1009-08-06 | Female | PVC |
| 3/8 - 1/2 | FD89-1009-08-08 | Female | PVC |
| 3/4 - 1/2 | FD89-1009-12-08 | Female | PVC |
| 3/4 | FD89-1009-12 | Female | PVC |
| 1 | FD89-1009-16 | Female | PVC |
| 1 1/4 | FD89-1009-20 | Female | PVC |
| 1 1/2 | FD89-1009-24 | Female | Aluminum |

| Body Size | Part Number | Coupling Type | Cap Material |
|-----------|-----------------|---------------|--------------|
| 3/8 - 1/4 | FD89-1008-04 | Male | PVC |
| 3/8 - 3/8 | FD89-1008-06-06 | Male | PVC |
| 1/2 - 3/8 | FD89-1008-08-06 | Male | PVC |
| 1/2 - 1/2 | FD89-1008-08-08 | Male | PVC |
| 3/4 - 1/2 | FD89-1008-12-08 | Male | PVC |
| 3/4 | FD89-1008-12 | Male | PVC |
| 1 | FD89-1008-16 | Male | PVC |
| 1 1/4 | FD89-1008-20 | Male | PVC |
| 1 1/2 | FD89-1008-24 | Male | Aluminum |

FD72 Series

Connect Under Pressure - Farm
ISO 5675 Interchange



The FD72 Series coupling incorporates special valving allowing connection to a FD76 Series male half under pressure. The maximum operating pressure is 3,000 psi. Contains an over travel, self-sealing poppet valve construction for connecting to a pressurized male tip. Applications require that the tractor control valve be actuated to open the flow path and to equalize the pressure.

Product Features

- Push-to-connect for one-hand operation when sleeve is mounted
- Interchanges with ISO 5675 male tips
- Retaining ring groove on female half for bulkhead and breakaway frame mounting
- Standard seal material – Buna-N
- Standard body material – High resistance carbon steel with zinc trivalent plating

Applications

- Hydraulic fluid transfer
- Agricultural equipment

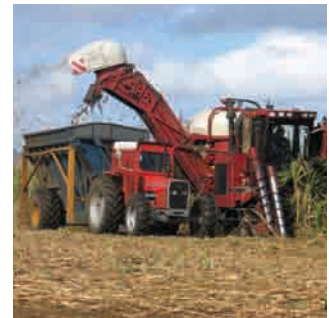

Physical Characteristics

| Body Size | Max. Operating Pressure | | Min. Burst Pressure Connected | | Vacuum Connected Only | Rated Flow | | Air Inclusion | Fluid Loss |
|-----------|-------------------------|---------|-------------------------------|----------|-----------------------|------------|-------|---------------|------------|
| | bar | (psi) | bar | (psi) | (in./Hg) | L/min | (gpm) | cc. max. | cc.max. |
| 5/8 | 207 | (3,000) | 827 | (12,000) | 28 | 61 | (16) | 2.8 | 2.8 |

Dimensions (Female NPT, Valved)

| Part Number Buna-N | Coupling Type | Body Size | Port Size | Thread | Type | Fig. | Dimensions | | | | | | | | | |
|-----------------------|---------------|-----------|-----------|--------|-------------|------|-------------|-------------|-------------|-------------|-----------|-------------|---|---|---|-------------|
| | | | | | | | A | B | C | D | E | Hex Ⓛ | | | | |
| FD76-1002-08-10 | Male | 5/8 | 1/2 | 1/2-14 | Female Pipe | 1 | 52.1 (2.05) | - | - | - | - | - | - | - | - | 26.9 (1.06) |
| FD72-1001-08-10 | Female | 5/8 | 1/2 | 1/2-14 | Female Pipe | 2 | 80.5 (3.17) | 38.6 (1.52) | 38.1 (1.50) | 35.8 (1.41) | 5.1 (.20) | 25.4 (1.00) | | | | |

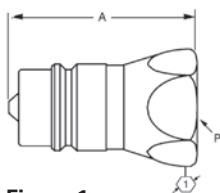

Figure 1

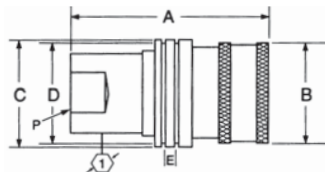

Figure 2

Dust Cap

| Part Number Buna-N | Body Size |
|-----------------------|-----------|
| 5657-10 | 5/8 |

Dust Cap



Dust Plug

| Part Number Buna-N | Body Size |
|-----------------------|-----------|
| 5659-10 | 5/8 |

Dust Plug



Break Away Frame

| Part Number Buna-N | Body Size |
|-----------------------|-----------|
| 5603 | 5/8 |

Break Away Frame



Flow Data

Pressure Drop Versus Flow Graph

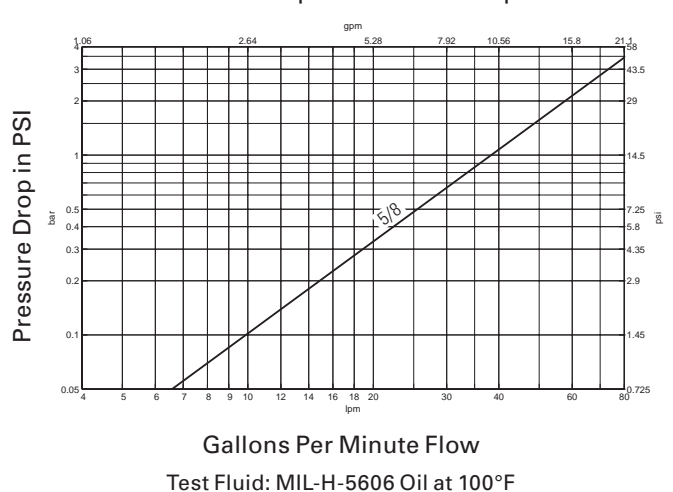

FD70 & FD76 Series

Male Tip – Farm
ISO 5675 Interchange



FD70 Deere



FD76 ISO

Designed to connect with female couplings on most older style John Deere farm equipment. The FD70 and FD76 Series quick disconnect couplings interchange with ISO 5675 quick disconnect couplings used on older farm tractors found throughout North America and abroad.



Product Features

- Optional ball or poppet style valving

Applications

- Hydraulic fluid transfer – Agricultural equipment

Dimensions

| Part Number Buna-N | Coupling Type | Body Size | Port Size | Thread | Type | Fig. | Dimensions | | | |
|-----------------------|------------------|--------------|--------------|--------|-------------------|------|------------|--------|-------|--------|
| | | | | | | | A | | Hex ① | |
| | | | | | | | mm | (in) | mm | (in) |
| FD70-1010-08-10 | Male | 5/8 | 1/2 | 3/4-16 | Female SAE O-ring | | 49.8 | (1.96) | 25.4 | (1.00) |
| FD76-1002-08-10 | Male | 5/8 | 1/2 | 1/2-14 | Female NPT | | 52.1 | (2.05) | 27.0 | (1.06) |
| FD76-1010-08-10 | Male | 5/8 | 1/2 | 3/4-16 | Female SAE O-ring | | 52.1 | (2.05) | 27.0 | (1.06) |

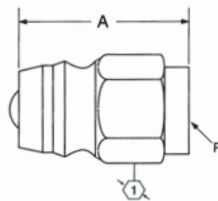

Figure 1

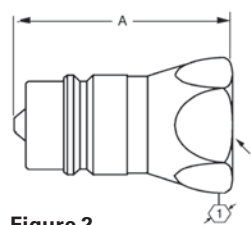

Figure 2

FD15 Series

Oil Sampling Valve



FD15 Series Oil Sampling Valve is designed for in-line sampling of system fluids without system shutdown, usually in less than one minute, and without fluid contamination.

Product Features

- Standard seal material – Buna
- Corrosion resistant plated steel with brass internal components
- Operating Temperature Range: -65°F to +275°F (-53°C to +135°C)
- Minimum Burst Pressure: 1200 psi
- Minimum Particle Restriction: 500 microns
- Maximum Torque to Operate: 10 in. lbs.

- FD15-1000-04 is qualified to the MIL-V-81940/2-1
- Note: This valve is not intended for aerospace applications.

Applications

- Engine oil
- Lubricating oil
- Transmission fluid and hydraulic fluids in mobile construction equipment, military vehicles, trucks and stationary equipment



Operation

- For best results, Eaton FD15 Oil Sampling Valves should be installed in dynamic fluid lines in low pressure and return lines. If only one sampling point can be chosen, it should be in the return line, upstream of any return line filter. This will insure a representative sample of all components in the fluid system for their present condition.

Instructions

1. Remove metal dustcover on discharge port.
2. Discharge approximately 200 ml of oil to flush valve by turning knurled knob 1/4 turn to the right. Dispose of this sample in the appropriate manner.
3. Locate clean oil sample bottle under discharge port. (Sample bottles are usually supplied by the oil analysis lab.)
4. Turn knurled knob 1/4 turn to the right until bottle is filled to the desired level. The knob can be backed off to throttle the rate of flow.
5. When bottle is filled let go of the knurled knob, the valve will close automatically. Replace metal dustcover wrench tight.

As required in MIL-V-81940/2-1 this valve's flow rate is between 100 and 1500 milliliters per minute at pressures from 0–50 psi. (MIL-V-81940/2-1 applies only to pressures from 50–300 psi.)

The 1/4" NPTF version is qualified to MIL-V-81940/2-1 and its performance is representative of the other inlet port configurations listed above. QPL-81940-9 6-5-89

FD15 Series

Oil Sampling Valve

Male Pipe Thread 50-300 psi

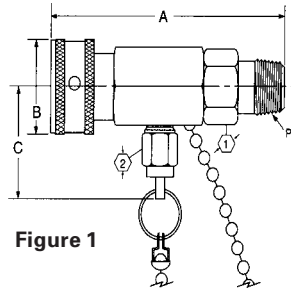

Figure 1

Male SAE O-ring Thread 50-300 psi

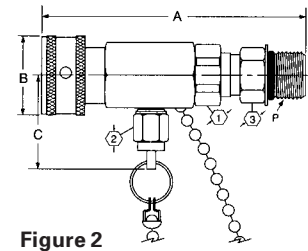

Figure 2

Dimensions (Male Pipe Thread)

| Part Number Buna-N | Sampling Type | Port Size | Thread | Type | Fig. | Dimensions | | | Hex ① | Hex ② | Hex ③ |
|-----------------------|------------------|--------------|--------|------------------|------|-------------|-------------|-------------|------------|-----------|---------|
| | | | | | | A | B | C | | | |
| | | | | | | mm (in) | mm (in) | mm (in) | mm (in) | mm (in) | mm (in) |
| FD15-1000-02 | 50-300 psi | 1/8 | 1/8-27 | Male Pipe Thread | 1 | 61.5 (2.42) | 25.4 (1.00) | 33.0 (1.30) | 17.5 (.69) | 9.7 (.38) | - |
| FD15-1000-04 | 50-300 psi | 1/4 | 1/4-18 | Male Pipe Thread | 1 | 65.0 (2.56) | 25.4 (1.00) | 33.0 (1.30) | 17.5 (.69) | 9.7 (.38) | - |

Dimensions (Male SAE O-ring Thread)

| Part Number Buna-N | Sampling Type | Port Size | Thread | Type | Fig. | Dimensions | | | Hex ① | Hex ② | Hex ③ |
|-----------------------|------------------|--------------|---------|------------------------|------|-------------|-------------|-------------|------------|-----------|------------|
| | | | | | | A | B | C | | | |
| | | | | | | mm (in) | mm (in) | mm (in) | mm (in) | mm (in) | mm (in) |
| FD15-1002-04 | 50-300 psi | 7/16 | 7/16-20 | Male SAE O-ring Thread | 2 | 70.9 (2.79) | 25.4 (1.00) | 33.0 (1.30) | 17.5 (.69) | 9.7 (.38) | 14.2 (.56) |

Dimensions (Male Pipe Thread)

| Part Number Buna-N | Sampling Type | Port Size | Thread | Type | Fig. | Dimensions | | | Hex ① | Hex ② | Hex ③ |
|-----------------------|------------------|--------------|--------|------------------|------|-------------|-------------|-------------|------------|-----------|-------|
| | | | | | | A | B | C | | | |
| | | | | | | mm (in) | mm (in) | mm (in) | mm (in) | mm (in) | |
| FD15-1026-04 | 0-50 psi | 1/4 | 1/4-18 | Male Pipe Thread | 3 | 65.0 (2.56) | 25.4 (1.00) | 33.0 (1.30) | 17.5 (.69) | 9.7 (.38) | - |

Dimensions Male SAE O-ring Thread)

| Part Number Buna-N | Sampling Type | Port Size | Thread | Type | Fig. | Dimensions | | | Hex ① | Hex ② | Hex ③ |
|-----------------------|------------------|--------------|---------|------------------------|------|-------------|-------------|-------------|------------|-----------|------------|
| | | | | | | A | B | C | | | |
| | | | | | | mm (in) | mm (in) | mm (in) | mm (in) | mm (in) | |
| FD15-1025-04 | 0-50 psi | 7/16 | 7/16-20 | Male SAE O-ring Thread | 4 | 70.9 (2.79) | 25.4 (1.00) | 33.0 (1.30) | 17.5 (.69) | 9.7 (.38) | 14.2 (.56) |

Male Pipe Thread 0-50 psi

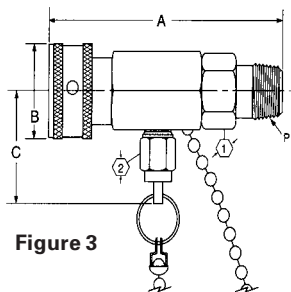

Figure 3

Male SAE O-ring Thread 0-50 psi

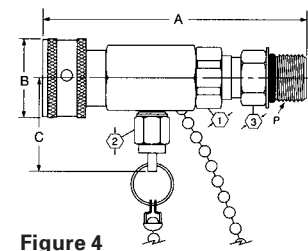

Figure 4

FD90 Series

Diagnostic Coupling
SAE J1502 Interchange



The FD90 Series diagnostic coupling is designed to connect and disconnect pressure gauges to hydraulic systems, eliminating the need for permanent gauges. The maximum operating pressure is 7,000 psi.

Product Features

- Automatic sleeve for one hand push-to-connect operation
- Flush face valving provides minimal fluid loss and low air inclusion
- Self-sealing valve design allows connection and disconnection at 500 psi
- Broad range of end configurations for system accessibility
- Standard seal material – Buna-N
- Standard seal material – High resistance carbon steel with zinc trivalent plating

Applications

- Diagnostic pressure testing for hydraulic systems



DIAGNOSTICS

Physical Characteristics

| Coupling Size | Max. Operating Pressure | | Min. Burst Pressure Connected | | Vacuum Connected Only | Rated Flow | | Air Inclusion | Fluid Loss |
|---------------|-------------------------|---------|-------------------------------|----------|-----------------------|------------|-------|---------------|------------|
| | bar | (psi) | bar | (psi) | (in./Hg) | L/min | (gpm) | cc. max. | cc.max. |
| 1/4 | 483 | (7,000) | 1,931 | (28,000) | 28 | 1.89 | (0.6) | 0.02 | 0.10 |

Dimensions (Female Pipe, Valved)

| Part Number Buna-N | Part Number with Dust Cap Buna-N | Coupling Type | Coupling Size | Body Size | Port Size | Thread | Type | Fig. | Dimensions | | | | | |
|--------------------|----------------------------------|---------------|---------------|-----------|-----------|----------|------------|------|------------|--------|------|--------|------|--------|
| | | | | | | | | | Fig. A | B | | Hex ① | | |
| | | | | | | | | | mm | (in) | mm | (in) | mm | (in) |
| FD90-1034-02-04 | FD90-1035-02-04 | Male | -04 | 1/4 | 1/8 | 1/8 - 27 | Female NPT | 1 | 43.2 | (1.70) | - | - | 15.7 | (0.62) |
| FD90-1021-02-04 | - | Female | -04 | 1/4 | 1/8 | 1/8 - 27 | Female NPT | 2 | 49.5 | (1.95) | 25.4 | (1.00) | 19.1 | (0.75) |
| FD90-1034-04-04 | FD90-1035-04-04 | Male | -04 | 1/4 | 1/4 | 1/4 - 18 | Female NPT | 1 | 48.3 | (1.90) | - | - | 19.1 | (0.75) |
| FD90-1021-04-04 | - | Female | -04 | 1/4 | 1/4 | 1/4 - 18 | Female NPT | 2 | 57.2 | (2.25) | 25.4 | (1.00) | 19.1 | (0.75) |

Dimensions (Male SAE O-ring, Valved)

| Part Number Buna-N | Part Number with Dust Cap Buna-N | Coupling Type | Coupling Size | Body Size | Port Size | Thread | Type | Fig. | Dimensions | | | | | |
|--------------------|----------------------------------|---------------|---------------|-----------|-----------|-----------|-----------------|------|------------|--------|----|-------|------|--------|
| | | | | | | | | | Fig. A | B | | Hex ① | | |
| | | | | | | | | | mm | (in) | mm | (in) | mm | (in) |
| FD90-1044-03-04 | FD90-1004-03-04 | Male | -04 | 1/4 | 3/8 | 3/8 - 24 | Male SAE O-ring | 3 | 38.6 | (1.52) | - | - | 15.7 | (0.62) |
| FD90-1044-04-04 | FD90-1004-04-04 | Male | -04 | 1/4 | 7/16 | 7/16 - 20 | Male SAE O-ring | 3 | 40.1 | (1.58) | - | - | 15.7 | (0.62) |
| FD90-1044-05-04 | FD90-1004-05-04 | Male | -04 | 1/4 | 1/2 | 1/2 - 20 | Male SAE O-ring | 3 | 33.5 | (1.32) | - | - | 15.7 | (0.62) |
| FD90-1044-06-04 | FD90-1004-06-04 | Male | -04 | 1/4 | 9/16 | 9/16 - 18 | Male SAE O-ring | 3 | 33.5 | (1.32) | - | - | 17.5 | (0.69) |

Dimensions (Male Pipe, Valved)

| Part Number Buna-N | Part Number with Dust Cap Buna-N | Coupling Type | Coupling Size | Body Size | Port Size | Thread | Type | Fig. | Dimensions | | | | | |
|--------------------|----------------------------------|---------------|---------------|-----------|-----------|----------|----------|------|------------|--------|----|-------|------|--------|
| | | | | | | | | | Fig. A | B | | Hex ① | | |
| | | | | | | | | | mm | (in) | mm | (in) | mm | (in) |
| FD90-1012-02-04 | FD90-1045-02-04 | Male | -04 | 1/4 | 1/8 | 1/8 - 27 | Male NPT | 4 | 40.6 | (1.60) | - | - | 15.7 | (0.62) |
| FD90-1012-04-04 | FD90-1045-04-04 | Male | -04 | 1/4 | 1/4 | 1/4 - 18 | Male NPT | 4 | 37.8 | (1.49) | - | - | 17.5 | (0.69) |

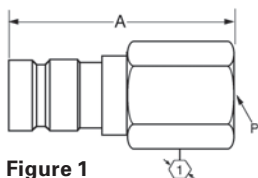

Figure 1

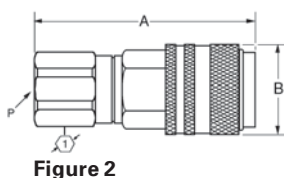

Figure 2

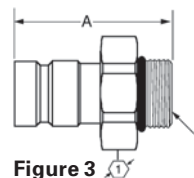

Figure 3

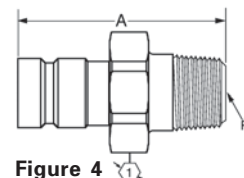

Figure 4

FD90 Series

Diagnostic Coupling
SAE J1502 Interchange

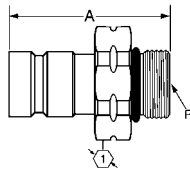

Figure 5

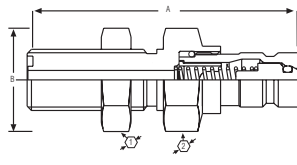

Figure 6

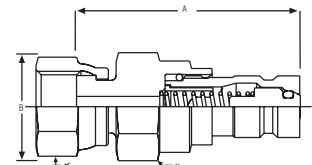

Figure 7

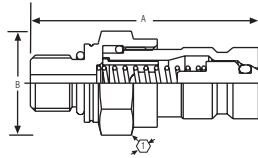

Figure 8

Dimensions (Metric Male O-ring, Valved)

| Part Number Buna-N | Part Number with Dust Cap Buna-N | Coupling Type | Coupling Size | Body Size | Port Size | Thread | Type | Fig. | Dimensions | | | | | |
|-----------------------|--|------------------|------------------|--------------|--------------|---------|-------------|---------|------------|---------|---|---------|-------|--------|
| | | | | | | | | | A | | B | | Hex ① | |
| | | | | | | | | mm (in) | | mm (in) | | mm (in) | | |
| FD90-1046-06-04 | FD90-1047-06-04 | Male | -04 | 1/4 | M14 | M14x1.5 | Male O-ring | 5 | 38.5 | (1.52) | - | - | 19.1 | (0.75) |

Dimensions (Female SAE O-ring, Valved)

| Part Number Buna-N | Coupling Type | Coupling Size | Body Size | Port Size | Thread | Type | Fig. | Dimensions | | | | | |
|-----------------------|------------------|------------------|--------------|--------------|-----------|-------------------|------|------------|--------|---------|--------|---------|--------|
| | | | | | | | | A | | B | | Hex ① | |
| | | | | | | | | mm (in) | | mm (in) | | mm (in) | |
| FD90-1041-09-04 | Female | -04 | 1/4 | 7/16 | 7/16 - 20 | Female SAE O-ring | 2 | 55.9 | (2.20) | 25.40 | (1.00) | 19.1 | (0.75) |

Dimensions (Male ORS Bulkhead, Valved)

| Part Number Buna-N | Coupling Type | Coupling Size | Body Size | Port Size | Thread | Type | Fig. | Dimensions | | | | | |
|-----------------------|------------------|------------------|--------------|--------------|-----------|-------------------|------|------------|--------|---------|--------|---------|--------|
| | | | | | | | | A | | B | | Hex ① | |
| | | | | | | | | mm (in) | | mm (in) | | mm (in) | |
| FD90-1206-04-04 | Male | -04 | 1/4 | 9/16 | 9/16 - 18 | Male ORS Bulkhead | 6 | 62.5 | (2.46) | 20.6 | (0.81) | 20.6 | (0.81) |

Dimensions (Male ORS Bulkhead, Valved)

| Part Number Buna-N | Coupling Type | Coupling Size | Body Size | Port Size | Thread | Type | Fig. | Dimensions | | | | | |
|-----------------------|------------------|------------------|--------------|--------------|------------|-------------------|------|------------|--------|---------|--------|---------|--------|
| | | | | | | | | A | | B | | Hex ① | |
| | | | | | | | | mm (in) | | mm (in) | | mm (in) | |
| FD90-1061-04-04 | Male | -04 | 1/4 | 9/16 | 9/16 - 18 | Female ORS Swivel | 7 | 46.5 | (1.79) | 22.1 | (0.87) | 17.5 | (0.69) |
| FD90-1061-06-04 | Male | -04 | 1/4 | 11/16 | 11/16 - 16 | Female ORS Swivel | 7 | 46.5 | (1.83) | 23.9 | (0.94) | 20.6 | (0.81) |
| FD90-1061-08-04 | Male | -04 | 1/4 | 13/16 | 13/16 - 16 | Female ORS Swivel | 7 | 49.0 | (1.93) | 27.4 | (1.08) | 23.9 | (0.94) |

Dimensions (Male Metric O-ring, Valved)

| Part Number Buna-N | Coupling Type | Coupling Size | Body Size | Port Size | Thread | Type | Fig. | Dimensions | | | | | |
|-----------------------|------------------|------------------|--------------|--------------|--------|---------------|------|------------|--------|---------|--------|---------|---|
| | | | | | | | | A | | B | | Hex ① | |
| | | | | | | | | mm (in) | | mm (in) | | mm (in) | |
| FD90-1090-10-04 | Male | -04 | 1/4 | M10 | M10x1 | Mertic O-ring | 8 | 40.1 | (1.58) | 18.3 | (0.72) | - | - |

Dust Cap for Male Halves

| Coupling Size | Part Number |
|---------------|-----------------|
| -04 | FD90-1040-04-04 |



Dust Cap for
Male Halves

Pressure Gauge Kit

FF14802



The Eaton pressure gauge kit and screw together test couplings provide accurate and efficient pressure control and monitoring of your hydraulic system, while minimizing the introduction of contamination. The complete kit is pre-packaged with Eaton's most common adapters and test couplings.

Product Features

- Test system at working pressure
- 630 bar (9,000 psi) working pressure
- 345 bar (5,000 psi) connect under pressure
- Accurate pressure control and system monitoring

Couplings/Adapters

- Standard body material – Zinc Nickel Plated Steel
- Standard seal material – Viton
- 345 bar (5,000 psi) connect under pressure
- 630 bar (9,000 psi) working pressure

Hose Assemblies

- 630 bar (9,000 psi) working pressure
- 20mm (.75") bend radius
- Nominal Bore 2mm (.08")
- Hose cover/core – PA 11/12
- Reinforcement – synthetic fiber

- Leak-free connection before piston valve opens
- Simple and fast screw together connections
- Self-locking caps

Applications

- Hydraulics and mineral based fluids
- Agricultural equipment
- Construction equipment
- On-Highway vehicles
- Industrial equipment

Gauges

- Polished Brass Casing
- Glycerine Filled
- Dual Scales
- Relief Valve
- Acrylic Lens

Pressure Gauge Kit

| Complete Kit Number | Component Part Number | Description | Quantity Per Kit |
|---------------------|-----------------------|---------------------------|------------------|
| FF14802 | FF14783 | 1/8" NPT Test Coupling | 2 |
| | FF14784 | 1/4" NPT Test Coupling | 2 |
| | FF14787 | 7/16-20 UNF Test Coupling | 1 |
| | FF14788 | 9/16-20 UNF Test Coupling | 1 |
| | FF14794 | 1/4" NPT Gauge Adapter | 3 |

| Complete Kit Number | Component Part Number | Description | Quantity Per Kit |
|---------------------|-----------------------|-----------------------------|------------------|
| | FF14796 | Union Adapter | 2 |
| | FF14798 | 60" Test Hose Assembly | 2 |
| | FF14799 | (-) 30 in/Hg - 30 psi Gauge | 1 |
| | FF14800 | 1,000 psi Gauge | 1 |
| | FF14801 | 7,500 psi Gauge | 1 |

Dimensions (Standard Test Couplings)

| Part Number | Thread | Dimensions A | | B | | Hex ① | | Bag Quantity* |
|-------------|-------------|--------------|--------|------|-------|-------|-------|---------------|
| | | mm | (in) | mm | (in) | mm | (in) | |
| FF14783 | 1/8" NPT | 45.0 | (1.77) | 20.0 | (.79) | 17.0 | (.67) | 4 |
| FF14784 | 1/4" NPT | 50.0 | (1.97) | 20.0 | (.79) | 17.0 | (.67) | 4 |
| FF14785 | M14 | 49.0 | (1.93) | 20.0 | (.79) | 19.0 | (.75) | 3 |
| FF14786 | M16 | 48.5 | (1.91) | 20.0 | (.79) | 22.0 | (.87) | 3 |
| FF14787 | 7/16-20 UNF | 47.0 | (1.85) | 20.0 | (.79) | 17.0 | (.67) | 4 |
| FF14788 | 9/16-20 UNF | 47.5 | (1.87) | 20.0 | (.79) | 19.0 | (.75) | 4 |

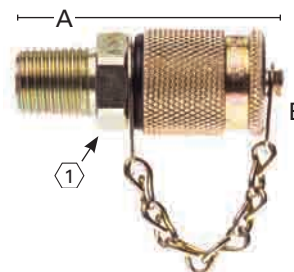

Standard Test Couplings

*When the indicated part number is ordered, the bag quantity is the number of pieces supplied. For example, if a quantity of one FF14792 is ordered, one bag containing two pieces will be delivered.

Dimensions (Bulkhead Couplings)

| Part Number | Thread | Dimensions | | | | Hex ① | | Hex ② | | Bag Quantity* |
|-------------|--------|------------|------|------|------|-------|------|-------|------|---------------|
| | | A | | B | | | | | | |
| | | mm | (in) | mm | (in) | mm | (in) | mm | (in) | |
| FF14789 | M16 | 72.0 | 2.83 | 20.0 | .79 | 17.0 | .67 | 19.0 | .75 | 2 |

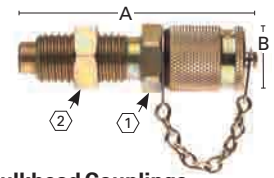

Bulkhead Couplings

Dimensions (Swivel Run Tee with Test Coupling)

| Part Number | Thread #1 | Thread #2 | Dimensions | | | | Hex ① | | Bag Quantity* |
|-------------|-------------|-------------|------------|--------|------|-------|-------|--------|---------------|
| | | | A | | B | | | | |
| | | | mm | (in) | mm | (in) | mm | (in) | |
| FF14790 | 7/16-20 UNF | 7/16-20 UNF | 47.7 | (1.88) | 20.0 | (.79) | 27.0 | (1.06) | 2 |
| FF14791 | 9/16-18 UNF | 9/16-18 UNF | 47.7 | (1.88) | 20.0 | (.79) | 27.0 | (1.06) | 2 |
| FF14792 | 3/4-16 UNF | 3/4-16 UNF | 47.7 | (1.88) | 20.0 | (.79) | 27.0 | (1.06) | 2 |

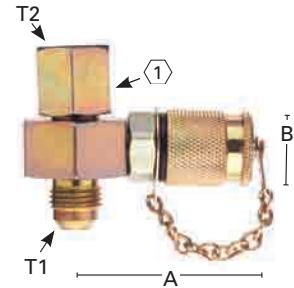

Swivel Run Tee with Test Coupling

Dimensions (Gauge Adapter)

| Part Number | Thread #1 | Thread #2 | Dimensions | | | | Hex ① | | Hex ② | | Bag Quantity* |
|-------------|-----------|-----------|------------|--------|------|-------|-------|-------|-------|------|---------------|
| | | | A | | B | | | | | | |
| | | | mm | (in) | mm | (in) | mm | (in) | mm | (in) | |
| FF14793 | 1/4" NPT | M16 | 54.0 | (2.13) | 19.0 | (.75) | 19.0 | (.75) | 2 | | |

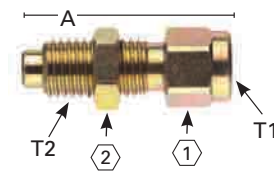

Gauge Adapter

Dimensions (Direct Gauge Adapter)

| Part Number | Thread | Dimensions | | | | Hex ① | | Bag Quantity* |
|-------------|-------------|------------|--------|------|-------|-------|-------|---------------|
| | | A | | B | | | | |
| | | mm | (in) | mm | (in) | mm | (in) | |
| FF14794 | 1/4" NPT | 40.5 | (1.59) | 20.0 | (.79) | 19.0 | (.75) | 2 |
| FF14795 | 7/16-20 UNF | 41.0 | (1.61) | 20.0 | (.79) | 19.0 | (.75) | 2 |

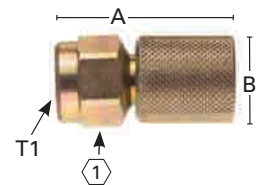

Direct Gauge Adapter

Dimensions (Union Adapter)

| Part Number | Thread #1 | Thread #2 | Dimensions | | | | Bag Quantity* |
|-------------|-----------|-----------|------------|--------|-------|-------|---------------|
| | | | A | | Hex ① | | |
| | | | mm | (in) | mm | (in) | |
| FF14796 | M16 | M16 | 42.5 | (1.67) | 17.0 | (.67) | 2 |

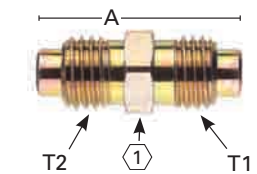

Union Adapter

Dimensions (Test Hose Assembly)

| Part Number | Thread | Dimensions | | | Bag Quantity* | |
|-------------|--------|------------|----------------|--------|---------------|----|
| | | Cut Length | Overall Length | | | |
| | | | mm | (in) | | mm |
| FF14797 | M16 | 872.0 | (34.33) | 914.4 | (36.00) | 1 |
| FF14798 | M16 | 1482.0 | (58.35) | 1524.0 | (60.00) | 1 |



Test Hose Assembly

Dimensions (Gauges)

| Part Number | Thread | Dimensions | | | | Rating | Bag Quantity* |
|-------------|----------|------------|--------|------|--------|----------------------|---------------|
| | | A | | B | | | |
| | | mm | (in) | mm | (in) | | |
| FF14799 | 1/4" NPT | 65.3 | (2.57) | 53.3 | (2.10) | (-)30 in/Hg - 30 psi | 1 |
| FF14800 | 1/4" NPT | 65.3 | (2.57) | 53.3 | (2.10) | 0 - 1,000 psi | 1 |
| FF14801 | 1/4" NPT | 65.3 | (2.57) | 53.3 | (2.10) | 0 - 7,500 psi | 1 |

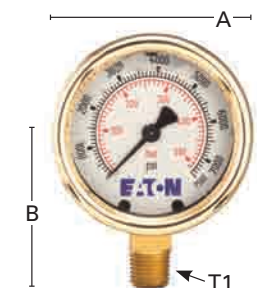

Gauges

*When the indicated part number is ordered, the bag quantity is the number of pieces supplied.
For example, if a quantity of one FF14792 is ordered, one bag containing two pieces will be delivered.

FD14 Series

Oil Drain Coupling



The FD14 Drain coupling is designed to serve as a drain port for use with Eaton’s FLOCS (Fast Lube Oil Change System) as well as providing a purging port for use during pre-fill operations. The FD14 provides a leak free push to connect operation for improving speed and efficiency for oil evacuation systems.

Product Features

- Low-Profile design with multiple sealing mechanisms
- Push-To-Connect female half for easy one-hand operation
- Broad range of standard thread styles for Male Half
- Utilizes a Copper-Crush gasket to seat against the port face
- Standard male half seal material - Viton
- Standard female half seal material - Buna-N
- Standard body material - High resistance carbon steel with zinc trivalent chromate plating with zinc die-cast valve

Physical Characteristics

| Body Size | Max. Operating Pressure | | Min. Burst Pressure Connected | | Vacuum Connected Only | Rated Flow |
|-----------|-------------------------|-------|-------------------------------|-------|-----------------------|-------------|
| | bar | (psi) | bar | (psi) | (in./Hg) | L/min (gpm) |
| 3/8 | 3.5 | (50) | 7.0 | (200) | 28 | 12 (3) |



Applications

- Automated oil evacuation systems
- Gravity drain oil evacuation systems

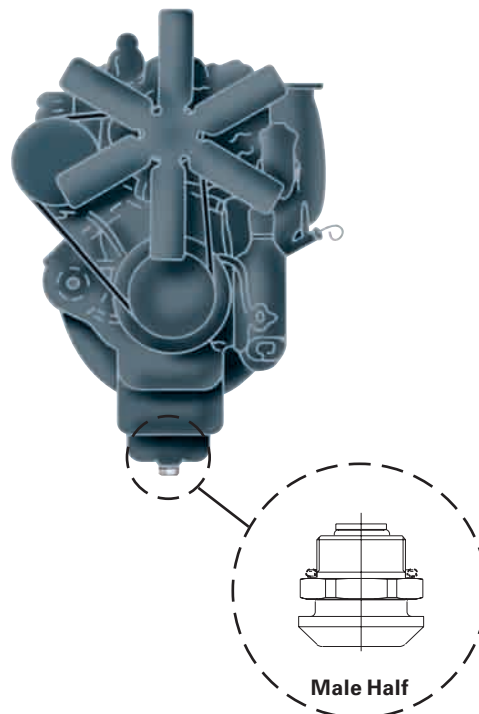

FD14 Series

Oil Drain Coupling

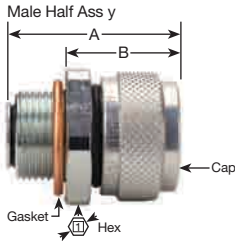

Figure 1

Dimensions (English Thread)

| Body Size | Thread Size | Fig. | Dimensions | | | | Hex ① | | Min. Assy. Torque | | Part Number Assembly (includes Gasket & Cap) | Gasket (Copper-Crush) | Cap (Brass) |
|-----------|---------------------|------|------------|--------|------|-------|-------|----------|-------------------|----------|--|-----------------------|--------------|
| | | | A | B | P | P | mm | (in) | N-m | (lbs-ft) | | | |
| 3/8 | 1 1/16-12 UN-2A | 1 | 39.1 | (1.54) | 24.4 | (.96) | 38.1 | (1 1/2) | 41-81 | (30-60)* | FD14-4002-20-06 | FD14-1206-08 | FD14-1210-06 |
| 3/8 | 1 1/4-18 UNEF-2A | 1 | 39.1 | (1.54) | 24.4 | (.96) | 38.1 | (1 1/2) | 41-81 | (30-60)* | FD14-4002-05-06 | FD14-1206-11 | FD14-1210-06 |
| 3/8 | 1 1/8-12 UNF-2A | 1 | 39.1 | (1.54) | 24.4 | (.96) | 38.1 | (1 1/2) | 41-81 | (30-60)* | FD14-4002-14-06 | FD14-1206-09 | FD14-1210-06 |
| 3/8 | 1/2-14 DRYSEAL NPTF | 1 | 40.6 | (1.60) | 24.4 | (.96) | 27.0 | (1 1/16) | - | - | FD14-4002-27-06* | None Needed | FD14-1210-06 |
| 3/8 | 1/2-14 UNS-2A | 1 | 38.6 | (1.52) | 24.4 | (.96) | 27.0 | (1 1/16) | 27-33 | (20-24)* | FD14-4002-22-06* | FD14-1206-01 | FD14-1210-06 |
| 3/8 | 1/2-20 UNF-2A | 1 | 38.6 | (1.52) | 24.4 | (.96) | 27.0 | (1 1/16) | 27-33 | (20-24)* | FD14-4002-01-06* | FD14-1206-01 | FD14-1210-06 |
| 3/8 | 1-18 UNS-2A | 1 | 39.1 | (1.54) | 24.4 | (.96) | 31.8 | (1 1/4) | 41-81 | (30-60)* | FD14-4002-06-06 | FD14-1206-07 | FD14-1210-06 |
| 3/8 | 3/4-14 DRYSEAL NPTF | 1 | 43.8 | (1.72) | 24.4 | (.96) | 31.8 | (1 1/4) | - | - | FD14-4002-26-06 | None Needed | FD14-1210-06 |
| 3/8 | 3/4-16 UNF-2A | 1 | 39.1 | (1.54) | 24.4 | (.96) | 31.8 | (1 1/4) | 41-68 | (30-50)* | FD14-4002-09-06 | FD14-1206-04 | FD14-1210-06 |
| 3/8 | 5/8-18 UNF-2A | 1 | 38.6 | (1.52) | 24.4 | (.96) | 27.0 | (1 1/16) | 27-54 | (20-40)* | FD14-4002-08-06* | FD14-1206-03 | FD14-1210-06 |
| 3/8 | 7/8-14 UNF-2A | 1 | 39.1 | (1.54) | 24.4 | (.96) | 31.8 | (1 1/4) | 41-81 | (30-60)* | FD14-4002-10-06 | FD14-1206-06 | FD14-1210-06 |
| 3/8 | 7/8-18 UNS-2A | 1 | 39.1 | (1.54) | 24.4 | (.96) | 31.8 | (1 1/4) | 41-81 | (30-60)* | FD14-4002-07-06 | FD14-1206-06 | FD14-1210-06 |
| 3/8 | 9/16-18 UNF-2A | 1 | 38.6 | (1.52) | 24.4 | (.96) | 27.0 | (1 1/16) | 27-54 | (20-40)* | FD14-4002-12-06* | FD14-1206-02 | FD14-1210-06 |

*⚠CAUTION: Failure to meet minimum assembly torque could result in fluid leakage.

Dimensions (Metric Thread)

| Body Size | Thread Size | Fig. | Dimensions | | | | Hex ① | | Min. Assy. Torque | | Part Number Assembly (includes Gasket & Cap) | Gasket (Copper-Crush) | Cap (Brass) |
|-----------|---------------|------|------------|--------|------|-------|-------|----------|-------------------|----------|--|-----------------------|--------------|
| | | | A | B | P | P | mm | (in) | N-m | (lbs-ft) | | | |
| 3/8 | M12 X 1.5 6g | 1 | 38.6 | (1.52) | 24.4 | (.96) | 27.0 | (1 1/16) | 27-33 | (20-24)* | FD14-4002-23-06* | FD14-1206-01 | FD14-1210-06 |
| 3/8 | M12 X 1.75 6g | 1 | 38.6 | (1.52) | 24.4 | (.96) | 27.0 | (1 1/16) | 27-33 | (20-24)* | FD14-4002-25-06* | FD14-1206-01 | FD14-1210-06 |
| 3/8 | M14 X 1.25 6g | 1 | 38.6 | (1.52) | 24.4 | (.96) | 27.0 | (1 1/16) | 27-33 | (20-24)* | FD14-4002-03-06* | FD14-1206-02 | FD14-1210-06 |
| 3/8 | M14 X 1.5 6g | 1 | 38.6 | (1.52) | 24.4 | (.96) | 27.0 | (1 1/16) | 27-33 | (20-24)* | FD14-4002-24-06* | FD14-1206-02 | FD14-1210-06 |
| 3/8 | M18 X 1.5 6g | 1 | 38.6 | (1.52) | 24.4 | (.96) | 31.8 | (1 1/4) | 27-33 | (20-24)* | FD14-4002-02-06* | FD14-1206-04 | FD14-1210-06 |
| 3/8 | M20 X 1.5 6g | 1 | 39.1 | (1.54) | 24.4 | (.96) | 31.8 | (1 1/4) | 41-81 | (30-60)* | FD14-4002-16-06 | FD14-1206-05 | FD14-1210-06 |
| 3/8 | M22 X 1.5 6g | 1 | 39.1 | (1.54) | 24.4 | (.96) | 31.8 | (1 1/4) | 41-81 | (30-60)* | FD14-4002-18-06 | FD14-1206-06 | FD14-1210-06 |
| 3/8 | M24 X 1.5 6g | 1 | 39.1 | (1.54) | 24.4 | (.96) | 31.8 | (1 1/4) | 41-81 | (30-60)* | FD14-4002-19-06 | FD14-1206-07 | FD14-1210-06 |
| 3/8 | M24 X 2 6g | 1 | 39.1 | (1.54) | 24.4 | (.96) | 31.8 | (1 1/4) | 41-81 | (30-60)* | FD14-4002-11-06 | FD14-1206-07 | FD14-1210-06 |
| 3/8 | M25 X 1.5 6g | 1 | 39.1 | (1.54) | 24.4 | (.96) | 31.8 | (1 1/4) | 41-81 | (30-60)* | FD14-4002-17-06 | FD14-1206-07 | FD14-1210-06 |
| 3/8 | M27 X 2 6g | 1 | 36.3 | (1.43) | 24.4 | (.96) | 38.1 | (1 1/2) | 41-81 | (30-60)* | FD14-4002-29-06 | FD14-1206-06 | FD14-1210-06 |
| 3/8 | M30 X 1.5 6g | 1 | 39.1 | (1.54) | 24.4 | (.96) | 38.1 | (1 1/2) | 41-81 | (30-60)* | FD14-4002-21-06 | FD14-1206-10 | FD14-1210-06 |

*⚠CAUTION: Failure to meet minimum assembly torque could result in fluid leakage.

Dimensions (Female Half NPTF, Valved)

| Body Size | Thread Size | Fig. | Dimensions | | | | Hex ① | Part Number Assembly |
|-----------|---------------------|------|------------|--------|------|--------|---------------|----------------------|
| | | | A | B | P | P | | |
| 3/8 | 3/4-14 Dryseal NPTF | 2 | 46.5 | (1.83) | 45.7 | (1.80) | 33.0 (1 5/16) | FD14-1001-12-06 |

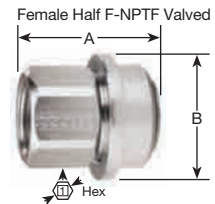

Figure 2

Dimensions (Female Half Assembly, Non-Valved)

| Body Size | Hose Size | Fig. | Dimensions | | Part Number Assembly |
|-----------|------------------|------|-------------|-------------|----------------------|
| | | | A | B | |
| 3/8 | 5/8" SOCKETLESS™ | 3 | 59.4 (2.34) | 38.1 (1.50) | FD14-4003-10-06 |

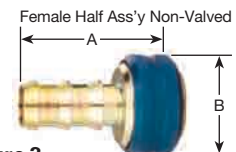

Figure 3

FD14 Series

Oil Drain Coupling

Dimensions (Cap Molded Rubber)

| Body Size | Fig. | Dimensions A | | Dimensions B | | Part Number Cap (Buna-N) |
|-----------|------|--------------|--------|--------------|--------|--------------------------|
| | | mm | (in) | mm | (in) | |
| 3/8 | 4 | 13.2 | (.519) | 35.6 | (1.40) | FD14-1204-06 |

Dimensions (Cap)

| Body Size | Fig. | Dimensions A | | Dimensions B | | Part Number Cap (Buna-N) |
|-----------|------|--------------|--------|--------------|--------|--------------------------|
| | | mm | (in) | mm | (in) | |
| 3/8 | 5 | 18.4 | (.726) | 31.8 | (1.25) | FD14-1210-06 |

Swivel Joint

| Body Size | Fig. | Thread Size | Cap | Part Number (Buna-N) |
|-----------|------|-------------|--------------|----------------------|
| | | | | |
| 3/8 | 6 | 3/4-14 | Dryseal NPTF | FD14-1004-12-12 |

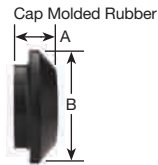

Figure 4

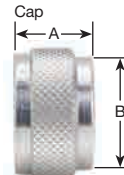

Figure 5



Figure 6



SPECIAL APPLICATIONS

FD31 Series

Enerpac Interchange



The FD31 Series Hydraulic Jack/Enerpac Interchange is designed for high pressure applications up to 700 bar (10,000 psi). The Eaton FD31 interchanges with the Parker® 3,000 Series Coupling.

Product Features

- Thread together design
- Seal material – Nitrile
- 700 bar (10,000 psi) operating pressure
- Body material – High resistance carbon steel with zinc trivalent chromate plating

Applications

- Hydraulic jack
- Portable hydraulic rams



Physical Characteristics

| Body Size | Max. Operating Pressure (Static) | | Min. Burst Pressure | | Rated Flow |
|-----------|----------------------------------|----------|---------------------|----------|-------------|
| | Connected | | Connected | | |
| | bar | (psi) | bar | (psi) | L/min (gpm) |
| 1/4 | 700 | (10,000) | 2,200 | (31,900) | 12 (3) |
| 3/8 | 700 | (10,000) | 18,50 | (26,800) | 23 (6) |

* Connect and disconnect under pressure not allowed

Dimensions

| Part Number | Coupling Type | Body Size | Port Size | Thread | Type | Fig. | Dimensions | | | | | |
|-----------------|---------------|-----------|-----------|--------|------------|------|------------|--------|------|--------|-------|------|
| | | | | | | | A | | B | | Hex ① | |
| | | | | | | | mm | (in) | mm | (in) | mm | (in) |
| FD31-1001-04-04 | Female | 1/4 | 1/4 | 1/4-18 | Male NPT | 1 | 60,8 | (2.39) | 28,0 | (1.10) | 22 | .87 |
| FD31-1002-04-04 | Male | 1/4 | 1/4 | 1/4-18 | Female NPT | 2 | 32,5 | (1.28) | 28,0 | (1.10) | 19 | .75 |
| FD31-1001-06-06 | Female | 3/8 | 3/8 | 3/8-18 | Male NPT | 1 | 72,2 | (2.84) | 35,0 | (1.38) | 24 | .94 |
| FD31-1002-06-06 | Male | 3/8 | 3/8 | 3/8-18 | Female NPT | 2 | 40,0 | (1.57) | 35,0 | (1.38) | 32 | 1.26 |

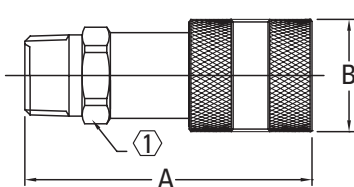

Figure 1

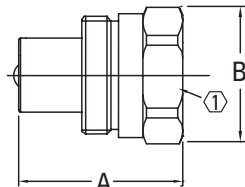

Figure 2

Dust Caps and Dust Plugs

| Coupling Size | Part Number | Coupling Type | Cap Material |
|---------------|--------------|---------------|--------------|
| 1/4 | FD31-1005-04 | Female | Aluminum |
| 3/8 | FD31-1005-06 | Female | Aluminum |

| Coupling Size | Part Number | Coupling Type | Cap Material |
|---------------|--------------|---------------|--------------|
| 1/4 | FD31-1004-04 | Male | Aluminum |
| 3/8 | FD31-1004-06 | Male | Aluminum |

FD69 Series

10,000 psi Water Blast



The FD69 Series “Arc Latch™” design has a greater surface contact area for long service life in rugged high pressure and water blast applications. The maximum operating pressure is 10,000 psi with 40,000 psi minimum burst pressure.

Product Features

- Safety sleeve lock guards against accidental disconnection
- Smooth bore “straight through” design for high flow fluid requirements
- Heavy duty back-up ring to prevent O-ring extrusion
- Available in plated steel and stainless steel for added corrosion resistance
- Standard seal material – Buna-N
- Standard body material – High resistance carbon steel with zinc trivalent plating or stainless steel

Physical Characteristics

| Coupling Size | Max. Operating Pressure | | Min. Burst Pressure Connected | | Vacuum Connected Only | Rated Flow | | Air Inclusion | Fluid Loss |
|---------------|-------------------------|----------|-------------------------------|----------|-----------------------|------------|-------|---------------|------------|
| | bar | (psi) | bar | (psi) | (in./Hg) | L/min | (gpm) | cc. max. | cc.max. |
| 3/8 | 689 | (10,000) | 2,758 | (40,000) | 28 | 170 | (45) | - | - |



Applications

- High pressure water blast
- Bridge/concrete repair
- Paint stripping
- Shipyards

Flow Data

Pressure Drop Versus Flow Graph

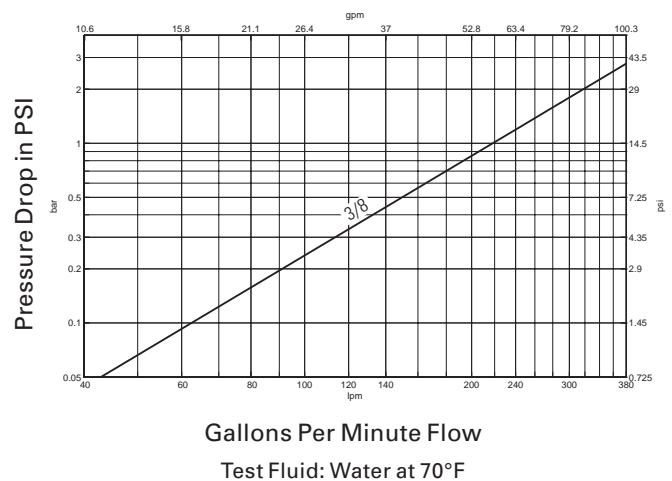

FD69 Series

10,000 psi Water Blast

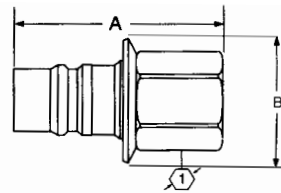

Figure 1

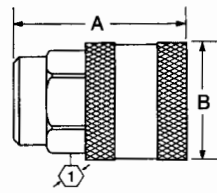

Figure 2

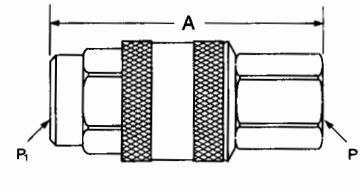

Figure 3

Dimensions (Female NPT)

| Part Number | Buna-N | Viton | EPR | Coupling Type | Body Size | Port Size | Thread | Type | Fig. | Dimensions | | Hex ① | | | |
|------------------------|-----------------|-----------------|-----------------|---------------|-----------|-----------|--------|------------|------|------------|--------|-------|--------|------|--------|
| | | | | | | | | | | A | B | mm | (in) | | |
| FD69-1002-06-08 | FD69-1002-06-08 | FD69-1002-06-08 | FD69-1002-06-08 | Male* | 1/2 | 3/8 | 3/8-18 | Female NPT | 1 | 47.0 | (1.85) | 41.7 | (1.64) | 25.4 | (1.00) |
| FD69-1001-06-08 | FD69-1026-06-08 | FD69-1028-06-08 | FD69-1028-06-08 | Female | 1/2 | 3/8 | 3/8-18 | Female NPT | 2 | 54.1 | (2.13) | 41.1 | (1.62) | 31.8 | (1.25) |
| FD69-1002-08-08 | FD69-1002-08-08 | FD69-1002-08-08 | FD69-1002-08-08 | Male* | 1/2 | 1/2 | 1/2-14 | Female NPT | 1 | 59.4 | (2.34) | 41.7 | (1.64) | 28.4 | (1.12) |
| FD69-1001-08-08 | FD69-1026-08-08 | FD69-1028-08-08 | FD69-1028-08-08 | Female | 1/2 | 1/2 | 1/2-14 | Female NPT | 2 | 54.1 | (2.13) | 41.1 | (1.62) | 31.8 | (1.25) |
| Stainless Steel | | | | | | | | | | | | | | | |
| FD69-1012-08-08 | FD69-1012-08-08 | FD69-1012-08-08 | FD69-1012-08-08 | Male* | 1/2 | 1/2 | 1/2-14 | Female NPT | 1 | 59.4 | (2.34) | 41.7 | (1.64) | 28.4 | (1.12) |
| FD69-1011-08-08 | - | - | - | Female | 1/2 | 1/2 | 1/2-14 | Female NPT | 2 | 54.1 | (2.13) | 41.1 | (1.62) | 33.3 | (1.31) |

*Male halves contain no seals.

| Part Number | Buna-N | Viton | EPR | Coupling Type | Body Size | Port Size | Thread | | Type | Fig. | Dimensions | |
|------------------------|------------------|------------------|------------------|---------------|-----------|-----------|--------|--------|------------|------|------------|--------|
| | | | | | | | (P) | (P1) | | | A | (in) |
| FD69-1000-080808 | FD69-1027-080808 | FD69-1029-080808 | FD69-1029-080808 | Complete | 1/2 | 1/2 | 1/2-14 | 1/2-14 | Female NPT | 3 | 87.1 | (3.43) |
| FD69-1000-080806 | FD69-1027-080806 | FD69-1029-080806 | FD69-1029-080806 | Complete | 1/2 | 1/2 & 3/8 | 1/2-14 | 3/8-18 | Female NPT | 3 | 87.1 | (3.43) |
| FD69-1000-060808 | FD69-1027-060808 | FD69-1029-060808 | FD69-1029-060808 | Complete | 1/2 | 3/8 & 1/2 | 3/8-18 | 1/2-14 | Female NPT | 3 | 74.7 | (2.94) |
| FD69-1000-060806 | FD69-1027-060806 | FD69-1029-060806 | FD69-1029-060806 | Complete | 1/2 | 3/8 | 3/8-18 | 3/8-18 | Female NPT | 3 | 74.7 | (2.94) |
| Stainless Steel | | | | | | | | | | | | |
| FD69-1010-080808 | - | - | - | Complete | 1/2 | 1/2 | 1/2-14 | 1/2-14 | Female NPT | 3 | 87.1 | (3.43) |

Repair Kit, Female Interface Seal

| Part Number | Buna-N | Viton | EPR | Coupling Size |
|-------------|--------|-------|-----|---------------|
| FF10166 | - | - | - | 1/2 |

FD83 Series

Full Flow Dual Interlock



The Eaton FD83 is designed for fluid transfer and electronics cooling applications where full flow, fluid compatibility and safety are essential. The FD83 identical halves include two interlock features to eliminate spills and ensure maximum safety. Valves cannot be opened until the coupling halves are mated and coupling halves cannot be disconnected until both halves are closed. The FD83 coupling system can be used in a wide variety of low pressure industrial applications.

Product Features

- Dual interlock safety feature eliminates accidental opening of coupling when disconnected with the use of a patent pending locking pin design and lever handle
- Design provides reliable performance and minimal spillage during maintenance or service
- Standard seal material – EPDM, additional material available on request
- Standard body material – 303 stainless steel, additional material available on request
- Full-flow capability
- Available color coded bumper seals available
- Identical coupling halves
- Maintenance and service friendly
- 303 stainless steel material provides broad fluid compatibility
- 3/4" and 1" Female NPT port threads or hose barb

Physical Characteristics

| Coupling Size | Max. Operating Pressure | | | Min. Burst Pressure | | | Rated Flow L/min (USgpm) | Fluid Loss cc. max |
|---------------|-------------------------|-----------|-------------|---------------------|-----------|-------------|-----------------------------|-----------------------|
| | Connected | Male Half | Female Half | Connected | Male Half | Female Half | | |
| | bar (psi) | bar (psi) | bar (psi) | bar (psi) | bar (psi) | bar (psi) | | |
| 1 | 10 (150) | 10 (150) | 10 (150) | 20 (300) | 20 (300) | 20 (300) | 189 (50) | 5.0 |

Dimensions

| Part Number | Body Size | Port Size | Thread | Type | Fig. | Dimensions | | | | Hex Ⓛ | |
|-----------------|-----------|-----------|----------|--------------|------|------------|--------|------|--------|-------|--------|
| | | | | | | A | | B | | | |
| | | | | | | mm | (in) | mm | (in) | mm | (in) |
| FD83-2052-16-16 | 1 | 1 | 1-11-1/2 | Female NPT | 1 | 95.5 | (3.76) | 71.6 | (2.82) | 41 | (1.63) |
| FD83-2052-12-16 | 1 | 3/4 | 3/4-14 | Female NPT | 1 | 70.1 | (2.76) | 71.6 | (2.83) | 41 | (1.63) |
| FD83-2046-16-16 | 1 | 1 | NA | 1" Hose Barb | 2 | 84.2 | (3.31) | 71.6 | (2.82) | - | - |

Hose barb adapters available upon request.

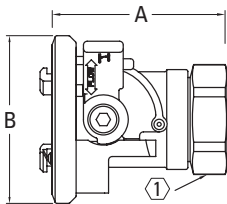

Figure 1

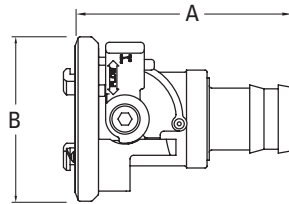
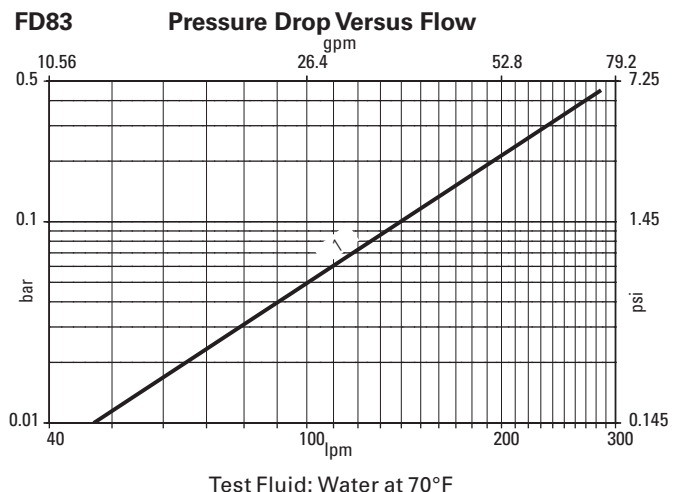

Figure 2

Applications

- Electronics liquid based cooling
- Thermal management systems
- Industrial fluid transfer

Flow Data



5400 Series

Low Air Inclusion Refrigerant



The 5400 Series low air inclusion product line is designed for air conditioning, refrigerant, gaseous and fluid transfer applications.

Product Features

- Brazed or threaded end connections for versatility of installation on tubing or hose
- Tubular valve construction for low fluid loss and air inclusion
- Thread together design allows connection and disconnection against pressure
- Lock washer and jam nut standard for optional bulkhead mounting
- Standard seal material – Neoprene
- Standard adapter material – Steel or Brass
- Standard body material – High resistance carbon steel with zinc trivalent plating

Physical Characteristics

| Coupling Size | Max. Operating Pressure Connected | | Min. Burst Pressure Connected | | Max. Operating Pressure Disconnected | | | | Vacuum Connected Only | | Rated Flow | Air Inclusion | Fluid Loss |
|---------------|-----------------------------------|---------|-------------------------------|---------|--------------------------------------|---------|-----|-------|-----------------------|-------|------------|---------------|------------|
| | bar | (psi) | bar | (psi) | bar | (psi) | bar | (psi) | (in./Hg) | L/min | (gpm) | cc. max. | cc.max. |
| -4 | 207 | (3,000) | 621 | (9,000) | 172 | (2,500) | 34 | (500) | 28 | 8 | (2) | .10 | .05 |
| -8 | 121 | (1,750) | 359 | (5,200) | 121 | (1,750) | 28 | (400) | 28 | 53 | (14) | .10 | .10 |
| -12 | 48 | (700) | 145 | (2,100) | 55 | (800) | 28 | (400) | 28 | 132 | (35) | .30 | .10 |
| -16 | 48 | (700) | 145 | (2,100) | 48 | (700) | 21 | (300) | 28 | 284 | (75) | .50 | .20 |

REFRIGERANT



Applications

- Mobile air conditioning and refrigerant



Flow Data

Pressure Drop Versus Flow Graph

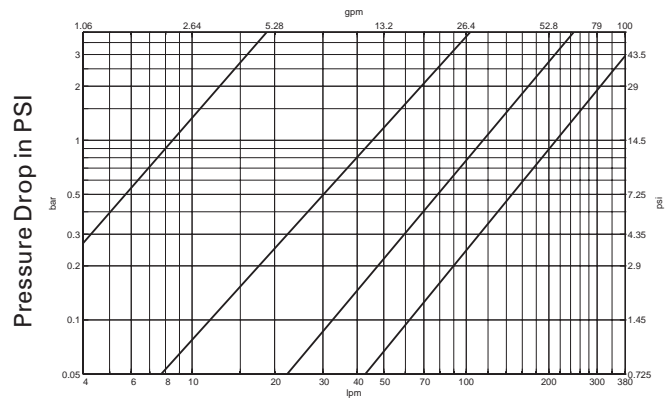

Cubic Feet Per Minute Flow
Test Fluid: Air at 100 PSI Inlet Pressure

5400 Series

Low Air Inclusion Refrigerant

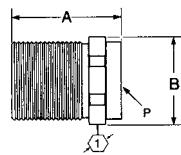

Figure 1

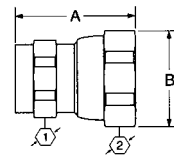

Figure 2

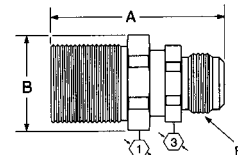

Figure 3

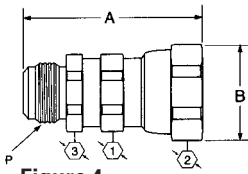

Figure 4

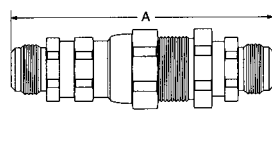

Figure 5

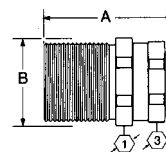

Figure 6

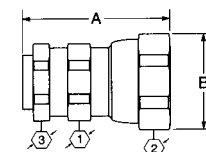

Figure 7

Dimensions – No Adapter

| Part Number Neoprene | Coupling Type | Body Size | Type | Fig. | Dimensions | | Hex ① | | Hex ② | | Hex ③ | | | |
|-------------------------|------------------|--------------|------------|------|------------|--------|-------|--------|-------|--------|-------|--------|----|------|
| | | | | | A | B | mm | (in) | mm | (in) | mm | (in) | mm | (in) |
| 5400-S2-4 | Male | 1/4 | No Adapter | 1 | 27.4 | (1.08) | 21.1 | (.83) | 19.1 | (.75) | - | - | - | - |
| 5400-S5-4 | Female | 1/4 | No Adapter | 2 | 33.3 | (1.31) | 21.1 | (.83) | 16.0 | (.63) | 19.1 | (.75) | - | - |
| 5400-S2-8 | Male | 1/2 | No Adapter | 1 | 34.8 | (1.37) | 31.8 | (1.25) | 33.3 | (1.31) | - | - | - | - |
| 5400-S5-8 | Female | 1/2 | No Adapter | 2 | 41.4 | (1.63) | 33.3 | (1.31) | 25.4 | (1.00) | 30.2 | (1.19) | - | - |
| 5400-S2-12 | Male | 3/4 | No Adapter | 1 | 44.2 | (1.74) | 46.5 | (1.83) | 41.4 | (1.63) | - | - | - | - |
| 5400-S5-12 | Female | 3/4 | No Adapter | 2 | 54.6 | (2.15) | 45.7 | (1.80) | 35.1 | (1.38) | 41.4 | (1.63) | - | - |
| 5400-S2-16 | Male | 1 | No Adapter | 1 | 46.5 | (1.83) | 53.3 | (2.10) | 47.8 | (1.88) | - | - | - | - |
| 5400-S5-16 | Female | 1 | No Adapter | 2 | 60.2 | (2.37) | 56.9 | (2.24) | 44.5 | (1.75) | 50.8 | (2.00) | - | - |

Dimensions – SAE 37° (JIC)

| Part Number Buna-N | Coupling Type | Body Size | Port Size | Thread | Type | Fig. | Dimensions | | Hex ① | | Hex ② | | Hex ③ | | | |
|-----------------------|------------------|--------------|--------------|-----------|---------------|------|------------|--------|-------|--------|-------|--------|-------|--------|------|--------|
| | | | | | | | A | B | mm | (in) | mm | (in) | mm | (in) | mm | (in) |
| 5410-S17-4-4* | Male | 1/4 | 7/16 | 7/16-20 | SAE 37° (JIC) | 3 | 47.8 | (1.88) | 21.1 | (.83) | 19.1 | (.75) | - | - | 16.0 | (.63) |
| 5410-S14-4-4* | Female | 1/4 | 7/16 | 7/16-20 | SAE 37° (JIC) | 4 | 49.0 | (1.93) | 21.1 | (.83) | 16.0 | (.63) | 19.1 | (.75) | 15.7 | (.62) |
| 5410-4-4* | Complete | 1/4 | 7/16 | 7/16-20 | SAE 37° (JIC) | 5 | 89.9 | (3.54) | - | - | - | - | - | - | - | |
| 5410-S17-6-4* | Male | 1/4 | 9/16 | 9/16-18 | SAE 37° (JIC) | 3 | 48.0 | (1.89) | 21.1 | (.83) | 19.1 | (.75) | - | - | 16.0 | (.63) |
| 5410-S14-6-4* | Female | 1/4 | 9/16 | 9/16-18 | SAE 37° (JIC) | 4 | 49.3 | (1.94) | 21.1 | (.83) | 16.0 | (.63) | 19.1 | (.75) | 15.7 | (.62) |
| 5410-6-4* | Complete | 1/4 | 9/16 | 9/16-18 | SAE 37° (JIC) | 5 | 90.4 | (3.56) | - | - | - | - | - | - | - | |
| 5410-S17-6-8* | Male | 1/2 | 9/16 | 9/16-18 | SAE 37° (JIC) | 3 | 55.4 | (2.18) | 31.8 | (1.25) | 28.7 | (1.13) | - | - | 25.4 | (1.00) |
| 5410-S14-6-8* | Female | 1/2 | 9/16 | 9/16-18 | SAE 37° (JIC) | 4 | 61.7 | (2.43) | 33.3 | (1.31) | 25.4 | (1.00) | 30.2 | (1.19) | 25.4 | (1.00) |
| 5410-6-8* | Complete | 1/2 | 9/16 | 9/16-18 | SAE 37° (JIC) | 5 | 107.4 | (4.23) | - | - | - | - | - | - | - | |
| 5410-S17-8-8* | Male | 1/2 | 3/4 | 3/4-16 | SAE 37° (JIC) | 3 | 57.9 | (2.28) | 31.8 | (1.25) | 28.7 | (1.13) | - | - | 25.4 | (1.00) |
| 5410-S14-8-8* | Female | 1/2 | 3/4 | 3/4-16 | SAE 37° (JIC) | 4 | 64.3 | (2.53) | 33.3 | (1.31) | 25.4 | (1.00) | 30.2 | (1.19) | 25.4 | (1.00) |
| 5410-8-8* | Complete | 1/2 | 3/4 | 3/4-16 | SAE 37° (JIC) | 5 | 112.8 | (4.44) | - | - | - | - | - | - | - | |
| 5410-S17-10-12* | Male | 3/4 | 7/8 | 7/8-14 | SAE 37° (JIC) | 3 | 69.9 | (2.75) | 46.5 | (1.83) | 41.4 | (1.63) | - | - | 35.1 | (1.38) |
| 5410-S14-10-12* | Female | 3/4 | 7/8 | 7/8-14 | SAE 37° (JIC) | 4 | 80.3 | (3.16) | 45.7 | (1.80) | 35.1 | (1.38) | 41.1 | (1.62) | 35.1 | (1.38) |
| 5410-10-12* | Complete | 3/4 | 7/8 | 7/8-14 | SAE 37° (JIC) | 5 | 135.4 | (5.33) | - | - | - | - | - | - | - | |
| 5410-S17-12-12* | Male | 3/4 | 1 1/16 | 1 1/16-12 | SAE 37° (JIC) | 3 | 72.6 | (2.86) | 46.5 | (1.83) | 41.4 | (1.63) | - | - | 35.1 | (1.38) |
| 5410-S14-12-12* | Female | 3/4 | 1 1/16 | 1 1/16-12 | SAE 37° (JIC) | 4 | 83.1 | (3.27) | 45.7 | (1.80) | 35.1 | (1.38) | 41.1 | (1.62) | 35.1 | (1.38) |
| 5410-12-12* | Complete | 3/4 | 1 1/16 | 1 1/16-12 | SAE 37° (JIC) | 5 | 140.7 | (5.54) | - | - | - | - | - | - | - | |
| 5410-S17-16-16* | Male | 1 | 1 5/16 | 1 5/16-12 | SAE 37° (JIC) | 3 | 75.9 | (2.99) | 53.3 | (2.10) | 47.8 | (1.88) | - | - | 44.5 | (1.75) |
| 5410-S14-16-16* | Female | 1 | 1 5/16 | 1 5/16-12 | SAE 37° (JIC) | 4 | 89.7 | (3.53) | 56.9 | (2.24) | 44.5 | (1.75) | 50.8 | (2.00) | 44.5 | (1.75) |
| 5410-16-16* | Complete | 1 | 1 5/16 | 1 5/16-12 | SAE 37° (JIC) | 5 | 149.6 | (5.89) | - | - | - | - | - | - | - | |

*Couplings must be ordered by components as shown on page 65.

5400 Series

Low Air Inclusion Refrigerant

Dimensions – Braze Tubing Adapter

| Part Number Neoprene | Coupling Type | Body Size | Tube O.D. Size | Type | Fig. | Dimensions | | | | | | | | | |
|-------------------------|------------------|--------------|-------------------|----------------------|------|------------|--------|------|--------|-------|--------|-------|--------|-------|--------|
| | | | | | | A | | B | | Hex ① | | Hex ② | | Hex ③ | |
| | | | | | | mm | (in) | mm | (in) | mm | (in) | mm | (in) | mm | (in) |
| 5401-S17-4-4* | Male | 1/4 | 1/4 | Braze Tubing Adapter | 6 | 38.6 | (1.52) | 21.1 | (.83) | 19.1 | (.75) | - | - | 16.0 | (.63) |
| 5401-S14-4-4* | Female | 1/4 | 1/4 | Braze Tubing Adapter | 7 | 39.9 | (1.57) | 21.1 | (.83) | 16.0 | (.63) | 19.1 | (.75) | 16.0 | (.63) |
| 5401-S17-6-4* | Male | 1/4 | 3/8 | Braze Tubing Adapter | 6 | 38.6 | (1.52) | 21.1 | (.83) | 19.1 | (.75) | - | - | 16.0 | (.63) |
| 5401-S14-6-4* | Female | 1/4 | 3/8 | Braze Tubing Adapter | 7 | 39.9 | (1.57) | 21.1 | (.83) | 16.0 | (.63) | 19.1 | (.75) | 16.0 | (.63) |
| 5410-S17-6-8* | Male | 1/2 | 3/8 | Braze Tubing Adapter | 6 | 44.5 | (1.75) | 33.3 | (1.31) | 28.7 | (1.13) | - | - | 25.4 | (1.00) |
| 5401-S14-6-8* | Female | 1/2 | 3/8 | Braze Tubing Adapter | 7 | 50.8 | (2.00) | 33.3 | (1.31) | 25.4 | (1.00) | 30.2 | (1.19) | 25.4 | (1.00) |
| 5401-S17-8-8* | Male | 1/2 | 1/2 | Braze Tubing Adapter | 6 | 44.5 | (1.75) | 33.3 | (1.31) | 28.7 | (1.13) | - | - | 25.4 | (1.00) |
| 5401-S14-8-8* | Female | 1/2 | 1/2 | Braze Tubing Adapter | 7 | 50.8 | (2.00) | 33.3 | (1.31) | 25.4 | (1.00) | 30.2 | (1.19) | 25.4 | (1.00) |
| 5401-S17-10-12* | Male | 3/4 | 5/8 | Braze Tubing Adapter | 6 | 62.7 | (2.47) | 45.7 | (1.80) | 41.4 | (1.63) | - | - | 35.1 | (1.38) |
| 5401-S14-10-12* | Female | 3/4 | 5/8 | Braze Tubing Adapter | 7 | 73.2 | (2.88) | 45.7 | (1.80) | 35.1 | (1.38) | 41.4 | (1.63) | 35.1 | (1.38) |
| 5401-S17-12-12* | Male | 3/4 | 3/4 | Braze Tubing Adapter | 6 | 62.7 | (2.47) | 45.7 | (1.80) | 41.4 | (1.63) | - | - | 35.1 | (1.38) |
| 5401-S14-12-12* | Female | 3/4 | 3/4 | Braze Tubing Adapter | 7 | 73.2 | (2.88) | 45.7 | (1.80) | 35.1 | (1.38) | 41.4 | (1.63) | 35.1 | (1.38) |
| 5401-S17-16-16* | Male | 1 | 1 | Braze Tubing Adapter | 6 | 71.1 | (2.80) | 56.9 | (2.24) | 47.8 | (1.88) | - | - | 44.5 | (1.75) |
| 5401-S14-16-16* | Female | 1 | 1 | Braze Tubing Adapter | 7 | 84.8 | (3.34) | 56.9 | (2.24) | 44.5 | (1.75) | 50.8 | (2.00) | 44.5 | (1.75) |

*Couplings must be ordered by components as shown on page 65.

Dust Caps and Dust Plugs

| Dust Cap with Gasket | Dust Plug with Gasket | Body Size |
|----------------------|-----------------------|-----------|
| 5400-S6-4 | 5400-S8-4 | 1/4 |
| 5400-S6-8 | 5400-S8-8 | -1/2 |
| 5400-S6-12 | 5400-S8-12 | 3/4 |
| 5400-S6-16 | 5400-S8-16 | 1 |

Dust Cap Dust Plug



Adapter SAE 37° (JIC)

| O-ring | Brass | Steel | Body Size | Thread | Tube O.D. Size |
|----------|---------------|---------------|-----------|-----------|----------------|
| 22546-12 | 202220-4-4B | 202220-4-4S | 1/4 | 7/16-20 | 1/4 |
| 22546-12 | 202220-6-4B | 202220-6-4S | 1/4 | 9/16-18 | 3/8 |
| 22546-17 | 202220-6-8B | 202220-6-8S | 1/2 | 9/16-18 | 3/8 |
| 22546-17 | 202220-8-8B | 202220-8-8S | 1/2 | 3/4-16 | 1/2 |
| 22546-23 | 202220-10-12B | 202220-10-12S | 3/4 | 7/8-14 | 5/8 |
| 22546-23 | 202220-12-12B | 202220-12-12S | 3/4 | 1 1/16-12 | 3/4 |
| 22546-28 | 202220-16-16B | 202220-16-16S | 1 | 1 3/16-12 | 1 |

Adapter SAE 37° (JIC)

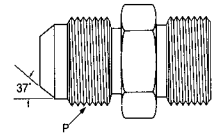

Adapter – Braze

| O-ring | Brass | Steel | Body Size | Thread | Tube O.D. Size |
|----------|---------------|-------|-----------|------------|----------------|
| 22546-12 | 202208-4-4B | - | 1/4 | 1/2-20 | 1/4 |
| 22546-17 | 202208-4-8B | - | 1/2 | 7/8-20 | 1/2 |
| 22546-12 | 202208-6-4B | - | 1/4 | 1/2-20 | 3/8 |
| 22546-17 | 202208-6-8B | - | 1/2 | 7/8-20 | 3/8 |
| 22546-17 | 202208-8-8B | - | 1/2 | 7/8-20 | 1/2 |
| 22546-17 | 202208-10-8B | - | 1/2 | 7/8-20 | 5/8 |
| 22546-23 | 202208-10-12B | - | 3/4 | 1 1/4-18 | 5/8 |
| 22546-23 | 202208-12-12B | - | 3/4 | 1 1/4-18 | 3/4 |
| 22546-23 | 202202-14-12B | - | 1 | 1 1/4-18 | 7/8 |
| 22546-28 | 202208-14-16B | - | 1 | 1 19/32-20 | 7/8 |
| 22546-28 | 202208-16-16B | - | 1 | 1 19/32-20 | 1 |
| 22546-28 | 202208-18-16B | - | 1 | 1 19/32-20 | 1 1/8 |
| 22546-28 | 202208-22-16B | - | 1 | 1 19/32-20 | 1 1/4 |

Adapter – Braze
(O-ring Required)

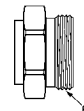

Hose Fitting SAE 100R5[†]

| O-ring | Fitting Assembly | Body Size | Hose Size | Thread | Dimensions D | |
|----------|------------------|-----------|-----------|------------|-----------------|--------|
| | | | | | mm | (in) |
| 22546-12 | 487-4-4S | 1/4 | -4 | 1/2-20 | 23.4 | (.92) |
| 22546-12 | 487-4-6S | 1/4 | -6 | 1/2-20 | 24.4 | (.96) |
| 22546-17 | 487-8-6S | 1/2 | -6 | 7/8-20 | 24.4 | (.96) |
| 22546-17 | 487-8-8S | 1/2 | -8 | 7/8-20 | 26.9 | (1.06) |
| 22546-23 | 487-12-10S | 3/4 | -10 | 1 1/4-18 | 27.2 | (1.07) |
| 22546-28 | 487-16-16S | 1 | -16 | 1 19/32-20 | 25.7 | (1.01) |

Hose Fitting SAE 100R5
(O-ring Required)

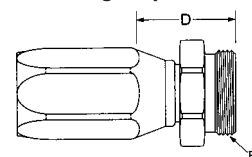

[†]Additional dash styles available.

5400 Series

Low Air Inclusion Refrigerant

For assemblies, order by components as shown by base number and dash (-) size below. Example, if a 5401-S14-10-12 is required, order as components, (1) 5400-S5-12, (1) 202208-10-12B Adapter and (1) 22546-23 O-ring.

| Assembly Part Number | 5400-S2 Female Half | Quantity | 5400-S5 Male Half | Quantity | 202208-Brass Braze-On Adapter | Quantity | 202220-Steel 37° SAE Adapter | Quantity | 22546 O-ring | Quantity |
|----------------------|---------------------|----------|-------------------|----------|-------------------------------|----------|------------------------------|----------|--------------|----------|
| 5401-S14-10-12 | | | -12 | 1 | -10 -12B | 1 | | | -23 | 1 |
| 5401-S14-10-8 | | | -8 | 1 | -10 -8B | | | | -17 | 1 |
| 5401-S14-12-12 | | | -12 | 1 | -12 -12B | 1 | | | -23 | 1 |
| 5401-S14-16-16 | | | -16 | 1 | -16 -16B | 1 | | | -28 | 1 |
| 5401-S14-4-4 | | | -4 | 1 | -4 -4B | 1 | | | -12 | 1 |
| 5401-S14-6-4 | | | -4 | 1 | -6 -4B | 1 | | | -12 | 1 |
| 5401-S14-6-8 | | | -8 | 1 | -6 -8B | 1 | | | -17 | 1 |
| 5401-S14-8-8 | | | -8 | 1 | -8 -8B | 1 | | | -17 | 1 |
| 5401-S17-10-12 | -12 | 1 | | | -10 -12B | 1 | | | -23 | 1 |
| 5401-S17-10-8 | -8 | 1 | | | -10 -8B | 1 | | | -17 | 1 |
| 5401-S17-12-12 | -12 | 1 | | | -12 -12 | 1 | | | -23 | 1 |
| 5401-S17-14-16 | -16 | 1 | | | -16 -16 | 1 | | | -28 | 1 |
| 5401-S17-4-4 | -4 | 1 | | | -4 -4B | 1 | | | -17 | 1 |
| 5401-S17-6-4 | -4 | 1 | | | -6 -4B | 1 | | | -12 | 1 |
| 5401-S17-6-8 | -8 | 1 | | | -6 -8B | 1 | | | -17 | 1 |
| 5401-S17-8-8 | -8 | 1 | | | -8 -8B | 1 | | | -17 | 1 |
| 5410-12-12 | -12 | 1 | -12 | 1 | | | -12 -12S | 2 | -23 | 2 |
| 5410-16-16 | -16 | 1 | -16 | 1 | | | -16 -16S | 2 | -28 | 2 |
| 5410-4-4 | -4 | 1 | -4 | 1 | | | -4 -4S | 2 | -12 | 2 |
| 5410-6-8 | -8 | 1 | -8 | 1 | | | -6 -8S | 2 | -17 | 2 |
| 5410-8-8 | -8 | 1 | -8 | 1 | | | -8 -8S | 2 | -17 | 2 |
| 5410-S14-10-12 | | | -12 | 1 | | | -10 -12S | 1 | -23 | 1 |
| 5410-S14-12-12 | | | -12 | 1 | | | -12 -12S | 1 | -23 | 1 |
| 5410-S14-16-16 | | | -16 | 1 | | | -16 -16S | 1 | -28 | 1 |
| 5410-S14-4-4 | | | -4 | 1 | | | -4 -4S | 1 | -12 | 1 |
| 5410-S14-6-4 | | | -4 | 1 | | | -6 -4S | 1 | -12 | 1 |
| 5410-S14-6-8 | | | -8 | 1 | | | -6 -8S | 1 | -17 | 1 |
| 5410-S14-8-8 | | | -8 | 1 | | | -8 -8S | 1 | -17 | 1 |
| 5410-S17-10-12 | -12 | 1 | | | | | -10 -12S | 1 | -23 | 1 |
| 5410-S17-12-12 | -12 | 1 | | | | | -12 -12S | 1 | -23 | 1 |
| 5410-S17-16-16 | -16 | 1 | | | | | -16 -16S | 1 | -28 | 1 |
| 5410-S17-4-4 | -4 | 1 | | | | | -4 -4S | 1 | -12 | 1 |
| 5410-S17-6-4 | -4 | 1 | | | | | -6 -4S | 1 | -12 | 1 |
| 5410-S17-6-8 | -8 | 1 | | | | | -6 -8S | 1 | -17 | 1 |
| 5410-S17-8-8 | -8 | 1 | | | | | -8 -8S | 1 | -17 | 1 |

5400 Series

Low Air Inclusion Refrigerant

Assembly Instructions/Component Part Numbers

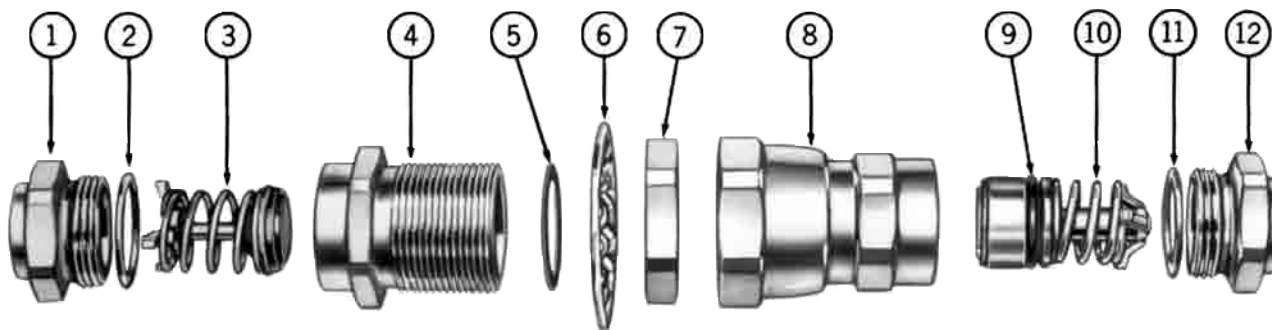

Typical Male Coupling Half (S2)

Assembly Instructions

Steps:

1. After tubing or hose has been connected to adapters ① and ⑫, install O-rings ② and ⑪* on adapters. Be sure O-rings are not twisted.
2. Oil O-rings ② and ⑪ liberally with system fluid to prevent them from scuffing and tearing when coupling body is threaded on adapter.
3. S2 Half—Lubricate poppet face with system fluid. Insert poppet valve assembly ③ into body ④. Tighten body ④ on adapter ①. After body and adapter make metal-to-metal contact, tighten by rotating body ④ 1/8" with respect to adapter ① or torque per table value.

S5 Half—Oil O-Ring ⑨* liberally with system fluid. Insert valve and sleeve assembly 10 into body ⑥. Tighten body ⑥ on adapter ⑫. After body and adapter make metal-to-metal contact, tighten by rotating body ⑥ 1/8" with respect to adapter ⑫ or torque per table value.

4. Coupling Connection—Lubricate gasket seal ⑤ on 5400-S2 half with system fluid. Thread union nut ⑧ on 5400-S2 half. Tighten union nut to torque values shown in table. Be sure S2 and S5 bodies do not rotate during connection.

Typical Female Coupling Half (S5)

Bulkhead Mounting—S2 Half

Install lock washer ⑥ on S2 half. Insert S2 half through bulkhead, and tighten jam nut ⑦ so that lock washer teeth are fully compressed.

NOTE: Lock washer 6 must be between hex of S2 half and bulkhead.

Maximum Bulkhead Thickness

| Body Size | Lock Washer Installed | Lock Washer Not Used |
|-----------|-----------------------|----------------------|
| 1/4 | .206 | .256 |
| 1/2 | .136 | .203 |
| 3/4 | .232 | .292 |
| 1 | .101 | .161 |

Torque Values

Recommended torque values in ft. lbs., are listed below.

| Dash Size | Adapter to Body | | |
|-----------|------------------------|-------------------------------|--------------------|
| | Braze Type or Aluminum | Non-braze Type Steel or Brass | S2 Half to S5 Half |
| -4 | 6-8 | 12-15 | 10-12 |
| -8 | 15-20 | 35-45 | 35-37 |
| -12 | 35-40 | 45-55 | 45-47 |
| -16 | 50-60 | 55-65 | 65-67 |

*IMPORTANT: Generous lubrication is required for all gaskets and O-rings.

Use refrigeration oil only when used in refrigerant system.

Component Part Numbers

| Item Number | Dash Size → O.D. Tube Size → | -4 1/4"-3/8" | -8 1/4"-5/8" | -12 5/8"-7/8" | -16 7/8"-13/8" | Line Ref. |
|----------------------------|---------------------------------|-----------------|-----------------|------------------|-------------------|-----------|
| Typical Male Half | | | | | | 1 |
| 1 | Tubing Adapter | 202208-* -4 | 202208-* -8 | 202208-* -12 | 202208-* -16 | 2 |
| 2 | O-ring | 22546-12 | 22546-17 | 22546-23 | 22546-28 | 3 |
| 3 | Poppet Valve Assembly | 5400-S20-4 | 5400-S20-8 | 5400-S20-12 | 5400-S20-16 | 4 |
| 4 | Body | 5400-17-4 | 5400-17-8 | 5400-17-12 | 5400-17-16 | 5 |
| 5 | Gasket Seal | 22008-4 | 22008-8 | 22008-12 | 22008-16 | 6 |
| 6 | Lock Washer | 5400-54-4S | 5400-54-8S | 5400-54-12S | 5400-54-16S | 7 |
| 7 | Jam Nut | 5400-53-4S | 5400-53-8S | 5400-53-12S | 5400-53-16S | 8 |
| Typical Female Half | | | | | | 9 |
| 8 | Union Nut and Body Assembly | 5400-S16-4 | 5400-S16-8 | 5400-S16-12 | 5400-S16-16 | 10 |
| 9 | O-ring | 22546-10 | 22546-112 | 22546-116 | 22546-214 | 11 |
| 10 | Valve and Sleeve Assembly | 5400-S19-4 | 5400-S19-8 | 5400-S19-12 | 5400-S19-16 | 12 |
| 11 | O-ring | 22546-12 | 22546-17 | 22546-23 | 22546-28 | 13 |
| 12 | Tubing Adapter | 202208-* -4 | 202208-* -8 | 202208-* -12 | 202208-* -16 | 14 |

*Specify O.D. Tubing size of adapter required in 16th of an inch. Example: -4 coupling with 3/8" O.D. tubing is 6/16 or -6. Part number is then 202208-6-4.

FD40 Series

MIL-C-4109 Interchange



The FD40 Series offers a one-hand push-to-connect latch ideal for compressed air service, utilizing a ball latching mechanism. The female half features self-sealing poppet valves, preventing air loss while disconnected. The male half uses a straight through non-valved design.

Product Features

- Automatic sleeve for one-hand push-to-connect operation with pin latching mechanism
- Protective sleeve lock prevents accidental disconnection
- Meet dimensional requirements of MIL-C-4109 for industrial interchangeability
- Swivels 360°, eliminating hose kinking
- Standard seal material – Buna-N
- Standard body material (Male) – High resistance carbon steel with zinc trivalent chromate plating
- Standard body material (Female) – Brass

Physical Characteristics

| Body Size | Max. Operating Pressure | | Min. Burst Pressure Female Half Only | | Connected | | Vacuum Connected Only |
|-----------|-------------------------|-------|--------------------------------------|---------|-----------|---------|-----------------------|
| | bar | (psi) | bar | (psi) | bar | (psi) | (in./Hg) |
| 1/4 | 21 | (300) | 210 | (3,000) | 560 | (8,000) | 28 |
| 3/8 | 21 | (300) | 210 | (3,000) | 560 | (8,000) | 28 |
| 1/2 | 21 | (300) | 210 | (3,000) | 560 | (8,000) | 28 |



Applications

- Compressed air
- Pneumatic tools
- MIL-C-4109 Interchange



Flow Data

Pressure Drop Versus Flow Graph

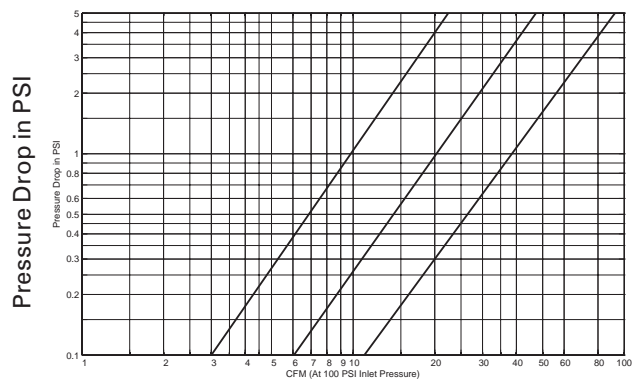

Cubic Feet Per Minute Flow
Test Fluid: Air at 100 PSI Inlet Pressure

FD40 Series

NFPA standard T3.20.15
HTMA Interchange

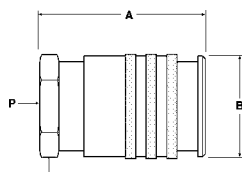

Figure 1

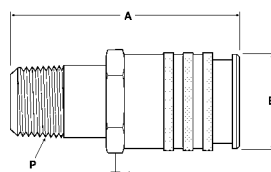

Figure 2

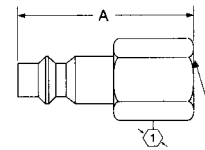

Figure 3

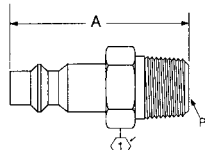

Figure 4

Dimensions — Female Pipe

| Part Number | Coupling Type | Body Size | Port Size | Thread | Type | Fig. | Dimensions A | | B | | Hex ① | |
|-----------------|---------------|-----------|-----------|--------|------------|------|--------------|--------|------|--------|-------|--------|
| | | | | | | | mm | (in) | mm | (in) | mm | (in) |
| FD40-1013-02-04 | Male | 1/4 | 1/8 | 1/8-27 | Female NPT | 3 | 30.7 | (1.21) | - | - | 14.2 | (.56) |
| FD40-1054-04-04 | Female | 1/4 | 1/4 | 1/4-18 | Female NPT | 1 | 58.6 | (2.11) | 30.2 | (1.19) | 17.5 | (.69) |
| FD40-1013-04-04 | Male | 1/4 | 1/4 | 1/4-18 | Female NPT | 3 | 41.1 | (1.62) | - | - | 15.7 | (.62) |
| FD40-1054-06-04 | Female | 1/4 | 3/8 | 3/8-18 | Female NPT | 1 | 58.6 | (2.11) | 30.2 | (1.19) | 19.1 | (.75) |
| FD40-1013-06-04 | Male | 1/4 | 3/8 | 3/8-18 | Female NPT | 3 | 45.7 | (1.80) | - | - | 22.4 | (.88) |
| FD40-1054-04-06 | Female | 3/8 | 1/4 | 1/4-18 | Female NPT | 1 | 53.3 | (2.10) | 35.1 | (1.38) | 22.4 | (.88) |
| FD40-1054-06-06 | Female | 3/8 | 3/8 | 3/8-18 | Female NPT | 1 | 59.7 | (2.35) | 35.1 | (1.38) | 22.4 | (.88) |
| FD40-1013-06-06 | Male | 3/8 | 3/8 | 3/8-18 | Female NPT | 3 | 48.3 | (1.90) | - | - | 22.4 | (.88) |
| FD40-1054-08-08 | Female | 1/2 | 1/2 | 1/2-14 | Female NPT | 1 | 78.0 | (3.60) | 43.4 | (1.71) | 25.4 | (1.00) |
| FD40-1013-08-08 | Male | 1/2 | 1/2 | 1/2-14 | Female NPT | 3 | 61.0 | (2.40) | - | - | 28.4 | (1.12) |

Dimensions — Male Pipe

| Part Number | Coupling Type | Body Size | Port Size | Thread | Type | Fig. | Dimensions A | | B | | Hex ① | |
|-----------------|---------------|-----------|-----------|--------|----------|------|--------------|--------|------|--------|-------|--------|
| | | | | | | | mm | (in) | mm | (in) | mm | (in) |
| FD40-1055-04-04 | Female | 1/4 | 1/4 | 1/4-18 | Male NPT | 2 | 55.6 | (2.19) | 30.2 | (1.19) | 17.5 | (0.69) |
| FD40-1014-04-04 | Male | 1/4 | 1/4 | 1/4-18 | Male NPT | 4 | 42.9 | (1.69) | - | - | 14.2 | (0.56) |
| FD40-1055-06-04 | Female | 1/4 | 3/8 | 3/8-18 | Male NPT | 2 | 54.6 | (2.15) | 30.2 | (1.19) | 17.5 | (0.69) |
| FD40-1014-06-04 | Male | 1/4 | 3/8 | 3/8-18 | Male NPT | 4 | 44.5 | (1.75) | - | - | 17.5 | (0.69) |
| FD40-1014-02-04 | Male | 1/4 | 1/8 | 1/8-27 | Male NPT | 4 | 38.1 | (1.50) | - | - | 12.7 | (0.50) |
| FD40-1055-06-06 | Female | 3/8 | 3/8 | 3/8-18 | Male NPT | 2 | 59.7 | (2.35) | 35.1 | (1.38) | 22.4 | (0.88) |
| FD40-1014-06-06 | Male | 3/8 | 3/8 | 3/8-18 | Male NPT | 4 | 47.8 | (1.88) | - | - | 17.5 | (0.69) |
| FD40-1014-04-06 | Male | 3/8 | 1/4 | 1/4-18 | Male NPT | 4 | 47.8 | (1.88) | - | - | 15.7 | (0.62) |
| FD40-1014-08-06 | Male | 3/8 | 1/2 | 1/2-14 | Male NPT | 4 | 54.1 | (2.13) | - | - | 22.4 | (0.88) |
| FD40-1055-08-08 | Female | 1/2 | 1/2 | 1/2-14 | Male NPT | 2 | 75.5 | (2.97) | 38.1 | (1.50) | 25.4 | (1.00) |
| FD40-1014-08-08 | Male | 1/2 | 1/2 | 1/2-14 | Male NPT | 4 | 62.0 | (2.44) | - | - | 22.4 | (0.88) |
| FD40-1014-06-08 | Male | 1/2 | 3/8 | 3/8-18 | Male NPT | 4 | 55.4 | (2.18) | - | - | 17.5 | (0.69) |

FD41 Series

ARO 210 Interchange



The FD41 Series ARO 210 interchange is designed for compressed air service with a self-sealing female half and straight through male half. The FD40 assures high flow with low pressure drop for peak tool performance.

Product Features

- Designed to interchange with ARO 210 Series
- Automatic sleeve for one hand push-to-connect operation.
- Swivels 360°, eliminating hose kinking
- Standard seal material – Buna-N
- Standard body material – High resistance carbon steel with zinc trivalent chromate plating

Applications

- Compressed air
- Pneumatic tools
- ARO 210 Interchange



Physical Characteristics

| Body Size | Max. Operating Pressure | | Min. Burst Pressure Female Half Only | | Connected | | Vacuum Connected Only |
|-----------|-------------------------|-------|--------------------------------------|---------|-----------|---------|-----------------------|
| | bar | (psi) | bar | (psi) | bar | (psi) | (in./Hg) |
| 1/4 | 21 | (300) | 210 | (3,000) | 560 | (8,000) | 28 |

Dimensions – Female Pipe

| Part Number | Coupling Type | Body Size | Port Size | Thread | Type | Fig. | Dimensions A | | B | | Hex | |
|-----------------|---------------|-----------|-----------|--------|------------|------|--------------|--------|------|--------|------|-------|
| | | | | | | | mm | (in) | mm | (in) | mm | (in) |
| FD41-1000-02-04 | Female | 1/4 | 1/8 | 1/8-27 | Female NPT | 1 | 54.6 | (2.15) | 28.4 | (1.12) | 20.6 | (.81) |
| FD41-1000-04-04 | Female | 1/4 | 1/4 | 1/4-18 | Female NPT | 1 | 41.1 | (1.62) | 28.4 | (1.12) | 20.6 | (.81) |
| FD41-1013-04-04 | Male | 1/4 | 1/4 | 1/4-18 | Female NPT | 2 | 37.6 | (1.48) | - | - | 15.7 | (.62) |

Dimensions – Male Pipe

| Part Number | Coupling Type | Body Size | Port Size | Thread | Type | Fig. | Dimensions A | | B | | Hex | |
|-----------------|---------------|-----------|-----------|--------|----------|------|--------------|--------|----|------|------|-------|
| | | | | | | | mm | (in) | mm | (in) | mm | (in) |
| FD41-1014-04-04 | Male | 1/4 | 1/4 | 1/4-18 | Male NPT | 3 | 40.9 | (1.61) | - | - | 14.2 | (.56) |

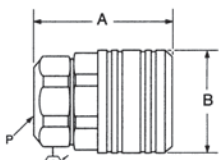

Figure 1

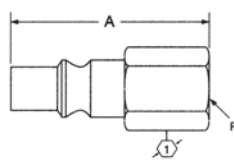

Figure 2

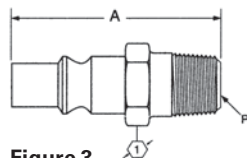
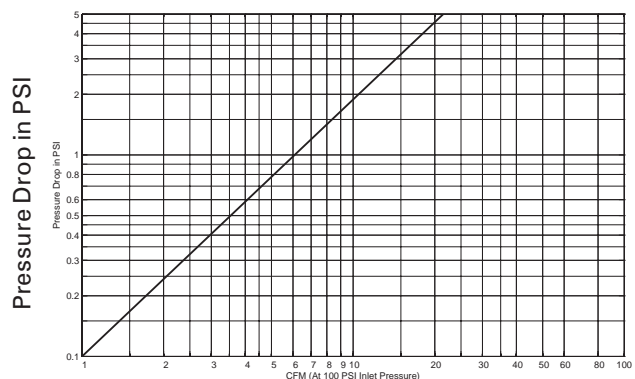

Figure 3

Flow Data

Pressure Drop Versus Flow Graph



Cubic Feet Per Minute Flow

Test Fluid: Air at 100 PSI Inlet Pressure

FD43 Series

MIL-C-4109 Interchange



The FD43 Series is a manual retract-type ball latch industrial interchange coupling designed specifically for compressed air service. The FD43 Series uses FD40 Series male tips.

Product Features

- Meets dimensional requirements of MIL-C-4109 specifications for industrial interchangeability
- Protective collar to prevent accidental snagging and disconnection
- Manual retract latch design allows quick and easy connection of hose lines
- Swivels 360°, eliminating hose kinking
- Standard seal material – Neoprene
- Standard body material – High resistance carbon steel with zinc trivalent chromate plating

Physical Characteristics

| Body Size | Max. Operating Pressure | | Min. Burst Pressure Female Half Only | | Connected | | Vacuum Connected Only |
|-----------|-------------------------|-------|--------------------------------------|---------|-----------|---------|-----------------------|
| | bar | (psi) | bar | (psi) | bar | (psi) | (in./Hg) |
| 1/4 | 21 | (300) | 210 | (3,000) | 560 | (8,000) | Not Rated |
| 3/8 | 21 | (300) | 210 | (3,000) | 560 | (8,000) | Not Rated |
| 1/2 | 21 | (300) | 210 | (3,000) | 560 | (8,000) | Not Rated |

Applications

- Compressed air
- Pneumatic tools
- MIL-C-4109 Interchange



Flow Data

Pressure Drop Versus Flow Graph

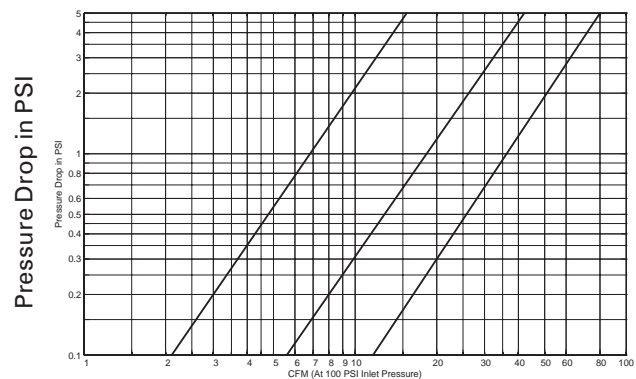

Cubic Feet Per Minute Flow
Test Fluid: Air at 100 PSI Inlet Pressure

FD43 Series

MIL-C-4109 Interchange

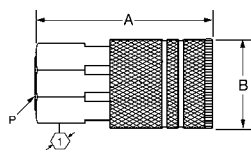

Figure 1

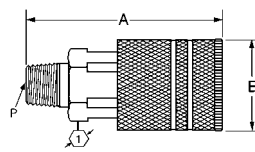

Figure 2

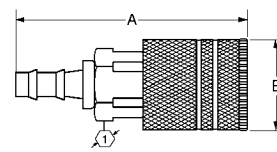

Figure 3

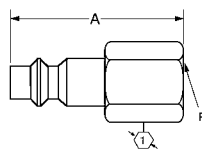

Figure 4

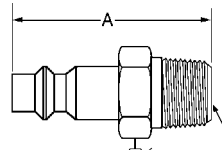

Figure 5

Dimensions — Female Pipe

| Part Number | Coupling Type | Body Size | Port Size | Thread | Type | Fig. | Dimensions A | | Dimensions B | | Hex ① | |
|-----------------|---------------|-----------|-----------|--------|------------|------|--------------|--------|--------------|--------|-------|--------|
| | | | | | | | mm | (in) | mm | (in) | mm | (in) |
| FD40-1013-02-04 | Male | 1/4 | 1/8 | 1/8-27 | Female NPT | 4 | 30.7 | (1.21) | - | - | 14.2 | (.56) |
| FD43-1001-04-04 | Female | 1/4 | 1/4 | 1/4-18 | Female NPT | 1 | 53.1 | (2.09) | 22.4 | (.88) | 19.0 | (.75) |
| FD40-1013-04-04 | Male | 1/4 | 1/4 | 1/4-18 | Female NPT | 4 | 41.1 | (1.62) | - | - | 15.7 | (.62) |
| FD43-1001-06-04 | Female | 1/4 | 3/8 | 3/8-18 | Female NPT | 1 | 54.9 | (2.16) | 22.4 | (.88) | 20.6 | (.81) |
| FD40-1013-06-04 | Male | 1/4 | 3/8 | 3/8-18 | Female NPT | 4 | 45.7 | (1.80) | - | - | 22.4 | (.88) |
| FD43-1001-06-06 | Female | 3/8 | 3/8 | 3/8-18 | Female NPT | 1 | 60.5 | (2.38) | 26.9 | (1.06) | 22.4 | (.88) |
| FD40-1013-06-06 | Male | 3/8 | 3/8 | 3/8-18 | Female NPT | 4 | 48.3 | (1.90) | - | - | 22.4 | (.88) |
| FD43-1001-04-06 | Female | 3/8 | 1/4 | 1/4-18 | Female NPT | 1 | 60.5 | (2.38) | 26.9 | (1.06) | 22.4 | (.88) |
| FD43-1001-08-08 | Female | 1/2 | 1/2 | 1/2-14 | Female NPT | 1 | 77.7 | (3.06) | 30.2 | (1.19) | 25.4 | (1.00) |
| FD40-1013-08-08 | Male | 1/2 | 1/2 | 1/2-14 | Female NPT | 4 | 61.0 | (2.40) | - | - | 28.4 | (1.12) |

Dimensions — Male Pipe

| Part Number | Coupling Type | Body Size | Port Size | Thread | Type | Fig. | Dimensions A | | Dimensions B | | Hex ① | |
|-----------------|---------------|-----------|-----------|--------|-----------|------|--------------|--------|--------------|--------|-------|--------|
| | | | | | | | mm | (in) | mm | (in) | mm | (in) |
| FD40-1014-02-04 | Male | 1/4 | 1/8 | 1/8-27 | Male Pipe | 5 | 38.1 | (1.50) | - | - | 12.7 | (0.50) |
| FD43-1011-04-04 | Female | 1/4 | 1/4 | 1/4-18 | Male Pipe | 2 | 57.9 | (2.28) | 22.4 | (0.88) | 19.0 | (0.75) |
| FD40-1014-04-04 | Male | 1/4 | 1/4 | 1/4-18 | Male Pipe | 5 | 42.9 | (1.69) | - | - | 14.2 | (0.56) |
| FD43-1011-06-04 | Female | 1/4 | 3/8 | 3/8-18 | Male Pipe | 2 | 59.4 | (2.34) | 22.4 | (0.88) | 19.0 | (0.75) |
| FD40-1014-06-04 | Male | 1/4 | 3/8 | 3/8-18 | Male Pipe | 5 | 44.4 | (1.75) | - | - | 17.5 | (0.69) |
| FD40-1014-04-06 | Male | 3/8 | 1/4 | 1/4-18 | Male Pipe | 5 | 47.8 | (1.88) | - | - | 15.7 | (0.62) |
| FD43-1011-06-06 | Female | 3/8 | 3/8 | 3/8-18 | Male Pipe | 2 | 62.0 | (2.44) | 26.9 | (1.06) | 22.4 | (0.88) |
| FD40-1014-06-06 | Male | 3/8 | 3/8 | 3/8-18 | Male Pipe | 5 | 47.8 | (1.88) | - | - | 17.5 | (0.69) |
| FD40-1014-08-06 | Male | 3/8 | 1/2 | 1/2-14 | Male Pipe | 5 | 54.1 | (2.13) | - | - | 22.4 | (0.88) |
| FD43-1011-08-08 | Female | 1/2 | 1/2 | 1/2-14 | Male Pipe | 2 | 78.5 | (3.09) | 30.2 | (1.19) | 25.4 | (1.00) |
| FD40-1014-08-08 | Male | 1/2 | 1/2 | 1/2-14 | Male Pipe | 5 | 62.0 | (2.44) | - | - | 22.4 | (0.88) |
| FD40-1014-06-08 | Male | 1/2 | 3/8 | 3/8-18 | Male Pipe | 5 | 55.4 | (2.18) | - | - | 17.5 | (0.69) |

Dimensions — SOCKETLESS™ Hose Barb

| Part Number Neoprene | Coupling Type | Body Size | Hose I.D. | Fig. | Dimensions A | | Dimensions B | | Hex ① | |
|----------------------|---------------|-----------|-----------|------|--------------|--------|--------------|-------|-------|-------|
| | | | | | mm | (in) | mm | (in) | mm | (in) |
| FD43-1031-04-04 | Female | 1/4 | 1/4 | 3 | 70.6 | (2.78) | 22.4 | (.88) | 19.0 | (.75) |

When using Eaton coupling products with other manufacturers' adapters, hoses, couplings, etc., do not exceed the lowest pressure rating of any of the components being used or rupture may result.

| EATON | HANSEN | FASTER | STUCCHI | PARKER | PERFECTING | SAFEWAY | SNAP-TITE | TOMCO |
|-----------------|-----------------------|---------------|-----------|---------|------------|-----------|-----------|---------|
| 150-22-12 | FL96-075 | - | - | 6107-08 | W6-BMF | S512-6 | 78F-12 | 51F-12 |
| 150-22-16 | FL96-100 | - | - | 6107-16 | W8-BMF | S512-8 | 78F-16 | 51F-16 |
| 150-22-20 | FL96-125 | - | - | 6107-20 | W10-BMF | S512-10 | 78F-20 | 51F-20 |
| 150-22-5 | - | - | - | - | - | - | - | - |
| 150-22-8 | - | - | - | - | - | - | - | - |
| FD31-1001-04-04 | WA-56517-00 | PVVM1/14NPT-F | 800201008 | 3050-2 | 2TM2 | - | 76C4-4M | JC2-15 |
| FD31-1001-06-06 | WA-56527-00 | PVVM1/38NPT-F | 800201004 | 3050-3 | 3TM3 | - | 76C6-6M | JC3-20 |
| FD31-1002-04-04 | WA-56514-00 | PVVM14NPT-M | 800201009 | 3010-2 | T2F2 | - | 76N4-4F | JP2-16 |
| FD31-1002-06-06 | WA56524-00 | PVVM38NPT-M | 800201005 | 3010-3 | T3F3 | - | 76N6-6F | JP3-21 |
| FD31-1004-04 | WA-56114-00 | TFP-14 | 815605005 | 3005-2 | T2DC | - | 76MDC-4 | JC2-DCP |
| FD31-1004-06 | WA-56124-00 | TFP-38 | 815605003 | 3005-3 | T3DC | - | 76MDC-6 | JC3-DCP |
| FD31-1005-04 | WA-56117-00 | TMP-14 | 815605004 | 3009-2 | 2TDP | - | 76MDC-4 | JC2-DCP |
| FD31-1005-06 | WA-56127-00 | TMP-38 | 815605002 | 3009-3 | 3TDP | - | 76MDC-6 | JC3-DCP |
| FD35-1000-06-06 | - | - | - | - | - | - | - | - |
| FD35-1001-06-06 | UP10S-37F | - | - | TC-371 | - | - | - | - |
| FD35-1002-06-06 | UP10P-37F | - | - | TC-372 | - | - | - | - |
| FD35-1006-06-06 | - | - | - | - | - | - | - | - |
| FD35-1007-06-06 | - | - | - | - | - | - | - | - |
| FD35-1008-06-06 | - | - | - | - | - | - | - | - |
| FD35-1042-06 | P-PDC-2-HK/P-SDC-2-HK | - | - | TR-37 | - | - | - | - |
| FD35-1043-06-06 | - | - | - | - | - | - | - | - |
| FD35-1044-06-06 | - | - | - | - | - | - | - | - |
| FD40-1013-02-04 | 13 | - | - | H1C | D2F1 | - | - | 1803 |
| FD40-1013-04-04 | 11 | - | - | H3C | D2F2 | S821-2F | - | 1805 |
| FD40-1013-06-04 | 15 | - | - | H3C-E | D2F3 | - | - | 1807 |
| FD40-1013-06-06 | 43 | - | - | H3E | D3F3 | S821-3F | - | T43 |
| FD40-1013-08-08 | 55 | - | - | H3F | D4F4 | - | - | T55 |
| FD40-1014-02-04 | 12 | - | - | H0C | D2M1 | - | - | 1802 |
| FD40-1014-04-04 | 10 | - | - | H2C | D2M2 | S821-2M | - | 1804 |
| FD40-1014-04-06 | 40 | - | - | H0E | D3M2 | S821-3-2M | - | T40 |
| FD40-1014-06-04 | 14 | - | - | H2C-E | D2M3 | - | - | 1806 |
| FD40-1014-06-06 | 42 | - | - | H2E | D3M3 | S821-3M | - | T42 |
| FD40-1014-06-08 | 52 | - | - | H0F | D4M3 | - | - | T52 |
| FD40-1014-08-06 | 44 | - | - | H2E-F | D3M4 | - | - | T44 |
| FD40-1014-08-08 | 54 | - | - | H2F | D4M4 | - | - | T54 |
| FD40-1054-04-04 | 3000 | - | - | B33 | 2DF2-B | S825-2 | - | 184 |
| FD40-1054-04-06 | 4000 | - | - | B35C | 3DF2-B | - | - | T4000 |
| FD40-1054-06-04 | 3200 | - | - | B33E | 2DF3-B | - | - | 185 |

| EATON | HANSEN | FASTER | STUCCHI | PARKER | PERFECTING | SAFEWAY | SNAP-TITE | TOMCO |
|-----------------|------------|---------------|-----------|------------|------------|-------------|------------|------------|
| FD40-1054-06-06 | 4200 | - | - | B35 | 3DF3-B | S825-3 | - | T4200 |
| FD40-1054-08-08 | 5200 | - | - | B37 | 4DF4-B | - | - | T5200 |
| FD40-1055-04-04 | 3100 | - | - | B32 | 2DM2-B | S825-2M | - | 181 |
| FD40-1055-06-04 | 3300 | - | - | B32E | 2DM3-B | - | - | 182 |
| FD40-1055-06-06 | 4300 | - | - | B34 | 3DM3-B | S825-3M | - | T4300 |
| FD40-1055-08-08 | 5300 | - | - | B36 | 4DM4-B | - | - | T5300 |
| FD41-1000-02-04 | - | - | - | - | - | - | - | 103 |
| FD41-1000-04-04 | 210 | - | - | HA-251-4FP | 2MF2 | S805-2 | - | 100 |
| FD41-1000-06-04 | - | - | - | - | - | - | - | 106 |
| FD41-1013-04-04 | 2609 | - | - | A3C | M2F2 | S801-2F | - | 300 |
| FD41-1014-04-04 | 2608 | - | - | A2C | M2M2 | S801-2M | - | 200 |
| FD43-1001-04-04 | 1000 | - | - | B23 | 2FF2-B | S825-2 | - | M184 |
| FD43-1001-06-04 | 1200 | - | - | B23E | 2FF3-B | - | - | M185 |
| FD43-1001-06-06 | 420 | - | - | 25 | 3FF3 | S825-3 | - | T420 |
| FD43-1001-08-08 | 520 | - | - | 17 | 4FF4 | - | - | T520 |
| FD43-1011-04-04 | 1100 | - | - | B22 | 2FM2-B | S825-2M | - | M181 |
| FD43-1011-06-06 | 430 | - | - | 24 | 3FM3 | S825-3M | - | T430 |
| FD43-1011-08-08 | 530 | - | - | 16 | 4FM4 | - | - | T530 |
| FD43-1031-04-04 | 1600P | - | - | B20-3BP | 2FB2-B | - | - | - |
| FD45-1002-02-02 | 1-K11 | HNV-18-NPT-M | 800601001 | H1-63 | H1F1 | S101-1 | 72N2-2F | TK1-11 |
| FD45-1002-04-04 | 2-K16 | HNV-14-NPT-M | 800601003 | H2-63 | H2F2 | S101-2 | 72N4-4F | TK2-16 |
| FD45-1002-06-06 | 3-K21 | HNV-38-NPT-M | 800601005 | H3-63 | H3F3 | S101-3 | 72N6-6F | TK3-21 |
| FD45-1002-08-10 | 4-KP26 | HNV-12-NPT-M | 800601007 | H4-63 | H4F4 | S101-4 | 72N8-8F | TK4-26 |
| FD45-1002-12-12 | 6-KP31 | HNV-34-NPT-M | 800601009 | H6-63 | H6F6 | S101-6 | 72N12-12F | TK6-31 |
| FD45-1002-16-16 | 8-KP36 | HNV-1-NPT-M | 800601011 | H8-63 | H8F8 | S101-8 | 72N16-16F | TK8-36 |
| FD45-1003-02-02 | 1-H11 | HNV-18-NPT-F | 800601000 | H1-62 | 1HF1 | S105-1 | 72C2-2F | TH1-11 |
| FD45-1003-04-04 | 2-H16 | HNV-14-NPT-F | 800601002 | H2-62 | 2HF2 | S105-2 | 72C4-4F | TH2-16 |
| FD45-1003-06-06 | 3-H21 | HNV-38-NPT-F | 800601004 | H3-62 | 3HF3 | S105-3 | 72C6-6F | TH3-21 |
| FD45-1003-08-10 | 4-HP26 | HNV-12-NPT-F | 800601006 | H4-62 | 4HF4 | S105-4 | 72C8-8F | TH4-26 |
| FD45-1003-12-12 | 6-HP31 | HNV-34-NPT-F | 800601008 | H6-62 | 6HF6 | S105-6 | 72C12-12F | TH6-31 |
| FD45-1003-16-16 | 8-HP36 | HNV-1-NPT-F | 800601010 | H8-62 | 8HF8 | S105-8 | 72C16-16F | TH8-36 |
| FD45-1004-04-04 | LL2-K16 | HNV-14-NPT-M2 | 804601103 | SH2-63 | H2F2-S | SS101-2 | S72N4-4F | TK2-16-303 |
| FD45-1004-06-06 | LL3-K21 | HNV-38-NPT-M2 | 804601105 | SH3-63 | H3F3-S | SS101-3 | S72N6-6F | TK3-21-303 |
| FD45-1004-08-10 | LL4-KP26 | HNV-12-NPT-M2 | 804601107 | SH4-63 | H4F4-S | SS101-4 | S72N8-8F | TK4-26-303 |
| FD45-1004-12-12 | LL6-KP31 | HNV-34-NPT-M2 | 804601109 | SH6-63 | H6F6-S | SS101-6 | S72N12-12F | TK6-31-303 |
| FD45-1004-16-16 | LL8-KP36 | HNV-1-NPT-M2 | 804601111 | SH8-63 | H8F8-S | SS101-8 | S72N16-16F | TK8-36-303 |
| FD45-1004-16-16 | 19FPF131UN | FFB4-1SAE-M | 800804013 | - | HT60F8 | FFE491-6-16 | 74N12-16EF | - |
| FD45-1005-04-04 | LL2-H16 | HNV-14-NPT-F2 | 804601102 | SH2-62 | 2HF2-S | SS105-2 | S72C4-4F | TH2-16-303 |
| FD45-1005-06-06 | LL3-H21 | HNV-38-NPT-F2 | 804601104 | SH3-62 | 3HF3-S | SS105-3 | S72C6-6F | TH3-21-303 |
| FD45-1005-08-10 | LL4-HP26 | HNV-12-NPT-F2 | 804601106 | SH4-62 | 4HF4-S | SS105-4 | S72C8-8F | TH4-26-303 |

| EATON | HANSEN | FASTER | STUCCHI | PARKER | PERFECTING | SAFEWAY | SNAP-TITE | TOMCO |
|-----------------|------------|-----------------|-----------|-------------|------------|-----------|------------|------------|
| FD45-1005-12-12 | LL6-HP31 | HNV-34-NPT-F2 | 804601108 | SH6-62 | 6HF6-S | SS105-6 | S72C12-12F | TH6-31-303 |
| FD45-1005-16-16 | LL8-HP36 | HNV-1-NPT-F2 | 804601110 | SH8-62 | 8HF8-S | SS105-8 | S72C16-16F | TH8-36-303 |
| FD45-1040-02 | P-PDC-1-HK | TFH-18 | - | H1-66M | H1-DC | S19-1 | 72PDC-2 | TK1D |
| FD45-1040-04 | P-PDC-2-HK | TFH-14 | 815000033 | H2-66M | H2-DC | S19-2 | 72PDC-4 | TK2D |
| FD45-1040-06 | P-PDC-3-HK | TFH-38 | 815000035 | H3-66M | H3-DC | S19-3 | 72PDC-6 | TK3D |
| FD45-1040-10 | P-PDC-4-HK | TFH-12 | 815000037 | H4-66M | H4-DC | S19-4 | 72PDC-8 | TK4D |
| FD45-1040-12 | P-PDC-6-HK | TFH-34 | 815000039 | H6-66M | H6-DC | S19-6 | 72PDC-12 | TK6D |
| FD45-1040-16 | P-PDC-8-HK | TFH-1 | 815000041 | H8-66M | H8-DC | S19-8 | 72PDC-16 | TK8D |
| FD45-1041-02 | P-SDC-1-HK | TMH-18 | - | H1-65M | 1H-DP | S14-1 | 72PDP-2 | TH1D |
| FD45-1041-04 | P-SDC-2-HK | TMH-14 | 815000032 | H2-65M | 2H-DP | S14-2 | 72PDP-4 | TH2D |
| FD45-1041-06 | P-SDC-3-HK | TMH-38 | 815000034 | H3-65M | 3H-DP | S14-3 | 72PDP-6 | TH3D |
| FD45-1041-10 | P-SDC-4-HK | TMH-12 | 815000036 | H4-65M | 4H-DP | S14-4 | 72PDP-8 | TH4D |
| FD45-1041-12 | P-SDC-6-HK | TMH-34 | 815000038 | H6-65M | 6H-DP | S14-6 | 72PDP-12 | TH6D |
| FD45-1041-16 | P-SDC-8-HK | TMH-1 | 815000040 | H8-65M | 8H-DP | S14-8 | 72PDP-16 | TH8D |
| FD45-1086-02-02 | B1-K11 | HNV-18-NPT-M5 | 804501101 | BH1-61 | H1F1-B | BS101-1 | B72N2-2F | TK1-11-002 |
| FD45-1086-04-04 | B2-K16 | HNV-14-NPT-M5 | 804501103 | BH2-61 | H2F2-B | BS101-2 | B72N4-4F | TK2-16-002 |
| FD45-1086-06-06 | B3-K21 | HNV-38-NPT-M5 | 804501105 | BH3-61 | H3F3-B | BS101-3 | B72N6-6F | TK3-21-002 |
| FD45-1086-08-10 | B4-KP26 | HNV-12-NPT-M5 | 804501107 | BH4-61 | H4F4-B | BS101-4 | B72N8-8F | TK4-26-002 |
| FD45-1086-12-12 | B6-KP31 | HNV-34-NPT-M5 | 804501109 | BH6-61 | H6F6-B | BS101-6 | B72N12-12F | TK6-31-002 |
| FD45-1086-16-16 | B8-KP36 | HNV-1-NPT-M5 | 804501111 | BH8-61 | H8F8-B | BS101-8 | B72N16-16F | TK8-36-002 |
| FD45-1086-20-20 | B10-K41 | - | - | - | H10F10-B | - | - | - |
| FD45-1101-02-02 | B1-H11 | HNV-18-NPT-F5 | 804501100 | BH1-60 | 1HF1-B | BS105-1 | B72C2-2F | TH1-11-002 |
| FD45-1101-04-04 | B2-H16 | HNV-14-NPT-F5 | 804501102 | BH2-60 | 2HF2-B | BS105-2 | B72C4-4F | TH2-16-002 |
| FD45-1101-06-06 | B3-H21 | HNV-38-NPT-F5 | 804501104 | BH3-60 | 3HF3-B | BS105-3 | B72C6-6F | TH3-21-002 |
| FD45-1101-08-10 | B4-HP26 | HNV-12-NPT-F5 | 804501106 | BH4-60 | 4HF4-B | BS105-4 | B72C8-8F | TH4-26-002 |
| FD45-1101-12-12 | B6-HP31 | HNV-34-NPT-F5 | 804501108 | BH6-60 | 6HF6-B | BS105-6 | B72C12-12F | TH6-31-002 |
| FD45-1101-16-16 | B8-HP36 | HNV-1-NPT-F5 | 804501110 | BH8-60 | 8HF8-B | BS105-8 | B72C16-16F | TH8-36-002 |
| FD45-1101-20-20 | B10-H41 | - | - | - | 10HF10-B | - | - | - |
| FD45-1168-08-06 | 3-K8 | - | - | H3-63-T8 | H3OF4 | S101-3-8 | 72N6-8EF | - |
| FD45-1168-16-16 | 8-KP16 | HNV-1-1SAE-M | - | H8-63-T16 | H8OF8 | S101-8-16 | 72N16-16EF | - |
| FD45-1169-08-06 | 3-H8 | - | - | H3-62-T8 | 3HOF4 | S105-3-8 | 72C6-8EF | - |
| FD45-1169-16-16 | 8-HP16 | HNV-1-1SAE-F | - | H8-62-T16 | 8HOF8 | S105-8-16 | 72C16-16EF | - |
| FD45-1414-06-04 | 2-H6 | HNV-14-38SAE-F | 800604202 | H2-62-T6 | 2HOF3 | S105-2-6 | 72C4-6EF | - |
| FD45-1415-06-04 | 2-K6 | HNV-14-38SAE-M | 800604201 | H2-63-T6 | H2OF3 | S101-2-6 | 72N4-6EF | - |
| FD48-1001-04-04 | - | - | - | SIM-251-4FP | - | SH25-2P | - | - |
| FD48-1002-04-04 | - | - | - | SIM-252-4FP | - | SH21-2P | - | - |
| FD49-1001-06-06 | 10FFS37 | 2FFN38-NPT-F | 801301006 | FF-371-6FP | 3HTF3 | - | 74C6-6F | EC3-21 |
| FD49-1001-08-06 | 10FFS50 | 2FFN38-12-NPT-F | 801301008 | FF-371-8FP | 3HTF4 | - | 74C6-8F | EC3-26 |
| FD49-1002-06-06 | 10FFP37 | 2FFN38-NPT-M | 801301005 | FF-372-6FP | HT3F3 | - | 74N6-6F | EP3-21 |
| FD49-1002-08-06 | 10FFP50 | 2FFN38-12-NPT-M | 801301007 | FF-372-8FP | HT3F4 | - | 74N6-8F | EP3-26 |

| EATON | HANSEN | FASTER | STUCCHI | PARKER | PERFECTING | SAFEWAY | SNAP-TITE | TOMCO |
|-----------------|-----------------|----------------|---------------------|-------------|--------------|----------|-----------------|--------------|
| FD49-1004-06-06 | 10FFP56UN | - | 801304005 | - | HT30F3 | - | 74N6-6EF | - |
| FD49-1004-08-06 | 10FFP75UN | 2FFN38-12SAE-M | 801304007 | FF-372-8FO | HT30F4 | - | 74N6-8EF | EP3-8 |
| FD49-1005-08-06 | 10FFS75UN | 2FFN38-12SAE-F | 801304008 | FF-371-8FO | 3HTOF4 | - | 74C6-8EF | EC3-8 |
| FD49-1014-06-06 | 10FFS56ORM | - | 803704004 | - | - | - | 74C6-6EM | - |
| FD49-1014-08-06 | 10FFS75ORM | 2FFN38-1/12S-F | 803704006 | - | 3HTOM4 | - | 74C6-8EM | - |
| FD49-1042-06 | PDC10FF/SDC10FF | TM-F38/TF-F38 | 815100002/815100003 | NR-50/NR-37 | 3HTDP/HT3DC | - | 74PCC-6/74PNC-6 | FP3DC/5606DC |
| FD49-1057-06-06 | 10FFP56ORM | - | 801304037 | - | - | - | 74N6-6EM | - |
| FD49-1057-08-06 | 10FFP75ORM | 2FFN38-1/12S-M | 801304033 | - | HT3OM4 | - | 74N6-8EM | - |
| 5100-10B | - | - | - | 6100-08 | - | - | - | - |
| 5100-12B | - | - | - | 6100-12 | - | - | - | - |
| 5100-16B | - | - | - | 6100-16 | - | - | - | - |
| 5100-20B | - | - | - | 6100-20 | - | - | - | - |
| 5100-22-24S | - | - | - | 6107-24 | W12-BMF | - | 78F-24 | - |
| 5100-24B | - | - | - | 6100-24 | - | - | - | - |
| 5100-4B | - | - | - | - | - | - | - | - |
| 5100-6B | - | - | - | - | - | - | - | - |
| 5100-8B | - | - | - | - | - | - | - | - |
| 5100-S2-10B | - | - | - | 6105-08 | W6F4-B | - | - | 51P-8 |
| 5100-S2-12B | 96-P31 | FB12/34NPT-M5 | 100610112 | 6105-12 | W6F6-B | S511-6 | B78N12-12F | 51P-12 |
| 5100-S2-16B | 96-P36 | FB16/11NPT-M5 | 100610116 | 6105-16 | W8F8-B | S511-8 | B78N16-16F | 51P-16 |
| 5100-S2-20B | 96-P41 | FB20/114NPT-M5 | 100610120 | 6105-20 | W10F10-B | S511W-10 | B78N20-20F | 51P-20 |
| 5100-S2-24B | - | FB24*112NPT-M5 | 100610124 | 6105-24 | W12F12-B | - | B78N24-24F | - |
| 5100-S2-4B | - | - | - | - | - | - | - | - |
| 5100-S2-6B | - | - | - | - | - | - | - | - |
| 5100-S2-8B | - | - | - | - | - | - | - | - |
| 5100-S4-10B | - | - | - | 6115-08 | W6F4-B-BMF | - | - | 51PF-8 |
| 5100-S4-12B | - | - | - | 6115-12 | W6F6-B-BMF | - | B78N12-12FWF | 51PF-12 |
| 5100-S4-16B | - | - | - | 6115-16 | W8F8-B-BMF | - | B78N16-16FWF | 51PF-16 |
| 5100-S4-20B | - | - | - | 6115-20 | W10F10-B-BMF | - | B78N20-20FWF | 51PF-20 |
| 5100-S4-24B | - | - | - | 6115-24 | W12F12-B-BMF | - | B78N24-24FWF | - |
| 5100-S4-4B | - | - | - | - | - | - | - | - |
| 5100-S4-6B | - | - | - | - | - | - | - | - |
| 5100-S4-8B | - | - | - | - | - | - | - | - |
| 5100-S5-10B | - | - | - | 6125-08 | 6WF4-B | - | - | 51W-8 |
| 5100-S5-12B | 96-S31 | FB12/34NPT-F5 | 100610012 | 6125-12 | 6WF6-B | S515W-6 | B78C12-12F | 51W-12 |
| 5100-S5-16B | 96-S36 | FB16/11NPT-F5 | 100610016 | 6125-16 | 8WF8-B | S515W-8 | B78C16-16F | 51W-16 |
| 5100-S5-20B | 96-S41 | FB20/114NPT-F5 | 100610020 | 6125-20 | 10WF10-B | S515W-10 | B78C20-20F | 51W-20 |
| 5100-S5-24B | - | FB24/112NPT-F5 | 100610024 | 6125-24 | 12WF12-B | - | B78C24-24F | - |
| 5100-S5-4B | - | - | - | - | - | - | - | - |
| 5100-S5-6B | - | - | - | - | - | - | - | - |

| EATON | HANSEN | FASTER | STUCCHI | PARKER | PERFECTING | SAFeway | SNAP-TITE | TOMCO |
|-------------|------------|----------|-----------|---------|-------------|----------|-------------|---------|
| 5100-S5-8B | - | - | - | - | - | - | - | - |
| 5100-S7-12 | PDC-96-075 | TFFB12-5 | 200610112 | 6108-08 | W6DC-B | - | 78DC-12 | 51DC-12 |
| 5100-S7-16 | PDC-96-100 | TFFB16-5 | 200610116 | 6108-16 | W8DC-B | - | 78DC-16 | 51DC-16 |
| 5100-S7-20 | PDC-96-125 | TFFB20-5 | 200610120 | 6108-20 | W10DC-B | - | 78DC-20 | 51DC-20 |
| 5100-S7-24 | - | TFFB24-5 | 200610124 | 6108-24 | W12DC-B | - | 78DC-24 | - |
| 5100-S7-5 | - | - | - | - | - | - | - | - |
| 5100-S7-8 | - | - | - | - | - | - | - | - |
| 5100-S9-12 | SDC-96-075 | TMFB12-5 | 200610012 | 6109-08 | 6WDP-B | - | 78DP-12 | 51DP-12 |
| 5100-S9-16 | SDC-96-100 | TMFB16-5 | 200610016 | 6109-16 | 8WDP-B | - | 78DP-16 | 51DP-16 |
| 5100-S9-20 | SDC-96-125 | TMFB20-5 | 200610020 | 6109-20 | 10WDP-B | - | 78DP-20 | 51DP-20 |
| 5100-S9-24 | - | TMFB24-5 | 200610024 | 6109-24 | 12WDP-B | - | 78DP-24 | - |
| 5100-S9-5 | - | - | - | - | - | - | - | - |
| 5100-S9-8 | - | - | - | - | - | - | - | - |
| 5101-10B | - | - | - | 6120-08 | - | - | - | - |
| 5101-12B | - | - | - | 6120-12 | - | S51W-6 | - | - |
| 5101-16B | - | - | - | 6120-16 | - | S51W-8 | - | - |
| 5101-20B | - | - | - | 6120-20 | - | S51W-10 | - | - |
| 5101-24B | - | - | - | 6120-24 | - | - | - | - |
| 5101-4B | - | - | - | - | - | - | - | - |
| 5101-6B | - | - | - | - | - | - | - | - |
| 5101-8B | - | - | - | - | - | - | - | - |
| 5110-10B | - | - | - | 6110-08 | - | - | - | - |
| 5110-12B | - | - | - | 6110-12 | - | - | - | - |
| 5110-16B | - | - | - | 6110-16 | - | - | - | - |
| 5110-20B | - | - | - | 6100-20 | - | - | - | - |
| 5110-24B | - | - | - | 6110-24 | - | - | - | - |
| 5110-4B | - | - | - | - | - | - | - | - |
| 5110-6B | - | - | - | - | - | - | - | - |
| 5110-8B | - | - | - | - | - | - | - | - |
| 5110-S5-10B | - | - | - | 6135-08 | 6WF4-B-HN | - | - | 51H-8 |
| 5110-S5-12B | - | - | - | 6135-12 | 6WF6-B-HN | S515H-6 | B78HC12-12F | 51H-12 |
| 5110-S5-16B | - | - | - | 6135-16 | 8WF8-B-HN | S515H-8 | B78HC16-16F | 51H-16 |
| 5110-S5-20B | - | - | - | 6135-20 | 10WF10-B-HN | S515H-10 | B78HC20-20F | 51H-20 |
| 5110-S5-24B | - | - | - | 6135-24 | 12WF12-B-HN | - | B78HC24-24F | - |
| 5110-S5-4B | - | - | - | - | - | - | - | - |
| 5110-S5-6B | - | - | - | - | - | - | - | - |
| 5110-S5-8B | - | - | - | - | - | - | - | - |
| 5111-10B | - | - | - | 6130-08 | - | - | - | - |
| 5111-12B | - | - | - | 6130-12 | - | S51H-6 | - | - |
| 5111-16B | - | - | - | 6130-16 | - | S51H-8 | - | - |

| EATON | HANSEN | FASTER | STUCCHI | PARKER | PERFECTING | SAFEWAY | SNAP-TITE | TOMCO |
|-------------|-------------|----------------|-----------|------------|------------|-----------|------------|-----------|
| 5111-20B | - | - | - | 6130-20 | - | S51H-10 | - | - |
| 5111-24B | - | - | - | 6130-24 | - | - | - | - |
| 5111-4B | - | - | - | - | - | - | - | - |
| 5111-6B | - | - | - | - | - | - | - | - |
| 5111-8B | - | - | - | - | - | - | - | - |
| 5601-12-10S | - | - | - | 12/10/01 | 4KF6 | - | 61C8-12F | CA5604-31 |
| 5601-12-12S | HA-15241-00 | ANV-34-NPT-F | 800501006 | 12/12/01 | 6KF6 | S565-6 | 61C12-12F | CA5606-31 |
| 5601-16-16S | HA-15251-00 | ANV-1-NPT-F | 800501008 | 6601-16-16 | 8KF8 | S565-8 | 61C16-16F | CA5608-36 |
| 5601-2-4S | - | - | - | 2/4/01 | 2KF1 | - | - | - |
| 5601-4-4S | HA-15211-00 | ANV-14-NPT-F | 800501000 | 4/4/01 | 2KF2 | S565-2 | 61C4-4F | CA5602-16 |
| 5601-6-6S | HA-15221-00 | ANV-38-NPT-F | 800501002 | 6/6/01 | 3KF3 | S565-3 | 61C6-6F | CA5603-21 |
| 5601-8-10S | HA-15231-00 | NV-12-NPT-F | 800501004 | 8/10/01 | 4KF4 | S565-4 | 61C8-8F | CA5604-26 |
| 5602-12-10S | - | - | - | 12/10/02 | K4F6 | - | 61N8-12F | PA5604-31 |
| 5602-12-12S | HA-15242-00 | ANV-34-NPT-M | 800501007 | 12/12/02 | K6F6 | S561-6 | 61N12-12F | PA5606-31 |
| 5602-16-16S | HA-15252-00 | ANV-1-NPT-M | 800501009 | 6602-16-16 | K8F8 | S561-8 | 61N16-16F | PA5608-36 |
| 5602-2-4S | - | - | - | 2/4/02 | K2F1 | - | - | - |
| 5602-4-4S | HA-15212-00 | ANV-14-NPT-M | 800501001 | 4/4/02 | K2F2 | S561-2 | 61N4-4F | PA5602-16 |
| 5602-6-6S | HA-15222-00 | ANV-38-NPT-M | 800501003 | 6/6/02 | K3F3 | S561-3 | 61N6-6F | PA5603-21 |
| 5602-8-10S | HA-15232-00 | NV-12-NPT-M | 800501005 | 8/10/02 | K4F4 | S561-4 | 61N8-8F | PA5604-26 |
| 5608-10-10S | - | NV-12-58SAE-F | - | 10/10/08 | 4KOF5 | S565-4-10 | 61C8-10EF | CA5604-10 |
| 5608-12-10S | - | - | - | 12/10/08 | - | - | - | - |
| 5608-12-12S | - | ANV-34-34SAE-F | - | 12/12/08 | 6KOF6 | S565-6-12 | 61C12-12EF | - |
| 5608-16-16S | - | ANV-1-1SAE-F | - | 6608-16-16 | 8KOF8 | S565-8-16 | 61C16-16EF | - |
| 5608-4-4S | - | - | - | - | - | - | - | - |
| 5608-6-6S | - | ANV-38-38SAE-F | - | 6/6/08 | 3KOF3 | S565-3-6 | - | - |
| 5608-8-10S | - | NV-12-12SAE-F | - | 8/10/08 | 4KOF4 | S565-4-8 | 61C8-8EF | CA5604-8 |
| 5610-10-10S | - | NV-12-58SAE-M | - | 10/10/10 | K4OF5 | S561-4-10 | 61N8-10EF | PA5604-10 |
| 5610-12-10S | - | - | - | 12/10/10 | - | - | - | - |
| 5610-12-12S | - | ANV-34-34SAE-M | - | 12/12/10 | K6OF6 | S561-6-12 | 61N12-12EF | - |
| 5610-16-16S | - | ANV-1-1SAE-M | - | 6610-16-16 | K8OF8 | S561-8-16 | 61N16-16EF | - |
| 5610-4-4S | - | - | - | - | - | - | - | - |
| 5610-6-6S | - | ANV-38-38SAE-M | - | 6/6/10 | K3OF3 | S561-3-6 | - | - |
| 5610-8-10S | - | NV-12-12SAE-M | - | 8/10/10 | K4OF4 | S561-4-8 | 61N8-8EF | PA5604-8 |
| 5657-10 | HP-15132-00 | TF-12-G | 815000005 | 5209-4M | K4DC | S59-4 | PDC-12 | 5604DC |
| 5657-12 | HP-15142-00 | TFA-34 | 815000017 | 6657-12M | K6DC | S59-6 | 61PDC-12 | 5606DC |
| 5657-16 | HP-15152-00 | TFA-1 | 815000019 | 6657-16M | K8DC | S59-8 | 61PDC-16 | 5608DC |
| 5657-4 | HP-15112-00 | TFA-14 | 815000013 | H1-66M | K2DC | S59-2 | 61PDC-4 | 5602DC |
| 5657-6 | HP-15122-00 | TFA-38 | 815000015 | TR-37 | K3DC | S59-3 | PDC-8 | 5603DC |
| 5659-10 | HP-15131-00 | TM-12L-G | 815000004 | 5205-4M | 4KDP | S54-4 | 61PDP-8 | 5604DP |
| 5659-12 | HP-15141-00 | TMA-34 | 815000016 | 6659-12M | 6KDP | S54-6 | 61PDP-12 | 5606DP |

COMPETITOR
CROSS REFERENCE

COMPETITOR CROSS REFERENCE

| EATON | HANSEN | FASTER | STUCCCHI | PARKER | PERFECTING | SAFEWAY | SNAP-TITE | TOMCO |
|-----------------|-------------|-----------------|-----------|----------------|-------------|--------------|------------|--------|
| 5659-16 | HP-15151-00 | TMA-1 | 815000018 | 6659-16M | 8KDP | S54-8 | 61PDP-16 | 5608DP |
| 5659-4 | HP-15111-00 | TMA-14 | 915000012 | H1-65M | 2KDP | S54-2 | 61PDP-4 | 5602DP |
| 5659-6 | HP-15121-00 | TMA-38 | 815000014 | TR-37 | 3KDP | S54-3 | PDP-8 | 5603DP |
| FD69-1001-06-08 | - | - | - | - | 4EAF3 | - | 56C8-6F | - |
| FD69-1001-08-08 | - | - | - | WB-501-8FP | 4EAF4 | - | 56C8-8F | - |
| FD69-1002-06-08 | - | - | - | - | EA4F3 | - | 56N8-6F | - |
| FD69-1002-08-08 | - | - | - | WB-502-8FP | EA4F4 | - | 56N8-8F | - |
| FD69-1011-08-08 | - | - | - | - | - | - | - | - |
| FD69-1012-08-08 | - | - | - | - | - | - | - | - |
| FD72-1001-08-10 | - | - | 800401004 | 8250-4 | 4AGF4-PV-PS | S45-4P | 61DC8-8F | C4-26 |
| FD76-1002-08-10 | - | - | 800501005 | 8010-4P | AG4F4-PV | S71-4P | 63N8-8F | P4-26 |
| FD76-1010-08-10 | - | - | - | 8010-15P | AG4OF4-PV | S71-15P | 63N8-8EF | P4-8 |
| FD89-1001-04-04 | 6FFS25 | 2FFH14-NPT-F | 800801000 | FEM-251-4FP-NL | 2HTF2 | FFE495-2 | 74C4-4F | EC2-16 |
| FD89-1001-06-06 | 10FFS37 | 2FFN38-NPT-F | 800801004 | FEM-371-6FP-NL | 3HTF3 | - | 74C6-6F | EC3-21 |
| FD89-1001-08-06 | 10FFS50 | 2FFN38-12-NPT-F | 800801002 | - | 3HTF4 | - | 74C6-8F | EC3-26 |
| FD89-1001-08-08 | 12FFS50 | 2FFH12-NPT-F | 800801006 | FEM-501-8FP-NL | 4HTF4 | FFE495-4 | 74C8-8F | EC4-26 |
| FD89-1001-12-08 | 12FFS75 | 2FFH12-34-NPT-F | 800801008 | - | 4HTF6 | FFE495-4-3/4 | 74C8-12F | EC4-31 |
| FD89-1001-12-12 | 16FFS75 | 2FFI58-34N-F | 800801010 | - | 5HTF6 | - | 74C10-12F | - |
| FD89-1001-16-16 | 19FFS100 | 2FFI34-1-NPT-F | 800801012 | - | 6HTF8 | FFE495-6-1 | 74C12-16F | - |
| FD89-1001-20-20 | 25FFS125 | - | 800801014 | - | 8HTF10 | FFE495-8-114 | 74C16-20F | - |
| FD89-1001-24-24 | - | 2FSI112-NPT-F | - | - | - | - | - | - |
| FD89-1001-32-32 | - | 2FSI2-NPT-F | - | - | - | - | - | - |
| FD89-1002-04-04 | 6FFP25 | 2FH14-NPT-M | 800801001 | FEM-252-4FP | HT2F2 | FFE491-2 | 74N4-4F | EP2-16 |
| FD89-1002-06-06 | 10FFP37 | 2FFN38-NPT-M | 800801005 | FEM-372-6FP | HT3F3 | - | 74N6-6F | EP3-21 |
| FD89-1002-08-06 | 10FFP50 | 2FFN38-12NPT-M | 800801003 | - | HT3F4 | - | 74N6-8F | EP3-26 |
| FD89-1002-08-08 | 12FFP50 | 2FH12-NPT-M | 800801007 | FEM-502-8FP | HT4F4 | FFE491-4 | 74N8-8F | EP4-26 |
| FD89-1002-12-08 | 12FFP75 | 2FFH12-34-NPT-M | 800801009 | - | HT4F6 | FFE491-4-3/4 | 74N8-12F | EP4-31 |
| FD89-1002-12-12 | 16FFP75 | FFI58-34N-M | 800801011 | - | HT5F6 | - | 74N10-12F | - |
| FD89-1002-16-16 | 19FFP100 | FFI34-1-NPT-M | 800801013 | - | HT6F8 | FFE491-6-1 | 74N12-16F | - |
| FD89-1002-20-20 | 25FFP125 | - | 800801015 | - | HT8F10 | FFE491-8-114 | 74N16-20F | - |
| FD89-1002-24-24 | - | FFI112-NPT-M | - | - | - | - | - | - |
| FD89-1002-32-32 | - | FFI2-NPT-M | - | - | - | - | - | - |
| FD89-1004-06-04 | 6FFP56UN | 2FFH14-38SAE-M | 800804001 | FEM-252-6FO | - | - | 74N4-6EF | - |
| FD89-1004-08-06 | 10FFP75UN | 2FFN38-12SAE-M | 800804003 | FEM-372-8FO | HT3OF4 | - | 74N6-8EF | EP3-8 |
| FD89-1004-10-06 | 10FFP87UN | 2FFN38-58SAE-M | 800804005 | - | - | - | 74N6-10EF | - |
| FD89-1004-10-08 | 12FFP87UN | 2FFH12-58SAE-M | 800804007 | FEM-502-10FO | HT4OF5 | FFE491-4-10 | 74N8-10EF | - |
| FD89-1004-12-08 | 12FFP106UN | 2FFH12-34SAE-M | 800804009 | FEM-502-12FO | HT4OF6 | FFE491-4-12 | 74N8-12EF | EP4-12 |
| FD89-1004-12-12 | 16FFP106UN | FFI58-34SAE-M | 800804011 | FEM-622-12FO | HT5OF6 | - | 74N10-12EF | - |
| FD89-1004-20-20 | 25FFP162UN | - | 800804015 | - | HT8OF10 | FFE491-8-20 | 74N16-20EF | - |
| FD89-1004-24-24 | - | - | - | - | - | - | - | - |

| EATON | HANSEN | FASTER | STUCCHI | PARKER | PERFECTING | SAFEWAY | SNAP-TITE | TOMCO |
|-----------------|------------|-----------------|-----------|-----------------|------------|-------------|------------|--------|
| FD89-1004-32-32 | - | - | - | - | - | - | - | - |
| FD89-1005-06-04 | 6FFS56UN | 2FFI14-38SAE-F | 800804000 | FEM-251-6FO-NL | - | - | 74C4-6EF | - |
| FD89-1005-08-06 | 10FFS75UN | 2FFN38-12SAE-F | 800804002 | FEM-371-8FO-NL | 3HTOF4 | - | 74C6-8EF | EC3-8 |
| FD89-1005-10-06 | 10FFS87UN | 2FFN38-58SAE-F | 800804004 | - | - | - | 74C6-10EF | - |
| FD89-1005-10-08 | 12FFS87UN | 2FFI12-58SAE-F | 800804006 | FEM-501-10FO-NL | 4HTOF5 | FFE495-4-10 | 74C8-10EF | - |
| FD89-1005-12-08 | 12FFS106UN | 2FFI12-34SAE-F | 800804008 | FEM-501-12FO-NL | 4HTOF6 | FFE495-4-12 | 74C8-12EF | EC4-12 |
| FD89-1005-12-12 | 16FFS106UN | 2FFI58-34SAE-F | 800804010 | FEM-621-12FO-NL | 5HTOF6 | - | 74C10-12EF | - |
| FD89-1005-16-16 | 19FFS131UN | 2FFI34-1SAE-F | 800804012 | - | 6HTOF8 | FFE495-6-16 | 74C12-16EF | - |
| FD89-1005-20-20 | 25FFS162UN | - | 800804014 | - | 8HTOF10 | FFE495-8-20 | 74C16-20EF | - |
| FD89-1005-24-24 | - | - | - | - | - | - | - | - |
| FD89-1005-32-32 | - | - | - | - | - | - | - | - |
| FD89-1006-04-04 | 6FFS25BS | 2FFI14-GAS-F | 800800000 | - | 2HTBF2 | - | 74C4-4RP | - |
| FD89-1006-06-06 | 10FFS37BS | 2FFN38-GAS-F | 800800004 | - | 3HTBF3 | - | 74C6-6RP | - |
| FD89-1006-08-06 | 10FFS50BS | 2FFN38-12-GAS-F | 800800002 | - | 3HTBF4 | - | 74C6-8RP | - |
| FD89-1006-08-08 | 12FFS50BS | 2FFI12-GAS-F | 800800006 | - | 4HTBF4 | - | 74C8-8RP | - |
| FD89-1006-12-08 | 12FFS75BS | 2FFI12-34-GAS-F | 800800008 | - | 4HTBF6 | - | 74C8-12RP | - |
| FD89-1006-12-12 | 16FFS75BS | 2FFI58-34-GAS-F | 800800010 | - | 5HTBF6 | - | 74C10-12RP | - |
| FD89-1006-16-16 | 19FFS100BS | 2FFI34-1-GAS-F | 800800012 | - | 6HTBF8 | - | 74C12-16RP | - |
| FD89-1006-20-20 | 25FFS125BS | - | 800800014 | - | 8HTBF10 | - | 74C16-20RP | - |
| FD89-1006-24-24 | - | 2FSI112-GAS-F | 800800016 | - | - | - | - | - |
| FD89-1006-32-32 | - | 2FSI2-GAS-F | 800800018 | - | - | - | - | - |
| FD89-1007-04-04 | 6FFP25BS | 2FFI14-GAS-M | 800800001 | - | HT2BF2 | - | 74N4-4RP | - |
| FD89-1007-06-06 | 10FFP37BS | 2FFN38-GAS-M | 800800005 | - | HT3BF3 | - | 74N6-6RP | - |
| FD89-1007-08-06 | 10FFP50BS | 2FFN38-12-GAS-M | 800800003 | - | HT3BF4 | - | 74N6-8RP | - |
| FD89-1007-08-08 | 12FFP50BS | 2FFI12-GAS-M | 800800007 | - | HT4BF4 | - | 74N8-8RP | - |
| FD89-1007-12-08 | 12FFP75BS | 2FFA12-34-GAS-M | 800800009 | - | HT4BF6 | - | 74N8-12RP | - |
| FD89-1007-12-12 | 16FFP75BS | FFI58-34GAS-M | 800800011 | - | HT5BF6 | - | 74N10-12RP | - |
| FD89-1007-16-16 | 19FFP100BS | FFI34-1-GAS-M | 800800013 | - | HT6BF8 | - | 74N12-16RP | - |
| FD89-1007-20-20 | 25FFP125BS | FFI1-114-G-M | 800800015 | - | HT8BF10 | - | 74N16-20RP | - |
| FD89-1007-24-24 | - | FFI112-GAS-M | 801300025 | - | - | - | - | - |
| FD89-1007-32-32 | - | FFI2-GAS-M | 800800019 | - | - | - | - | - |
| FD89-1008-04 | PDC8FF | TF-2FI14 | 815100001 | FR-25 | - | - | 74PNC-4 | - |
| FD89-1008-06-06 | PDC10FF | TF-F38 | 815100003 | NR-50 | HT3DC | - | 74PNC-6 | FP3DC |
| FD89-1008-08-06 | PDC10FF | TF-F38 | 815100005 | NR-50 | HT3DC | - | 74PNC-6 | FP3DC |
| FD89-1008-08-08 | PDC12FF | TF-2FI12 | 815100007 | FR-501 | HT4DC | - | 74PNC-8 | - |
| FD89-1008-12 | PDC16FF | TF-2FI58 | 815100011 | - | HT5DC | - | 74PNC-10 | - |
| FD89-1008-12-08 | PDC12FF | TF-2FI12 | 815100009 | FR-501 | HT4DC | - | 74PNC-8 | - |
| FD89-1008-16 | PDC19FF | TF-2FI34 | 815100013 | FR-751 | HT6DC | - | 74PNC-12 | - |
| FD89-1008-20 | PDC25FF | TF-2FI1 | 815100015 | FR-1001 | HT8DC | - | 74PNC-16 | - |
| FD89-1008-24 | - | TF-2FI112-S | 815100017 | - | - | - | - | - |

| EATON | HANSEN | FASTER | STUCCHI | PARKER | PERFECTING | SAFESWAY | SNAP-TITE | TOMCO |
|-----------------|----------|------------------|-----------|---------|------------|----------|-----------|------------|
| FD89-1008-32 | - | TF-2FI2-S | 815100019 | - | - | - | - | - |
| FD89-1009-04 | SDC6FF | TM-2FI14 | 815100000 | FR-25 | - | - | 74PCC-4 | - |
| FD89-1009-06 | SDC10FF | TM-F38 | 815100002 | NR-37 | 3HTDP | - | 74PCC-6 | 560DSC |
| FD89-1009-08-08 | SDC12FF | TM-2FI12 | 815100004 | FER-502 | 4HTDP | - | 74PCC-8 | - |
| FD89-1009-12 | SDC16FF | TM-2FI58 | 815100008 | - | 5HTDP | - | 74PCC-10 | - |
| FD89-1009-12-08 | SDC12FF | TM-2FI12 | 815100006 | FER-502 | 4HTDP | - | 74PCC-8 | - |
| FD89-1009-16 | SDC19FF | TM-2FI34 | 815100010 | FER-752 | 6HTDP | - | 74PCC-12 | - |
| FD89-1009-20 | SDC25FF | TM-2FI1 | 815100012 | - | 8HTDP | - | 74PCC-16 | - |
| FD89-1009-24 | - | TM-2FI112-S | 815100014 | - | - | - | - | - |
| FD89-1009-32 | - | TM-2FI2-S | 815100016 | - | - | - | - | - |
| FD89-2001-04-04 | - | 2FFI14-NPT-F2 | 802401100 | - | - | - | - | - |
| FD89-2001-06-06 | 3DBS-37F | 2FFN38-NPT-F2 | 802401102 | - | 3HTF3-SS | SF495-3 | - | FC3-21-316 |
| FD89-2001-08-08 | - | 2FFI12-NPT-F2 | 802401106 | - | 4HTF4-SS | - | - | - |
| FD89-2001-12-10 | - | 2FFI58-34N-F2 | 802401110 | - | 5HTF6-SS | - | - | - |
| FD89-2001-16-12 | - | 2FFI34-1N-F2 | 802401112 | - | 6HTF8-SS | - | - | - |
| FD89-2001-20-16 | - | - | 802401114 | - | 8HTF10-SS | - | - | - |
| FD89-2002-04-04 | - | FFI14-NPT-M2 | 802401101 | - | - | - | - | - |
| FD89-2002-06-06 | 3DBP-37F | FFN38-NPT-M2-U | 802401103 | - | HT3F3-SS | SF491-3 | - | FP3-21-316 |
| FD89-2002-08-08 | - | FFI12-NPT-M2 | 802401107 | - | HT4F4-SS | - | - | - |
| FD89-2002-12-10 | - | FFI58-34N-M2 | 802401111 | - | HT5F6-SS | - | - | - |
| FD89-2002-16-12 | - | FFI34-1N-M2 | 802401113 | - | HT6F8-SS | - | - | - |
| FD89-2002-20-16 | - | - | 802401115 | - | HT8F10-SS | - | - | - |
| FD90-1004-03-04 | - | - | - | PD331-6 | - | - | - | - |
| FD90-1004-04-04 | - | - | - | PD341-6 | - | - | - | - |
| FD90-1004-05-04 | - | - | - | PD351-6 | - | - | - | - |
| FD90-1004-06-04 | - | - | - | PD361-6 | - | - | - | - |
| FD90-1012-02-04 | - | DF-04-1/18NPT-M | - | PD323 | PD1M1 | - | - | KP1-10 |
| FD90-1012-04-04 | - | DF-04-1/14NPT-M | - | PD343 | PD1M2 | - | - | KP1-15 |
| FD90-1021-02-04 | - | DF-04-18NPT-F | - | PD222 | 1PDF1 | - | - | KC1-11 |
| FD90-1021-04-04 | - | DF-04-14NPT-F | - | PD242 | 1PDF2 | - | - | KC1-16 |
| FD90-1034-02-04 | - | DF-04-18NPT-M | - | PD322 | PD1F1 | - | - | KP1-11 |
| FD90-1034-04-04 | - | DF-04-14NPT-M | - | PD342 | PD1F2 | - | - | KP1-16 |
| FD90-1035-02-04 | - | - | - | PD322-6 | - | - | - | - |
| FD90-1035-04-04 | - | - | - | PD342-6 | - | - | - | - |
| FD90-1040-04 | - | TDF-04 | - | PD6-285 | - | - | - | DK1C |
| FD90-1041-04-04 | - | DF-04-14SAE-F | - | PD240 | - | - | - | - |
| FD90-1044-03-04 | - | DF-04-1/316SAE-M | - | PD331 | - | - | - | - |
| FD90-1044-04-04 | - | DF-04-1/14SAE-M | - | PD341 | PD1OM2 | - | - | KP1-4 |
| FD90-1044-05-04 | - | DF-04-1/516SAE-M | - | PD351 | - | - | - | - |
| FD90-1044-06-04 | - | DF-04-1/38SAE-M | - | PD361 | PD1OM3 | - | - | KP1-6 |

| EATON | HANSEN | FASTER | STUCCHI | PARKER | PERFECTING | SAFEWAY | SNAP-TITE | TOMCO |
|-----------------|------------|------------------|-----------|---------|------------|---------|-----------|-------|
| FD90-1045-02-04 | - | - | - | PD323-6 | - | - | - | - |
| FD90-1045-04-04 | - | - | - | PD343-6 | - | - | - | - |
| FD90-1046-06-04 | - | DF-04-21/1415-M | - | - | - | - | - | - |
| FD90-1047-06-04 | - | - | - | - | - | - | - | - |
| FD90-1061-04-04 | - | DF-04-35/14SAE-M | - | PD348TL | - | - | - | - |
| FD90-1061-06-04 | - | DF-04-35/38SAE-M | - | PD368TL | - | - | - | - |
| FD90-1061-08-04 | - | DF-04-35/12SAE-M | - | PD388TL | - | - | - | - |
| FD90-1090-10-04 | - | - | - | PD357 | - | - | - | - |
| FD90-1206-04-04 | - | DF-04-12/14SAE-M | - | PD346 | - | - | - | - |
| FD99-1001-04-04 | 6FFS25 | 2FFI14-NPT-F | 801301004 | - | - | - | - | - |
| FD99-1001-06-06 | 10FFS37 | 2FFN38-NPT-F | 801301006 | - | - | - | - | - |
| FD99-1001-08-06 | 10FFS50 | 2FFN38-12-NPT-F | 801301008 | - | - | - | - | - |
| FD99-1001-08-08 | 12FFS50 | 2FFI12-NPT-F | 801301010 | - | - | - | - | - |
| FD99-1001-12-08 | 12FFS75 | 2FFI12-34-NPT-F | 801301012 | - | - | - | - | - |
| FD99-1001-12-10 | 16FFS75 | 2FFI58-34-NPT-F | 801301014 | - | - | - | - | - |
| FD99-1001-12-12 | 19FFS75 | 2FFI34-NPT-F | 801301030 | - | - | - | - | - |
| FD99-1001-16-12 | 19FFS100 | 2FFI34-1-NPT-F | 801301000 | - | - | - | - | - |
| FD99-1001-16-16 | 25FFS100 | 2FFI1-NPT-F | 801301028 | - | - | - | - | - |
| FD99-1001-20-16 | 25FFS125 | - | - | - | - | - | - | - |
| FD99-1002-04-04 | 6FFP25 | 2FFI14-NPT-M | 800801001 | - | - | - | - | - |
| FD99-1002-06-06 | 10FFP37 | FFN38-NPT-MU | 801301005 | - | - | - | - | - |
| FD99-1002-08-06 | 10FFP50 | FFN38-12-NPT-MIU | 801301007 | - | - | - | - | - |
| FD99-1002-08-08 | 12FFP50 | FFI12-NPT-M | 801301009 | - | - | - | - | - |
| FD99-1002-12-08 | 12FFP75 | FFN12-34-NPT-M | 801301011 | - | - | - | - | - |
| FD99-1002-12-10 | 16FFP75 | FFI58-34-NPT-M | 801301013 | - | - | - | - | - |
| FD99-1002-12-12 | 19FFP75 | FFI34-NPT-M | 801301031 | - | - | - | - | - |
| FD99-1002-16-12 | 19FFP100 | FFI34-1-NPT-M | 801301001 | - | - | - | - | - |
| FD99-1002-16-16 | 25FFP100 | FFI1-NPT-M | 801301029 | - | - | - | - | - |
| FD99-1002-20-16 | 25FFP125 | - | - | - | - | - | - | - |
| FD99-1004-06-04 | 6FFS56UN | 2FFI14-38-SAE-F | 801304004 | - | - | - | - | - |
| FD99-1004-06-06 | 10FFS56UN | 2FFN38-SAE-F | 801304006 | - | - | - | - | - |
| FD99-1004-08-06 | 10FFS75UN | 2FFN38-12-SAE-F | 801304008 | - | - | - | - | - |
| FD99-1004-08-08 | 12FFS75UN | - | 803304004 | - | - | - | - | - |
| FD99-1004-10-06 | 10FFS87UN | 2FFN38-58-SAE-F | 801304030 | - | - | - | - | - |
| FD99-1004-10-08 | 12FFS87UN | 2FFI12-58-SAE-F | 801304024 | - | - | - | - | - |
| FD99-1004-12-08 | 12FFS106UN | 2FFI12-34-SAE-F | 801304010 | - | - | - | - | - |
| FD99-1004-12-10 | 16FFS106UN | 2FFI58-34-SAE-F | 801304012 | - | - | - | - | - |
| FD99-1004-12-12 | 19FFS106UN | 2FFI34-SAE-F | 801304028 | - | - | - | - | - |
| FD99-1004-16-12 | 19FFS131UN | 2FFI34-1-SAE-F | 801304000 | - | - | - | - | - |
| FD99-1004-16-16 | - | 2FFI1-1-SAE-F | 801304038 | - | - | - | - | - |

COMPETITOR
CROSS REFERENCE

| EATON | HANSEN | FASTER | STUCCCHI | PARKER | PERFECTING | SAFEWAY | SNAP-TITE | TOMCO |
|-----------------|-------------|-----------------|-----------|--------|------------|---------|------------|-------|
| FD99-1004-20-16 | 25FFS162UN | - | - | - | - | - | - | - |
| FD99-1005-06-04 | 6FFP56UN | 2FF114-38-SAE-M | 800804001 | - | - | - | - | - |
| FD99-1005-06-06 | 10FFP56UN | 2FFN38-38-SAE-M | 801304005 | - | - | - | - | - |
| FD99-1005-08-06 | 10FFP75UN | 2FFN38-12-SAE-M | 801304007 | - | - | - | - | - |
| FD99-1005-08-08 | 12FFP75UN | 2FF112-SAE-M | 801304035 | - | - | - | - | - |
| FD99-1005-10-06 | 10FFP87UN | 2FFN38-58-SAE-M | 801304031 | - | - | - | - | - |
| FD99-1005-10-08 | 12FFP87UN | 2FF112-58-SAE-M | 801304025 | - | - | - | - | - |
| FD99-1005-12-08 | 12FFP106UN | 2FF112-34-SAE-M | 801304009 | - | - | - | - | - |
| FD99-1005-12-10 | 16FFP106UN | 2FF158-34-SAE-M | 801304011 | - | - | - | - | - |
| FD99-1005-12-12 | 19FFP106UN | 2FF134-SAE-M | 801304029 | - | - | - | - | - |
| FD99-1005-16-12 | 19FFP131UN | 2FF134-1-SAE-M | 801304001 | - | - | - | - | - |
| FD99-1005-16-16 | - | 2FF11-SAE-M | 801304039 | - | - | - | - | - |
| FD99-1005-20-16 | 25FFP162UN | - | 8- | - | - | - | - | - |
| G5622-12-12 | HA-15042-00 | ANV-34-GAS-F | - | - | 6KBF6 | - | 61C12-12RP | - |
| G5622-16-16 | HA-15052-00 | ANV-1-GAS-F | - | - | 8KBF8 | - | 61C16-16RP | - |
| G5622-4-4 | HA-15012-00 | ANV-14-GAS-F | - | - | 2KBF2 | - | 61C4-4RP | - |
| G5622-6-6 | HA-15022-00 | ANV-38-GAS-F | - | - | 3KBF3 | - | 61C6-6RP | - |
| G5622-8-10 | HA-15032-00 | NV-12-GAS-F | - | - | 4KBF4 | - | 61C8-8RP | - |
| G5623-12-12 | HA-15041-00 | ANV-34-GAS-M | - | - | K6BF6 | - | 61N12-12RP | - |
| G5623-16-16 | HA-15051-00 | ANV-1-GAS-M | - | - | K8BF8 | - | 61N16-16RP | - |
| G5623-4-4 | HA-15011-00 | ANV-14-GAS-M | - | - | K2BF2 | - | 61N4-4RP | - |
| G5623-6-6 | HA-15021-00 | ANV-38-GAS-M | - | - | K3BF3 | - | 61N6-6RP | - |
| G5623-8-10 | HA-15031-00 | NV-12-GAS-M | - | - | K4BF4 | - | 61N8-8RP | - |

Notes

COMPETITOR
CROSS REFERENCE

Eaton
Hydraulics Group USA
14615 Lone Oak Road
Eden Prairie, MN 55344
USA
Tel: 952-937-9800
Fax: 952-294-7722
www.eaton.com/hydraulics

Eaton
Hydraulics Group Europe
Route de la Longeraie 7
1110 Morges
Switzerland
Tel: +41 (0) 21 811 4600
Fax: +41 (0) 21 811 4601

Eaton
Hydraulics Group Asia Pacific
Eaton Building
4th Floor, No. 3 Lane 280 Linhong Rd.
Changning District
Shanghai 200335
China
Tel: (+86 21) 5200 0099
Fax: (+86 21) 5200 0400



Powering Business Worldwide

© 2010 Eaton Corporation
All Rights Reserved
Printed in USA
Document No. E-MEQD-MC001-E2
June 2010